

仕 様 書

カトウ全油圧式オールテレールクレーン

KA-3000

キャリア : カトウ KA6350

クレーン部主要諸元

1. 名称	300ton吊りオールテレーンクレーン	
2. 型式	KA-3000	
3. クレーン性能		
最大定格総荷重		
・メインブーム	13.6 mブーム	※300.0t× 2.5m
	18.15mブーム	120.0t× 6.0m
	22.7 mブーム	120.0t× 6.0m
	31.8 mブーム	70.0t× 11.0m
	40.9 mブーム	60.0t× 12.0m
	45.5 mブーム	47.0t× 14.0m
	50.0 mブーム	35.0t× 18.0m
	最大作業半径時	8.9t× 46.0m
	※印は重荷重装置付	
・スーパーラフィングジブ (SLジブ)	40.9mブーム+2.0m+10.0mSL	24.0t× 22.0m
	40.9mブーム+2.0m+15.0mSL	12.0t× 36.0m
	45.5mブーム+2.0m+19.0mSL	12.0t× 32.0m
	45.5mブーム+2.0m+23.0mSL	12.0t× 26.0m
	40.9mブーム+2.0m+27.0mSL	12.0t× 22.0m
	45.5mブーム+2.0m+31.0mSL	9.0t× 28.0m
	最大作業半径時	1.8t× 66.0m
・ヘビーリフトジブ (HLジブ)	13.6mブーム+4.4m+13.0mHL	84.0t× 9.0m
	13.6mブーム+4.4m+22.0mHL	54.0t× 14.0m
	13.6mブーム+4.4m+31.0mHL	35.0t× 14.0m
	31.8mブーム+4.4m+40.0mHL	12.0t× 48.0m
	31.8mブーム+4.4m+47.0mHL	12.0t× 46.0m
	22.7mブーム+4.4m+54.0mHL	9.3t× 28.0m
	最大作業半径時	1.7t× 85.0m
最大地上揚程	ブーム	51.0m
	スーパーラフィングジブ	83.1m
	ヘビーリフトジブ	106.9m
巻上ロープ速度	主巻 (3層) 高速: 135m/min 低速: 80m/min 補巻 (3層) 高速: 135m/min 低速: 80m/min	
ブーム上げ時間	100s/−1.0° ~ 83°	
ブーム伸長速度	13.6m ~ 50.0m/220s	
旋回速度	高速: 1.4min ⁻¹ 低速: 0.7min ⁻¹	

4. 上部旋回体の装置及び構造

メインブーム	箱型5段油圧伸縮式 13.6m ~ 50.0m
スーパーラフィングジブ	2.0mベースブラケット+箱型4段油圧伸縮式 10.0m ~ 31.0m オフセット: 5° ~ 60°
ヘビーリフトジブ	4.4mベースブラケット+トラス式 13.0m ~ 54.0m オフセット: 10° ~ 60°
巻上装置	油圧モータ駆動、平歯車+遊星歯車2段減速式、自動ブレーキ付、 高低速切換装置付、圧力補償付流量調整弁付 シングルウインチ2基
旋回装置	油圧モータ駆動、遊星歯車減速機付 (ネガティブブレーキ内蔵)×2 フリー・ロック切換式、高低速切換式
旋回サークル	ローラーベアリング式、Cリング上下分割式
旋回後端半径	4,440mm (カウンタウエイト無し)
ロープ (主巻) (補巻)	φ24×360m φ24×360m
カウンタウエイト	80t・60t・40t・25t・10t
運転室	キャブ振出・チルト装置付

5. アウトリガ

形式	油圧垂直支持式 (サイドサポート併用)
張出幅	9,400 mm (最大張出) 8,400 mm (中間張出) 7,400 mm (中間張出) 6,400 mm (中間張出) 5,400 mm (中間張出)

6. クレーン用エンジン

名 称	三菱 6D24-TE1
型 式	水冷4サイクル直列6気筒 直接噴射式ディーゼルエンジン ターボ付
総排気量	11.94L
最大出力	188kW (255PS)/1,800min ⁻¹
最大トルク	1,079N・m (110kgf・m)/1,400min ⁻¹
燃料タンク容量	300L
電気システム	24V
バッテリー	115F51×2

- | | |
|-----------|--|
| 7. 油圧装置 | |
| オイルポンプ | 2連斜軸型バリアブルピストンポンプ+2連ギヤポンプ |
| オイルモータ | 巻上用 斜板型2速ピストンモータ
旋回用 斜板型ピストンモータ |
| コントロールバルブ | マルチプル自動復元式 (圧力補償付流量調整弁付) |
| シリンダ | ダブルアクティング式 |
| オイルリザーバ | 1,700L |
| 8. 安全装置 | ACS (全自動過負荷防止装置、音声警報装置付)、作業範囲制限装置
アウトリガ張出幅自動検出装置、旋回位置検出装置、過巻防止装置
ブーム自然降下防止装置、ドラムロック装置、ドラム回転計、
ドラムホールド安全装置、自動ブレーキ装置、乱巻防止装置、
油圧安全弁、アウトリガロック装置、旋回ロック装置、ACS外部表示灯、
風速計、スタンション、旋回音声警報 |
| 9. 標準装置 | エアーコンディショナ、オイルクーラ、AM/FMラジオ、
作業灯、リモコン式サーチライト、ドラム監視カメラ
間欠付フロント&天井ワイパー (ウォッシャー付)、
フロアカーペット、シガーライター |

キャリヤ部主要諸元

1. 車名及び型式	カトウ KA6350
2. 走行性能 (台車のみ)	
最高速度	75km/h
登坂能力	0.5 (tan θ)
最小回転半径	11.6m
3. 寸法・重量 (台車のみ)	
全 長	14,710mm
全 幅	3,000mm
全 高	2,820mm
軸 距	2,770+1,950+1,650+1,700+1,650=9,720mm
輪 距	前 輪 2,500mm 後 輪 2,500mm
乗車定員	2人
車両総重量	全重量 42,740kg 前 軸 16,580kg (1軸+2軸) 後 軸 26,160kg (3軸+4軸+5軸+6軸)
4. エンジン	
名 称	ベンツ OM502LA
型 式	水冷4サイクルV型8気筒 電子制御ディーゼルエンジン (インタークーラターボ付)
総排気量	15.928L
最大出力	390kW (530PS)/1,800min ⁻¹
最大トルク	2,400N・m (245kgf・m)/1,080min ⁻¹
電気システム	24V
バッテリー	145G51×2

5. 下部走行体の装置及び構造

走行駆動形式	8輪駆動 (12×8)
トルクコンバータ形式	3要素 1段 (自動ロックアップクラッチ付)
変速機型式	フルオートマチック (流体式リターダ付)
変速段数	前進5段 後退1段 副変速機 (High-Low切換付)
車軸型式	第1軸 逆エリオット式 (ステア) 第2軸 全浮動式 (ドライブ、ステア、減速機、デフロック付) 第3軸 逆エリオット式 (ステア) 第4軸 全浮動式 (ドライブ、減速機、デフロック、インターアクスルデフロック付) 第5軸 全浮動式 (ドライブ、ステア、減速機、デフロック、 インターアクスルデフロック付) 第6軸 全浮動式 (ドライブ、ステア、減速機、デフロック付)
懸架装置	ハイドロニューマチックサスペンション (サスペンションロック機構付)
ブレーキ装置	主ブレーキ 2系統空気式全輪制動 駐車ブレーキ 空気式車輪制動形スプリングブレーキ (3, 4, 5, 6軸) 補助ブレーキ エンジンブレーキ (圧縮ブレーキ)、排気ブレーキ、流体式リターダ 非常ブレーキ 駐車ブレーキと兼用
ステアリング装置 形式	セミインテグラル式パワーステアリング 非常用パワーステアリング付 1, 2, 3軸—同位相操向 5, 6軸—逆位相操向
タイヤサイズ 前輪	445/95 R25 177E ROAD
後輪	445/95 R25 177E ROAD
燃料タンク容量	500L

6. 安全装置

緊急用かじ取装置、オーバーラン警報装置、3点式シートベルト (運転席)、サスペンションロック装置、電動式サイドミラー (左側)、警告反射板、エンジン電子制御装置、トランスミッション電子制御装置、ラジエータ液面警報装置、ローエア警報装置、ブレーキランプ・スモールランプ断線警報装置

- | | |
|------------|---|
| 7. 標準装置 | チルト/テレスコピックステアリングホイール、エアコンディショナ、パワーウインドウ、サスペンション付マルチアジャスタブルシート、タコグラフ、サンバイザー、集中給脂装置、エアードライヤ、AM/FMラジオ、前後牽引フック |
| 8. オプション装置 | 後方確認カメラ |

※本仕様は、改良などにより予告なく変更する事があります。

【注意】

1. 本機は公道走行をする場合、旋回体およびブームを別送し台車のみで走行しなければなりません。
2. 道路を通行する場合には、道路法により通行の許可と道路運送車両法による保安基準の緩和が必要です。
3. KA6350型は、新規開発車両証明制度による適合証明書「基本通行条件 重量:C」の交付を受けていますが、実際の運行条件は、運行経路ごとの道路管理者の算定結果によって付与されます。
4. 構内を移動する時に限り、構内走行姿勢図のような状態で移動できます。
ただし、走行速度は25km/h以下で走行してください。
5. クレーンの旋回体にカウンタウエイトを装着しているときは、必ずアウトリガを使用した状態にしてください。

■ 全体図

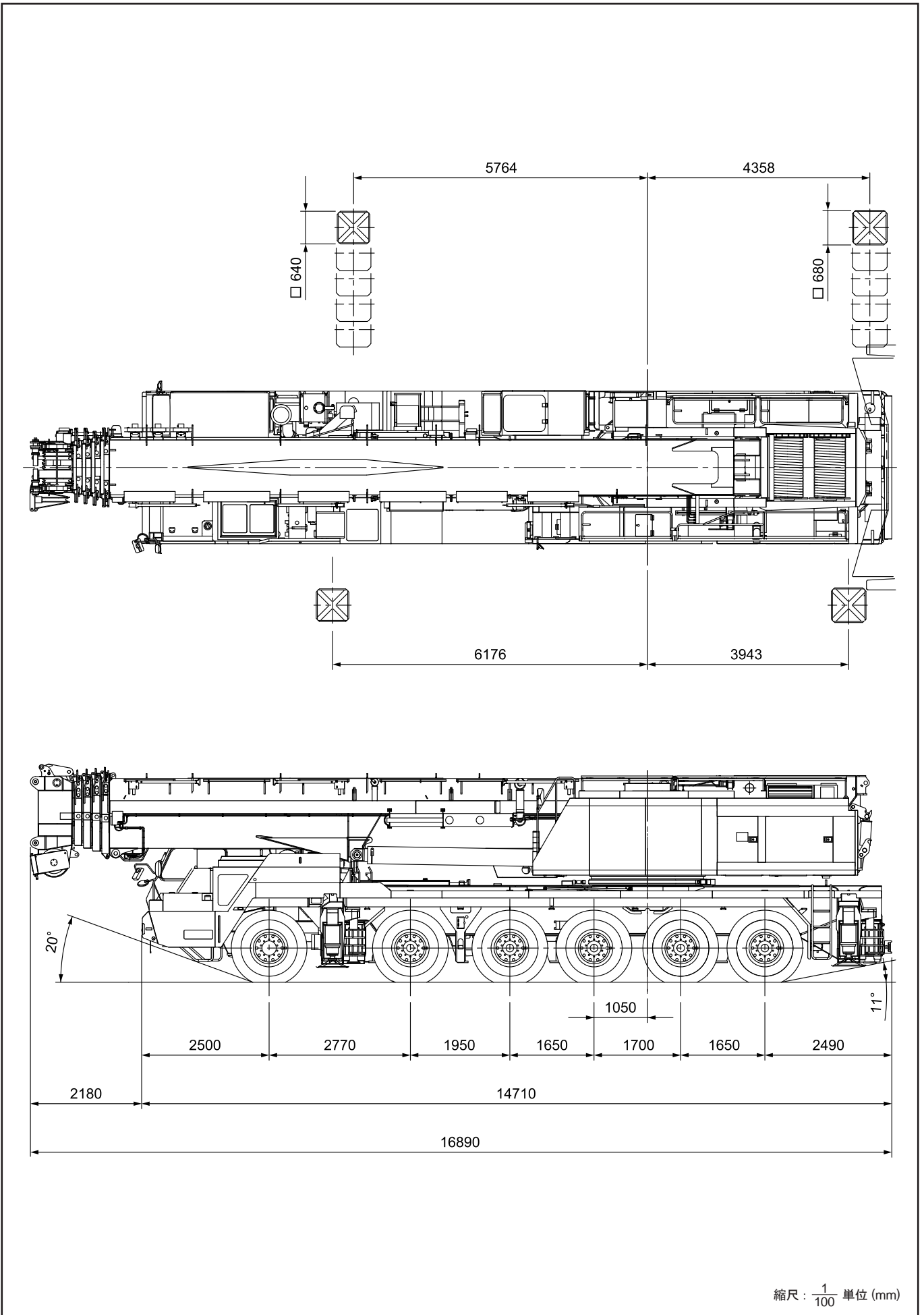

縮尺： $\frac{1}{100}$ 単位 (mm)

■全体図

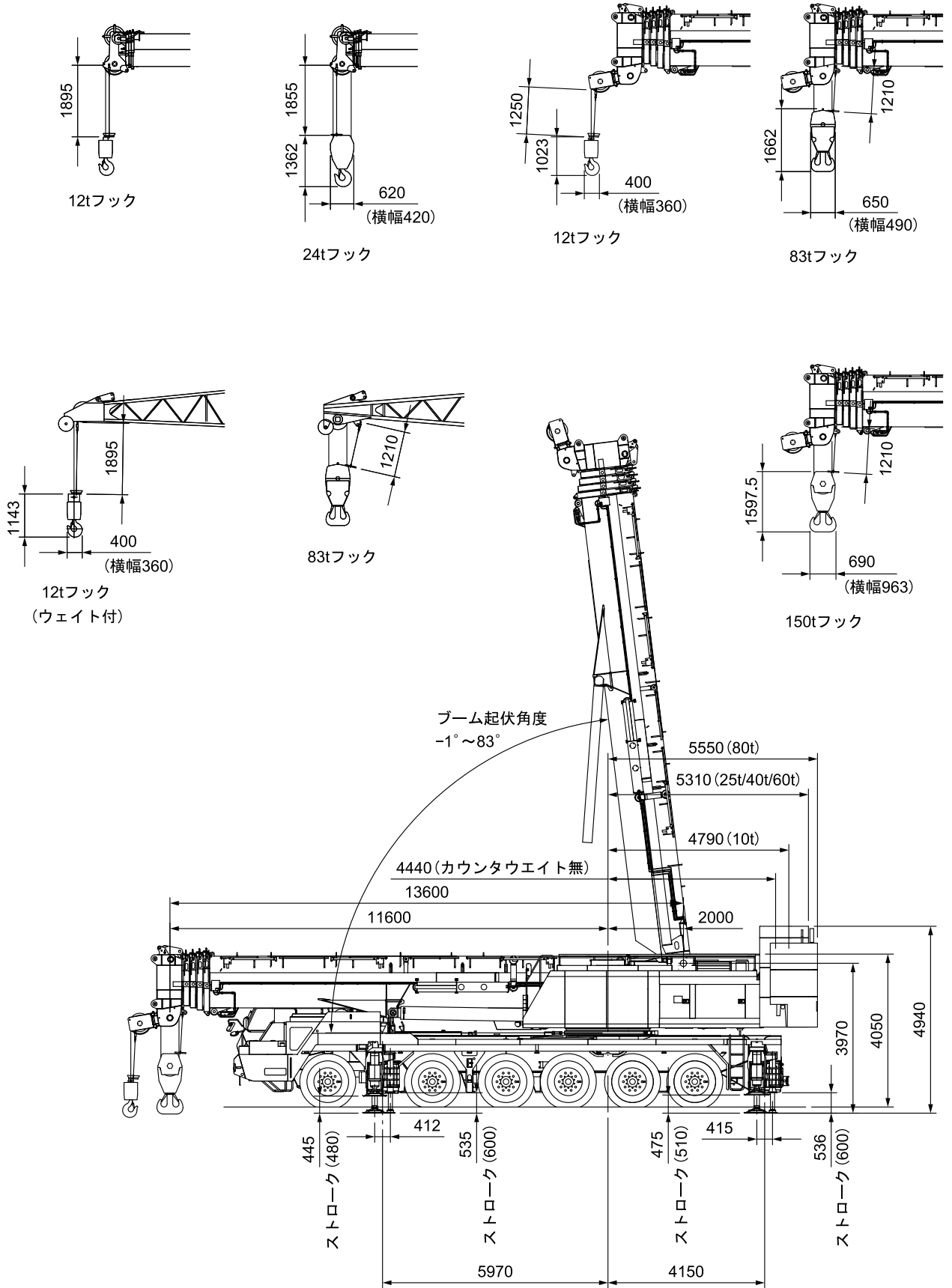

縮尺: $\frac{1}{150}$ 単位 (mm)

■全体図

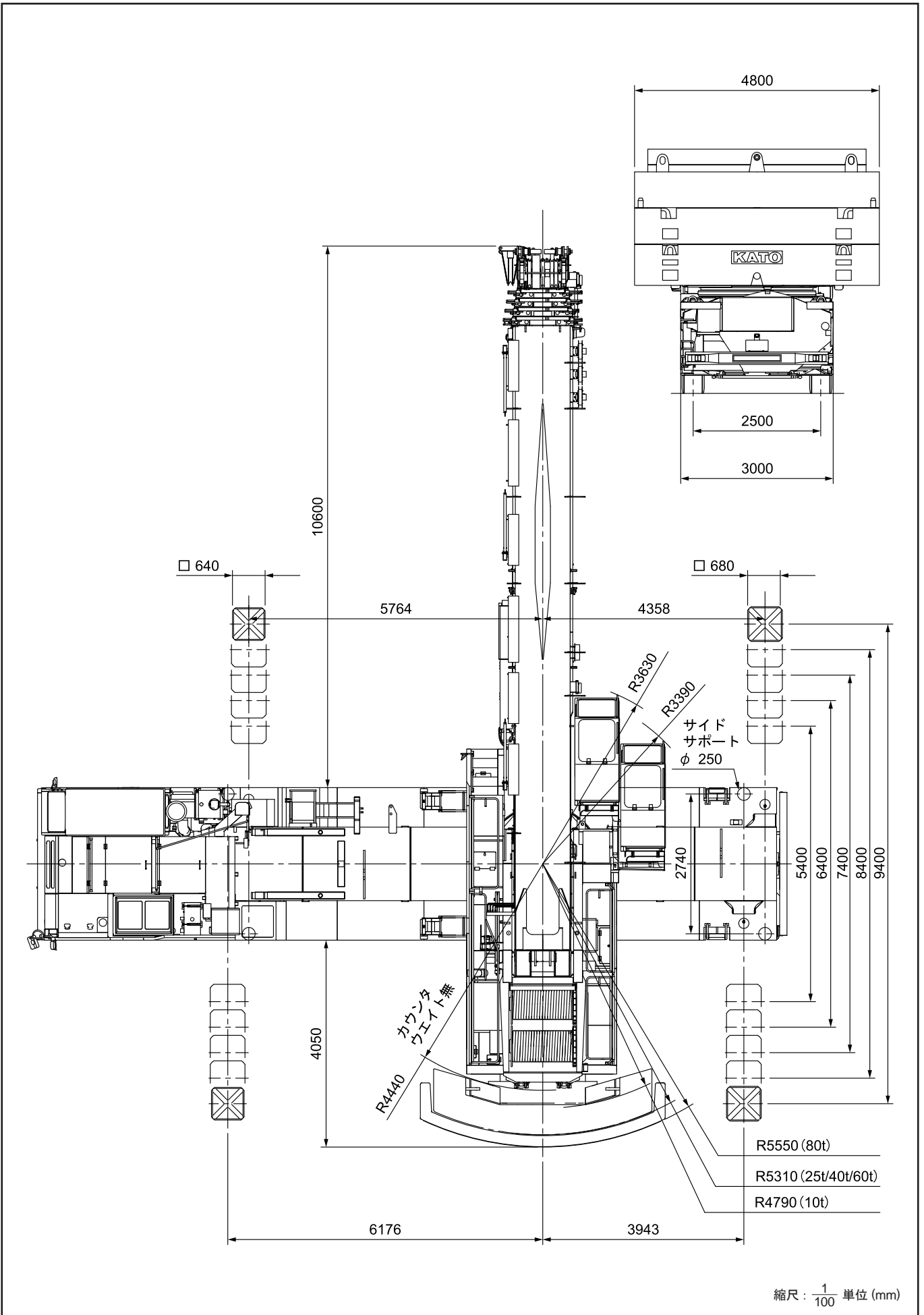

■最小直角通路幅

●構内走行時

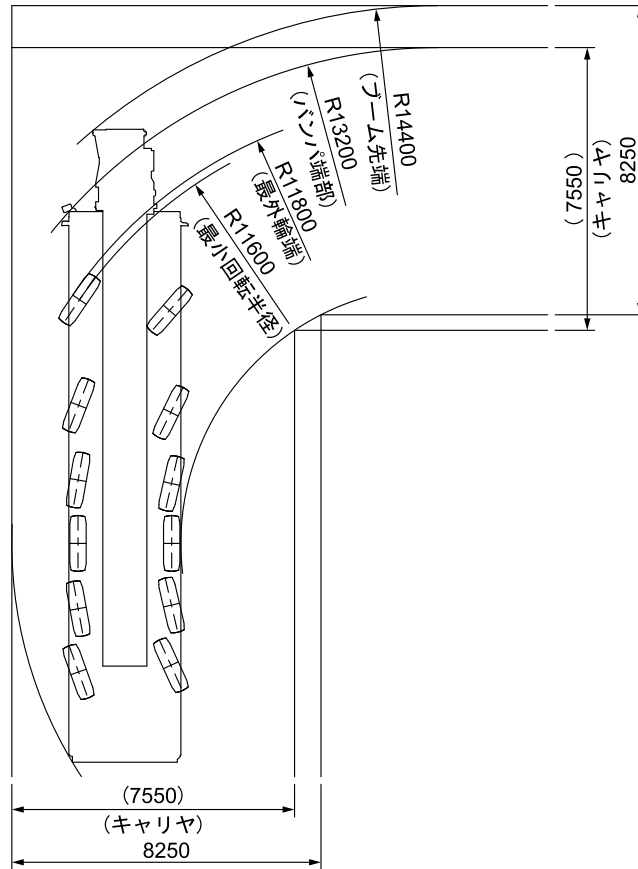

■公道走行状態

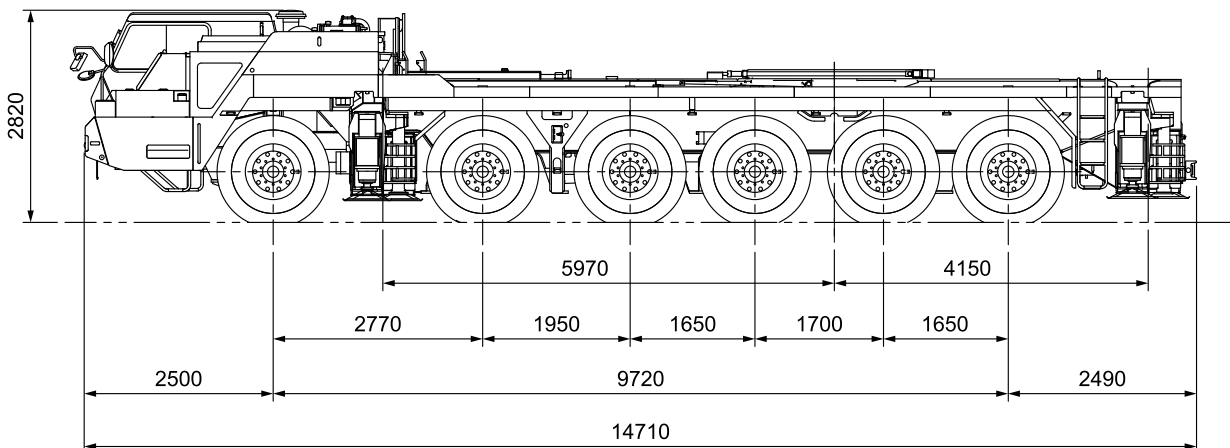
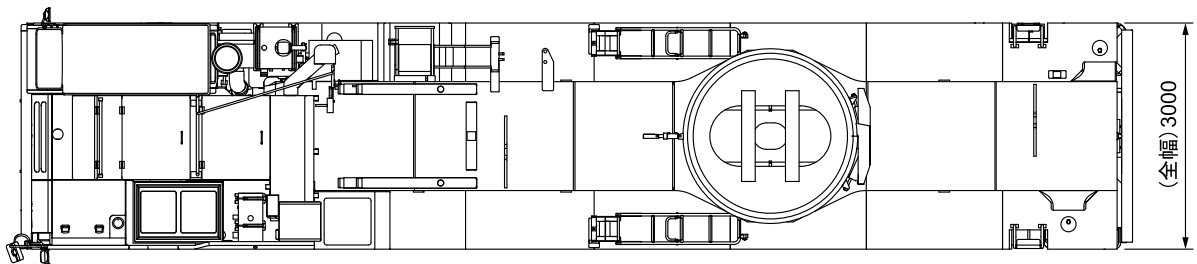

縮尺: $\frac{1}{100}$ 単位 (mm)

■寸法・重量関係

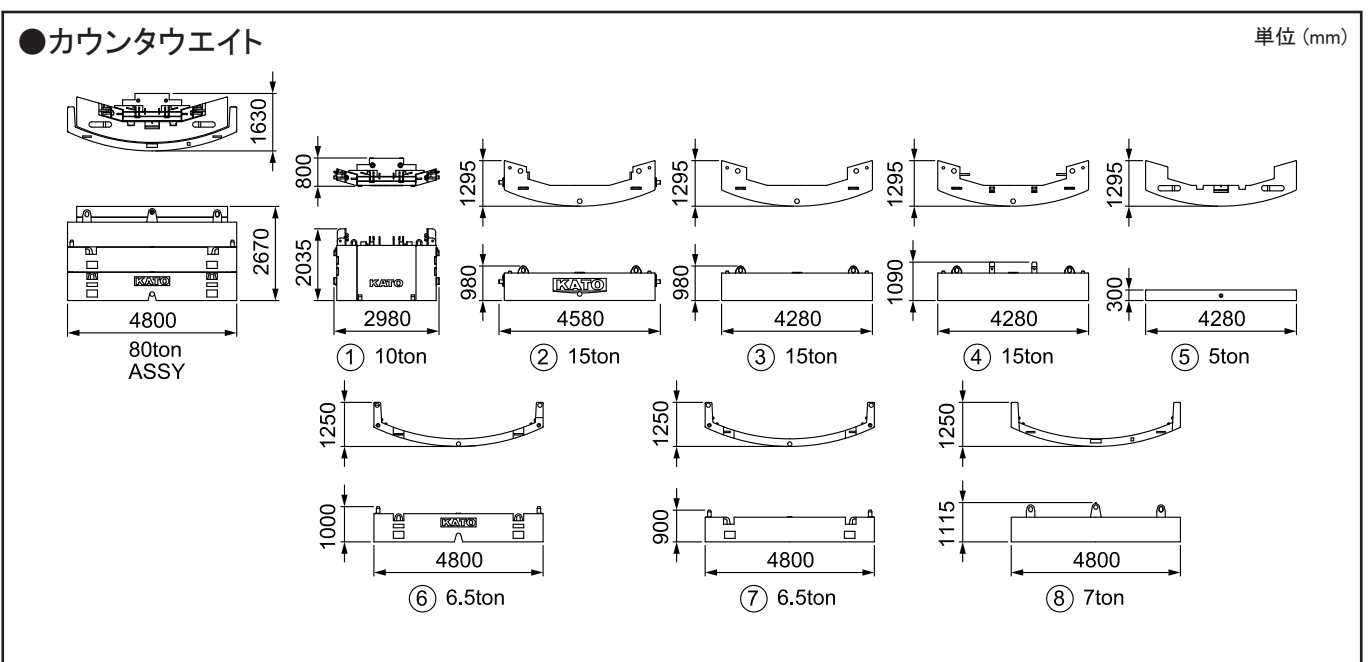
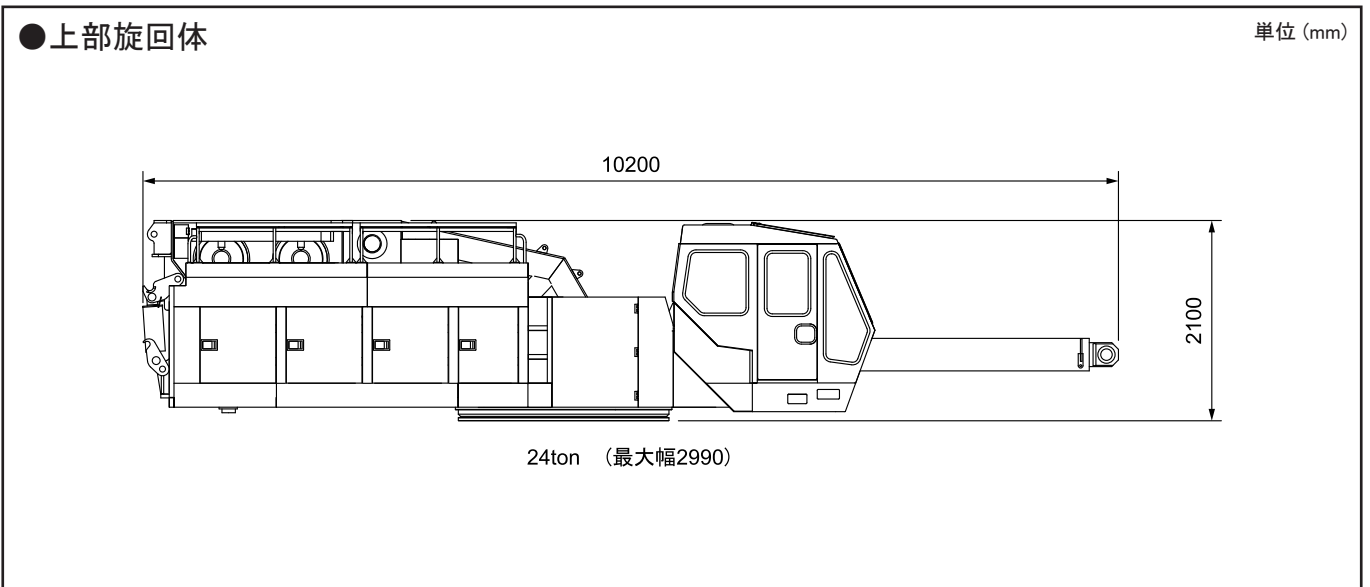
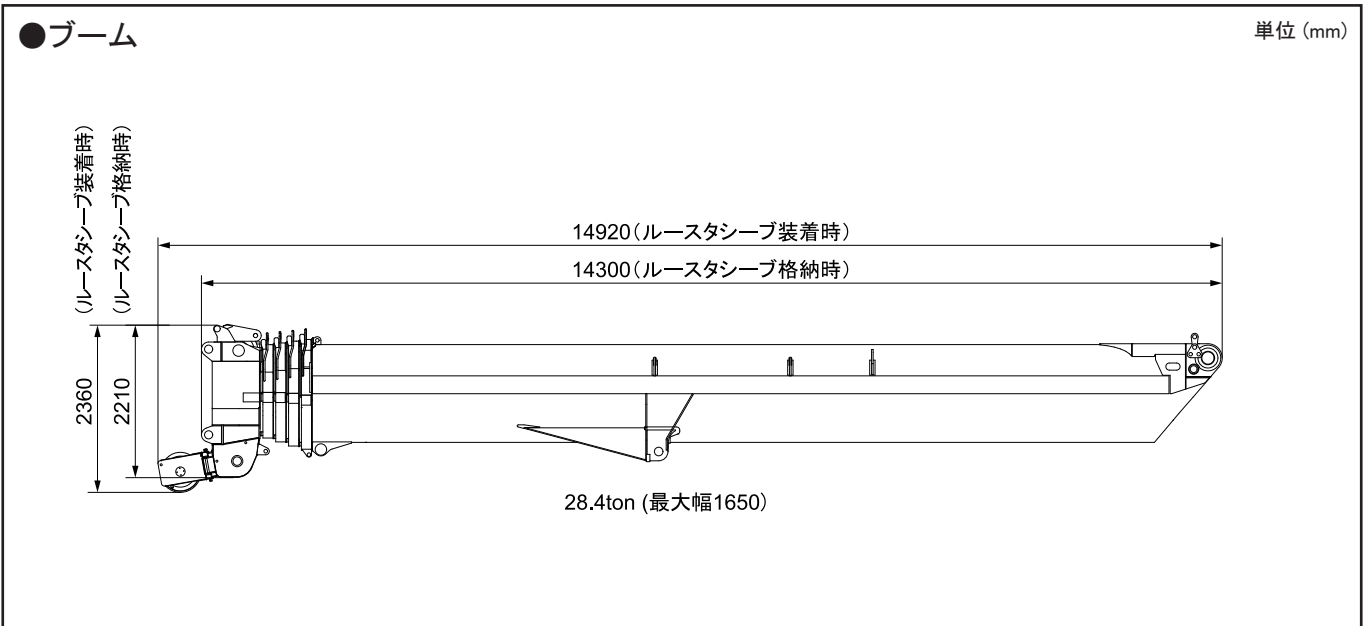

作業範囲図

■ 重荷重吊り上げ装置付 作業範囲図	41
■ ブーム・ルースターシーブ 作業範囲図	42
■ スーパーラフティングジブ(SLジブ) 作業範囲図 ...	45
■ ヘビーリフトジブ(HLジブ) 作業範囲図	52

重荷重吊り上げ装置付 作業範囲図

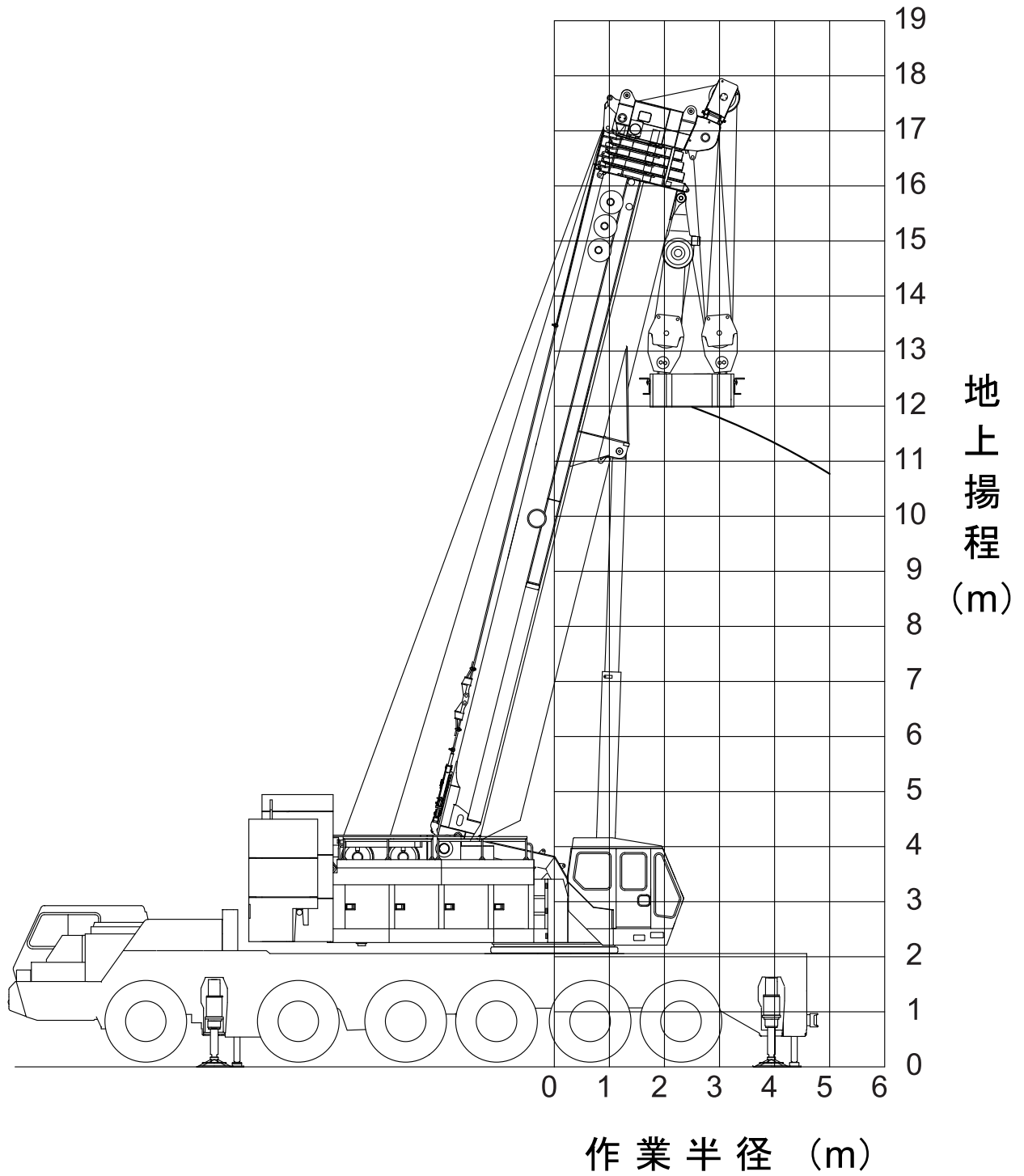

注) 本図は、ブームのたわみを含んでいません。

ブーム・ルースターシーブ 作業範囲図 【通常伸縮】

- | | |
|-------------|----------------------|
| Ⓐ13.6m ブーム | ⓓ13.6m ブーム+ルースターシーブ |
| Ⓑ18.15m ブーム | ⓞ18.15m ブーム+ルースターシーブ |
| Ⓒ22.7m ブーム | ⓟ22.7m ブーム+ルースターシーブ |
| Ⓓ31.8m ブーム | ⓠ31.8m ブーム+ルースターシーブ |
| Ⓔ40.9m ブーム | ⓡ40.9m ブーム+ルースターシーブ |
| Ⓕ45.5m ブーム | ⓢ45.5m ブーム+ルースターシーブ |
| Ⓖ50.0m ブーム | ⓣ50.0m ブーム+ルースターシーブ |

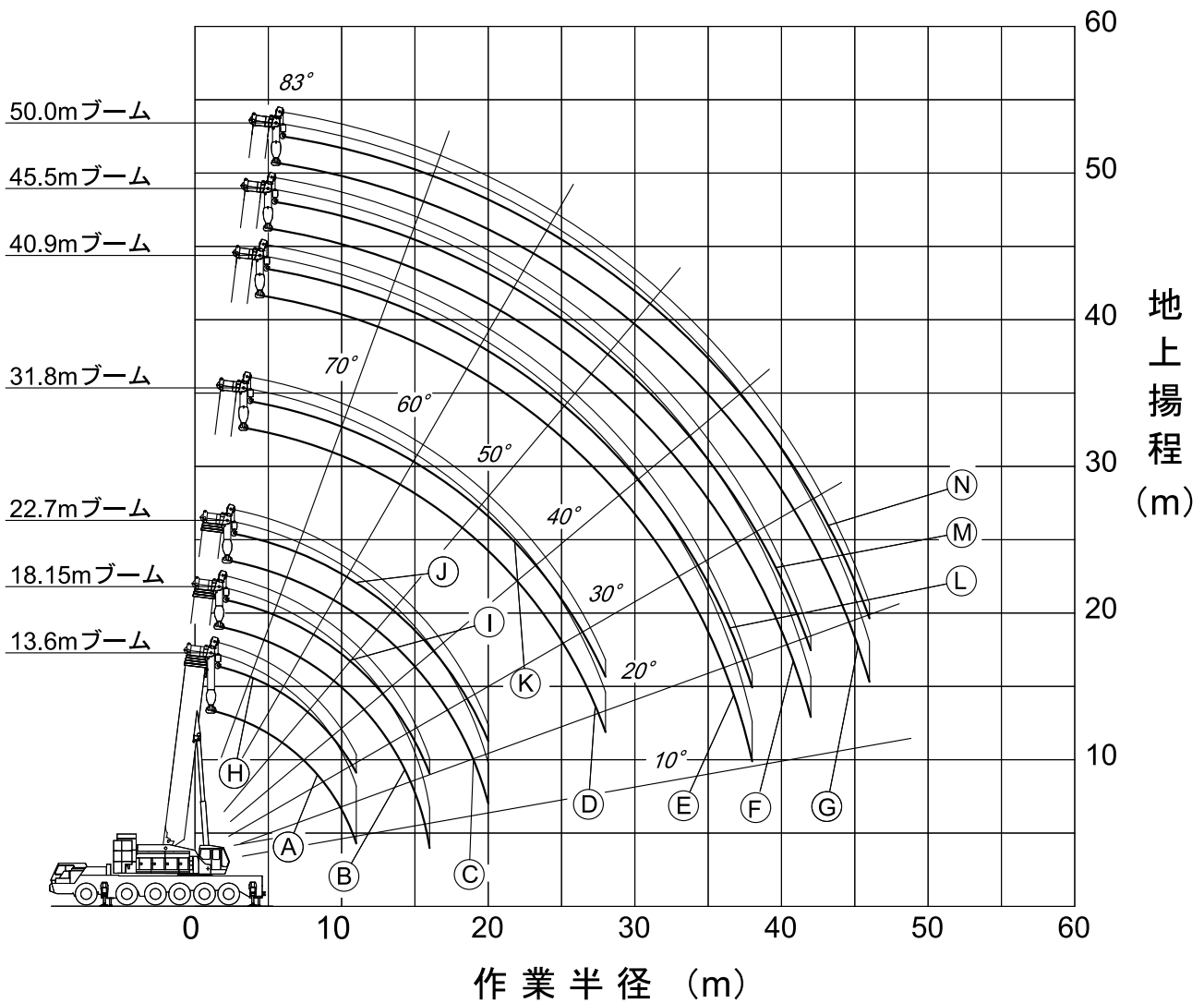

注) 1. 本図は、ブームのたわみを含んでいません。
2. A1 ~ A3、B1 ~ B3、C1性能の最大作業半径を図示しています。

KA-3000 (メインブーム) 作業概念図

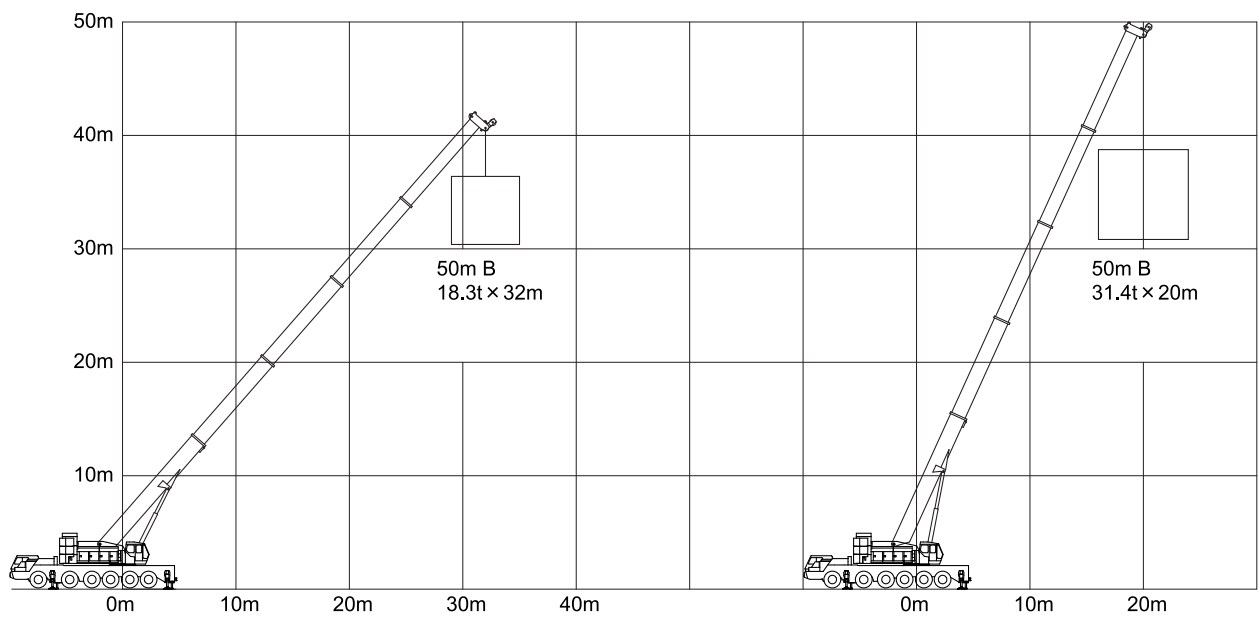
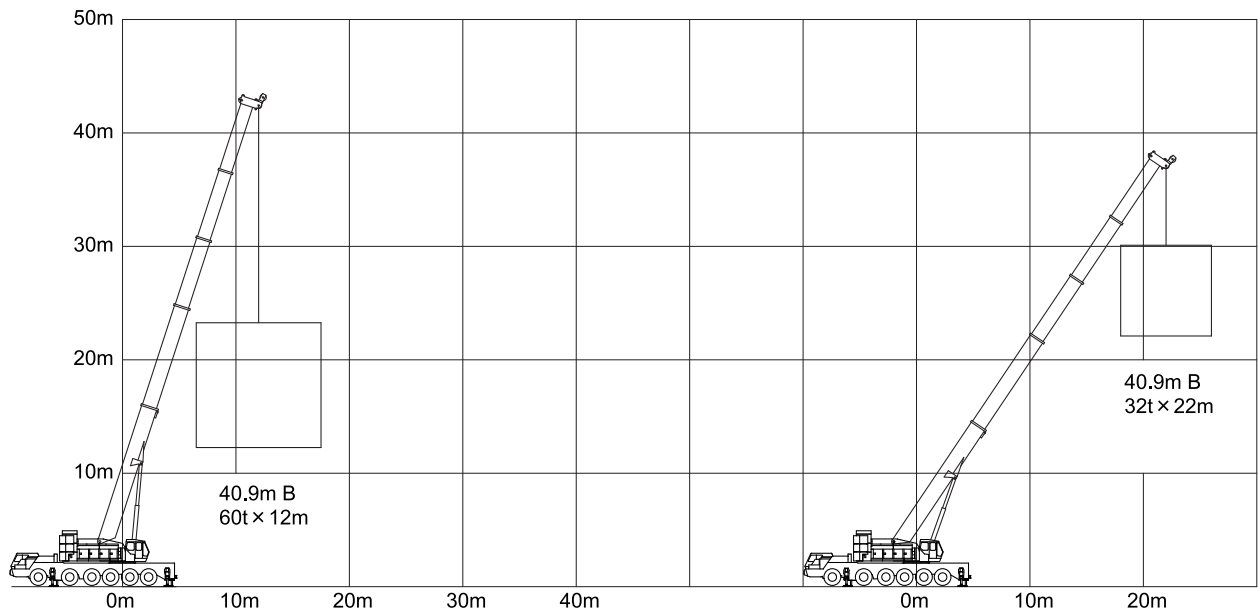

ブーム・ルースターシーブ 作業範囲図 【特殊伸縮】

- Ⓐ13.6mブーム
- Ⓑ22.7mブーム
- Ⓒ31.8mブーム
- Ⓓ40.9mブーム
- Ⓔ13.6mブーム+ルースターシーブ
- Ⓕ22.7mブーム+ルースターシーブ
- Ⓖ31.8mブーム+ルースターシーブ
- Ⓗ40.9mブーム+ルースターシーブ

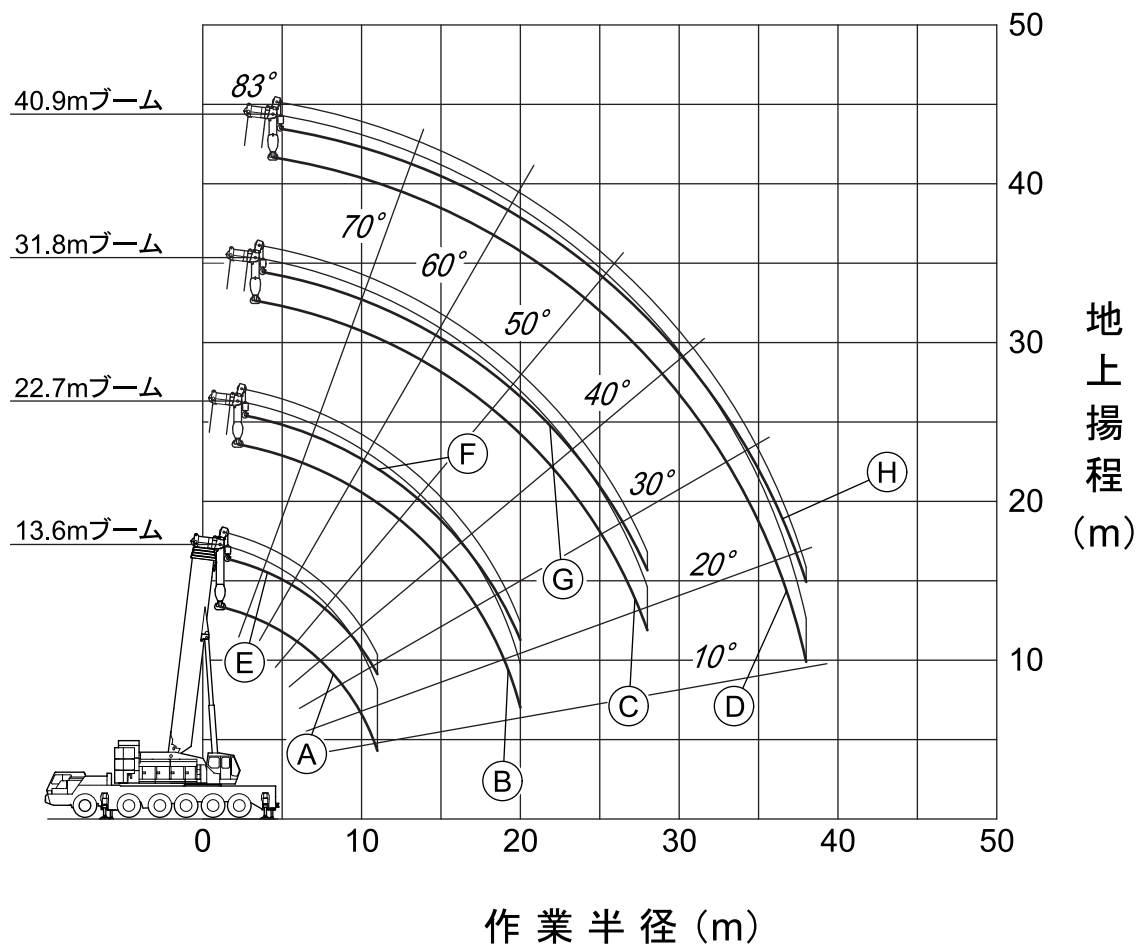

- 注) 1. 本図は、ブームのたわみを含んでいません。
2. TA1 ~ TA3, TB1 ~ TB4, TC1 ~ TC4, TD1 ~ TD2性能の最大作業半径を図示しています。

スーパーラフィングジブ (SLジブ) 作業範囲図 【40.9mブーム時】

40.9mブーム+2.0m+10.0mSLジブ (オフセット 5°~ 60°) 40.9mブーム+2.0m+23.0mSLジブ (オフセット 5°~ 60°)
 40.9mブーム+2.0m+15.0mSLジブ (オフセット 5°~ 60°) 40.9mブーム+2.0m+27.0mSLジブ (オフセット 5°~ 60°)
 40.9mブーム+2.0m+19.0mSLジブ (オフセット 5°~ 60°) 40.9mブーム+2.0m+31.0mSLジブ (オフセット 5°~ 60°)

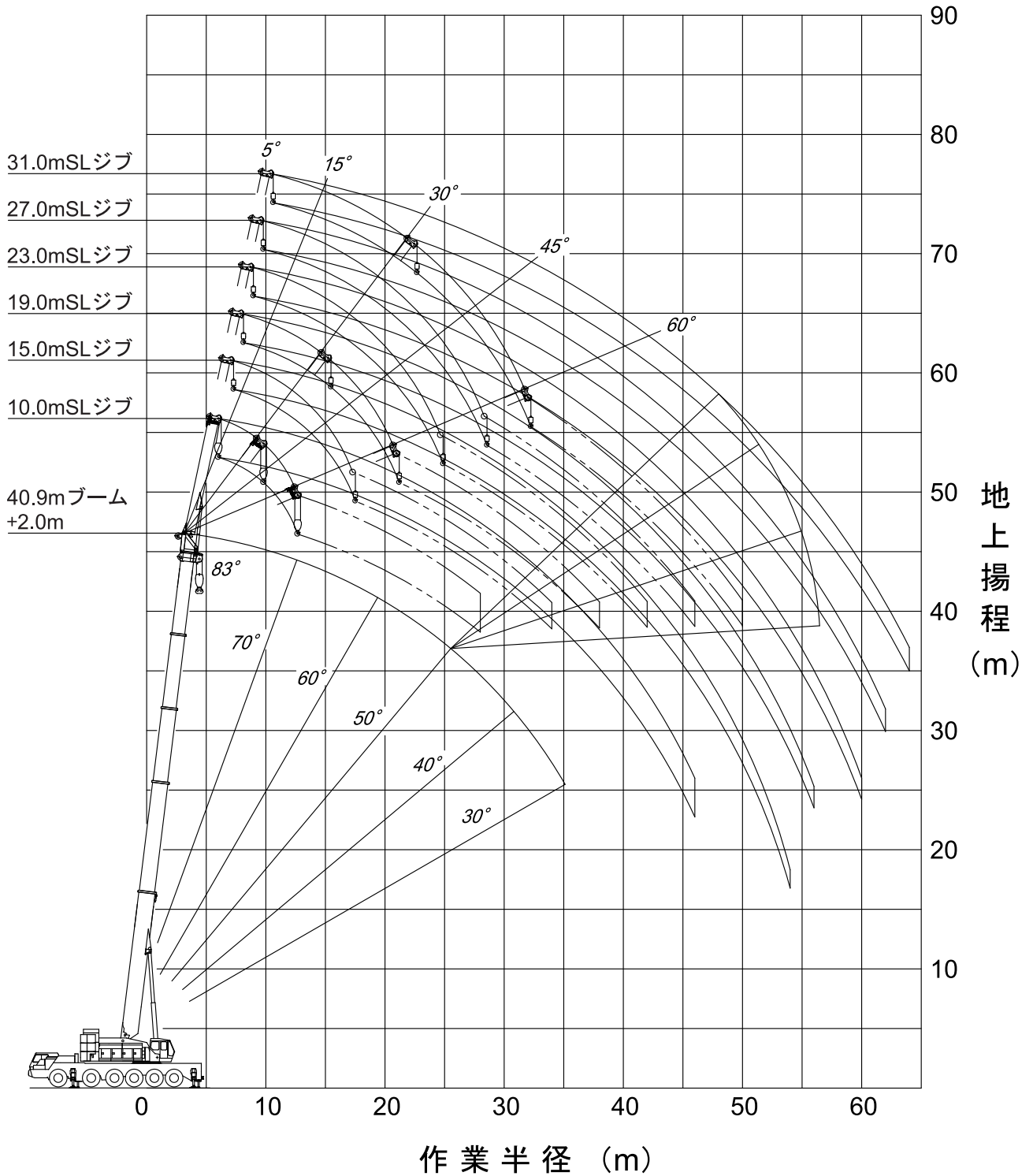

注) 1. 本図は、ブームおよびSLジブのたわみを含んでいません。
 2. SA性能の最大作業半径を図示しています。

スーパーラフティングジブ (SLジブ) 作業範囲図 【50mブーム時】

50.0mブーム+2.0m+10.0mSLジブ (オフセット5°~ 60°) 50.0mブーム+2.0m+23.0mSLジブ (オフセット5°~ 60°)
 50.0mブーム+2.0m+15.0mSLジブ (オフセット5°~ 60°) 50.0mブーム+2.0m+27.0mSLジブ (オフセット5°~ 60°)
 50.0mブーム+2.0m+19.0mSLジブ (オフセット5°~ 60°) 50.0mブーム+2.0m+31.0mSLジブ (オフセット5°~ 60°)

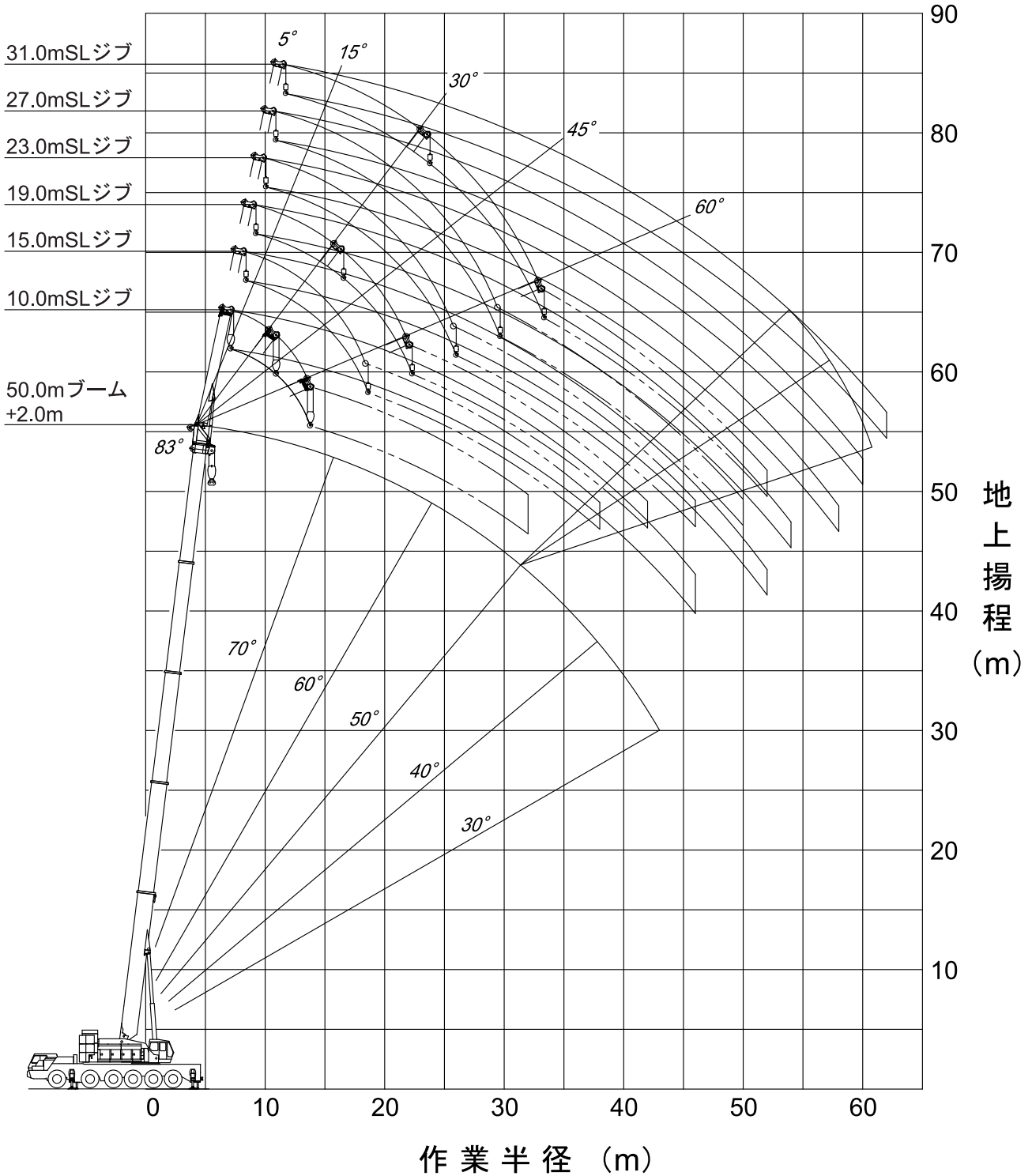

注) 1. 本図は、ブームおよびSLジブのたわみを含んでいません。
 2. SA性能の最大作業半径を図示しています。

スーパーラフングジブ (SLジブ) 作業概念図

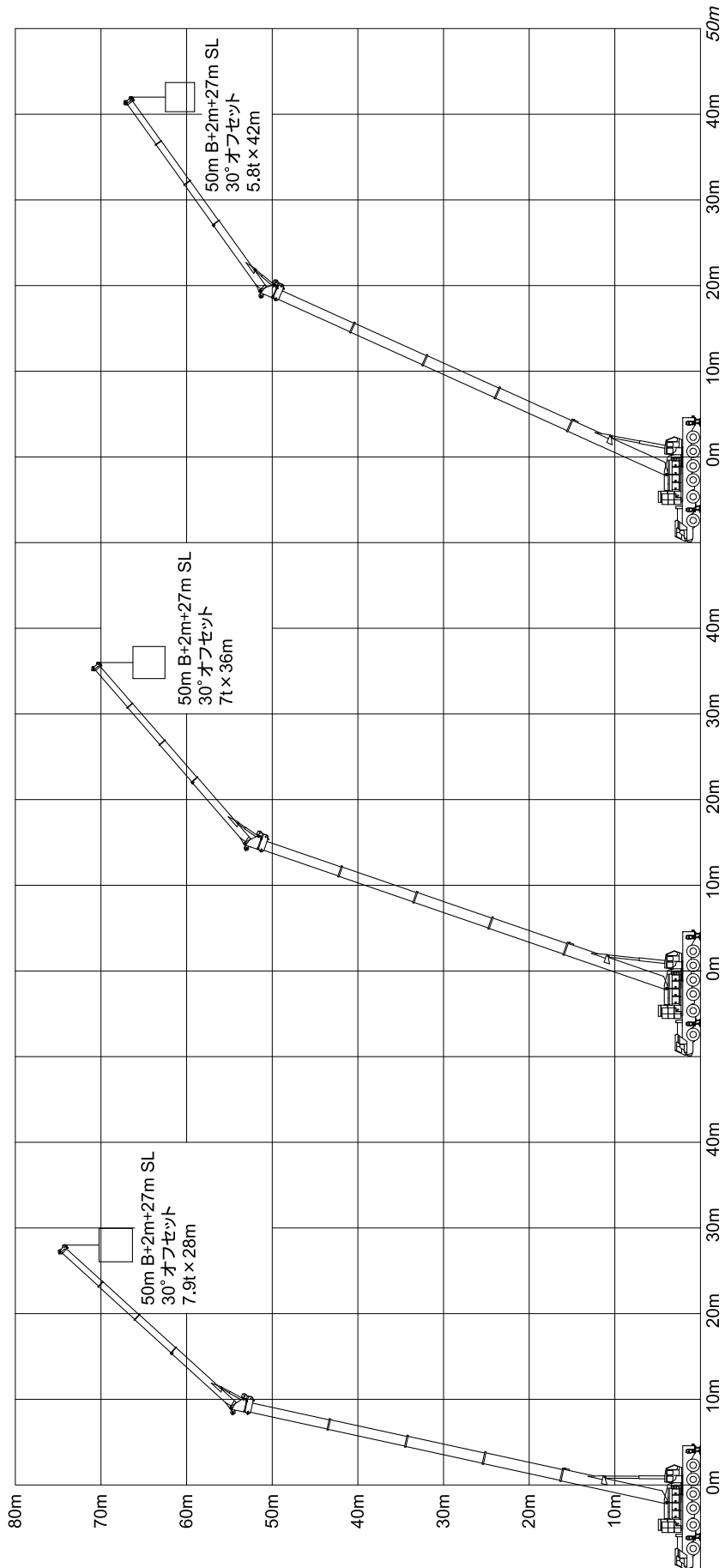

スーパーラフングジブ (SLジブ) 作業概念図

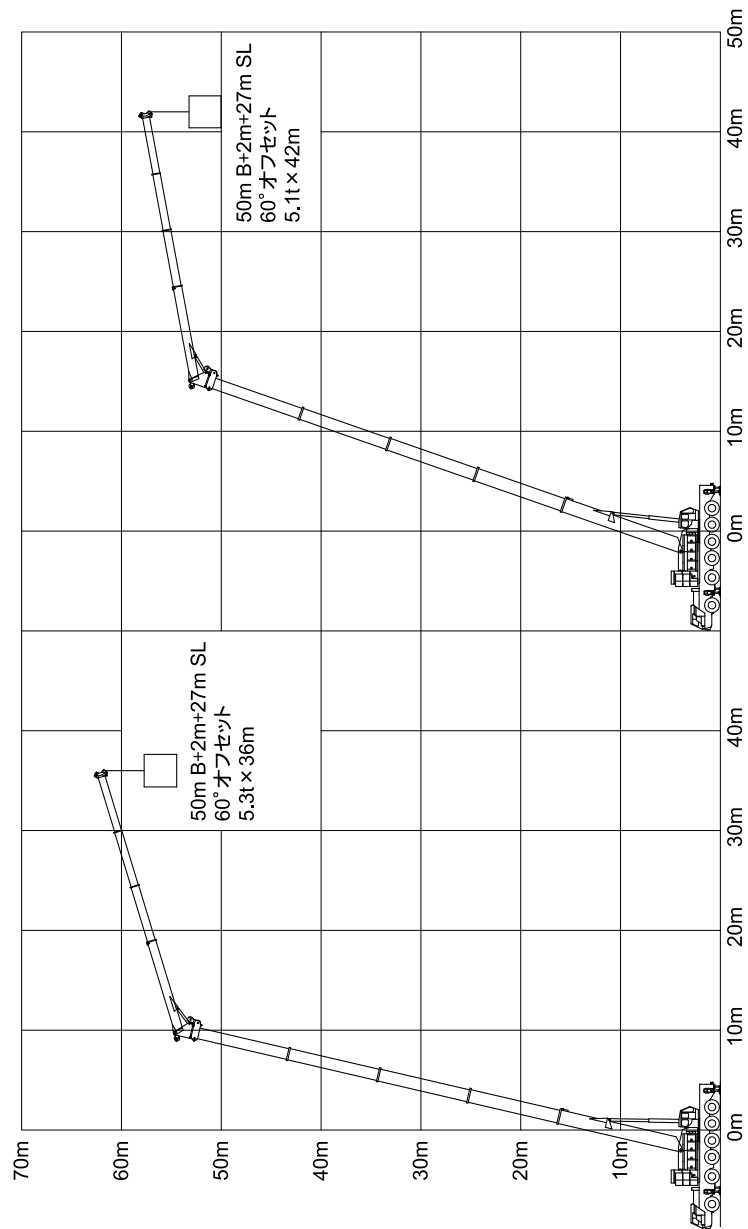

スーパーラフングジブ (SLジブ) 作業概念図

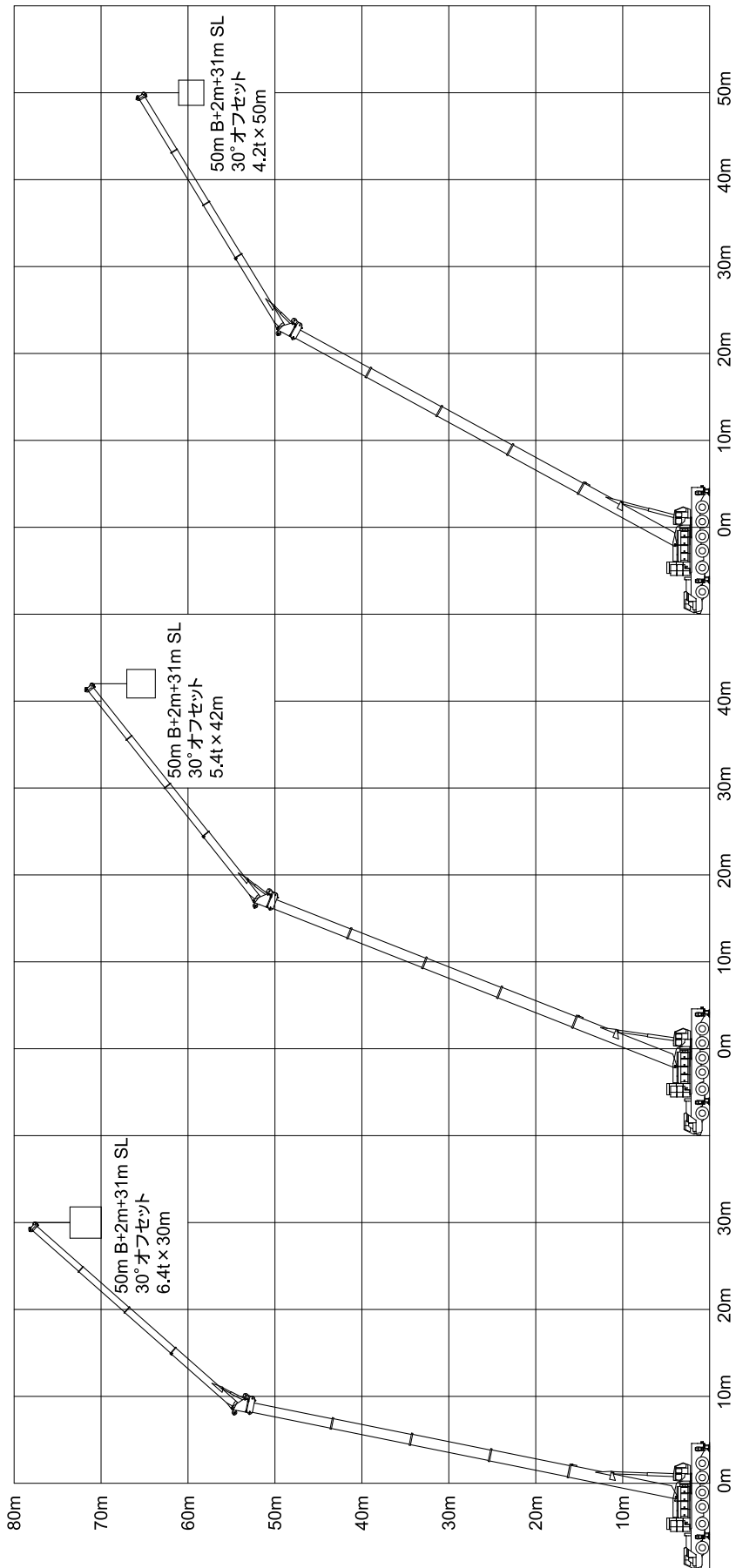

スーパーラフングジブ (SLジブ) 作業概念図

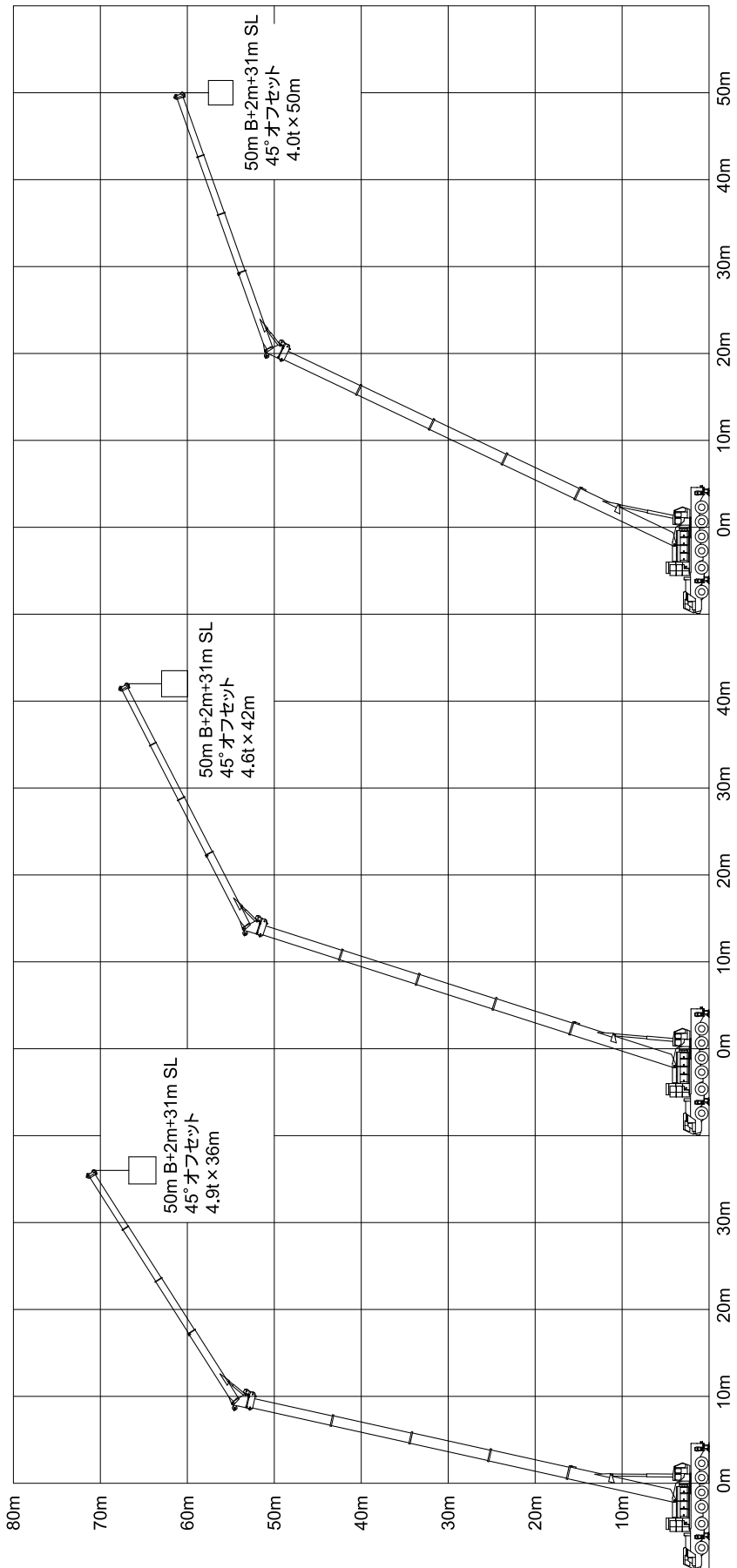

スーパーラフィングジブ (SLジブ) 作業概念図

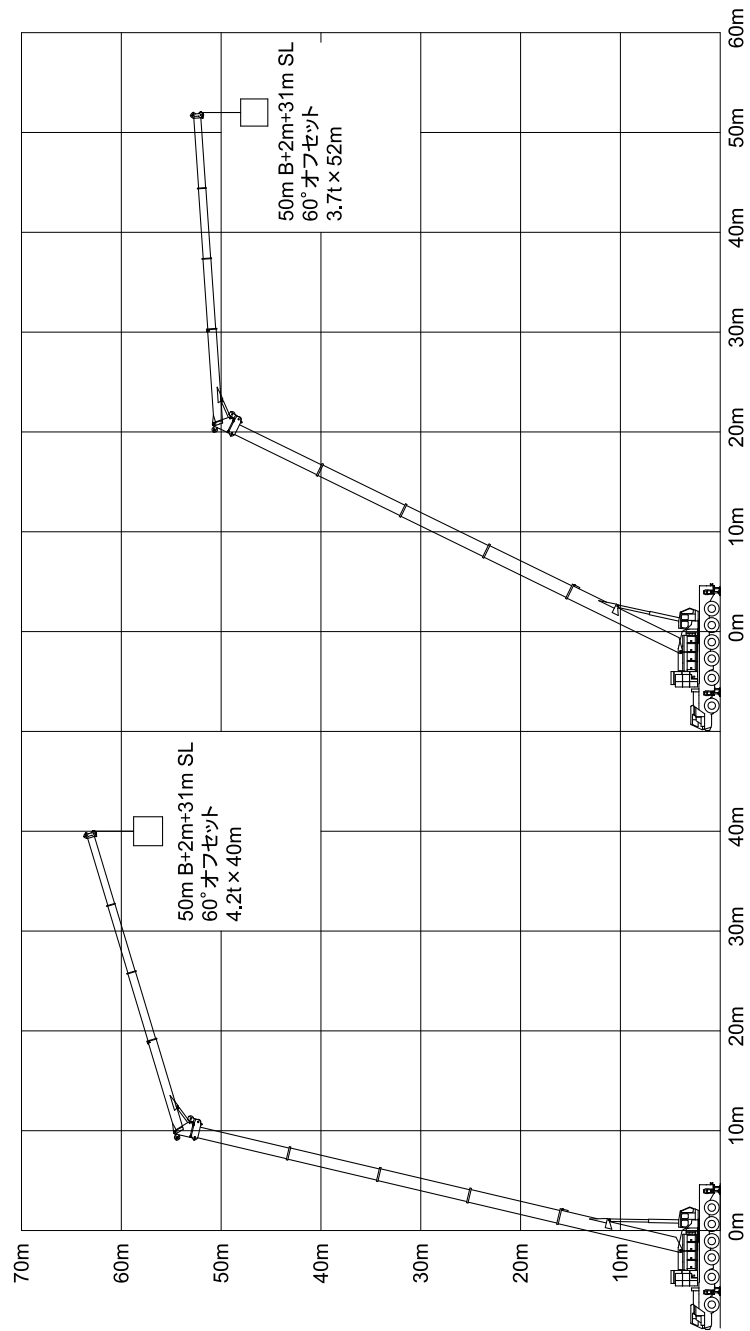

ヘビーリフトジブ(HLジブ) 作業範囲図

- | | | | | | |
|---|--|---|--|---|--------------------------|
| ① | 13.6mブーム+4.4m +13mヘビーリフトジブ (オフセット 10°) | ⑭ | 50.0mブーム+4.4m +22mヘビーリフトジブ (オフセット 10°) | ⑳ | +31mヘビーリフトジブ (オフセット 10°) |
| ② | +22mヘビーリフトジブ (オフセット 10°) | ㉑ | +40mヘビーリフトジブ (オフセット 10°) | ㉒ | +47mヘビーリフトジブ (オフセット 10°) |
| ③ | +31mヘビーリフトジブ (オフセット 10°) | ㉓ | +54mヘビーリフトジブ (オフセット 10°) | ㉔ | +22mヘビーリフトジブ (オフセット 60°) |
| ④ | +40mヘビーリフトジブ (オフセット 10°) | ㉕ | +31mヘビーリフトジブ (オフセット 60°) | ㉖ | +40mヘビーリフトジブ (オフセット 60°) |
| ⑤ | +47mヘビーリフトジブ (オフセット 10°) | ㉗ | +47mヘビーリフトジブ (オフセット 60°) | ㉘ | +54mヘビーリフトジブ (オフセット 60°) |
| ⑥ | +54mヘビーリフトジブ (オフセット 10°) | ㉙ | +40mヘビーリフトジブ (オフセット 60°) | ㉚ | +47mヘビーリフトジブ (オフセット 60°) |
| ⑦ | +13mヘビーリフトジブ (オフセット 60°) | ㉛ | +54mヘビーリフトジブ (オフセット 60°) | | |
| ⑧ | +22mヘビーリフトジブ (オフセット 60°) | | | | |
| ⑨ | +31mヘビーリフトジブ (オフセット 60°) | | | | |
| ⑩ | +40mヘビーリフトジブ (オフセット 60°) | | | | |
| ⑪ | +47mヘビーリフトジブ (オフセット 60°) | | | | |
| ⑫ | +54mヘビーリフトジブ (オフセット 60°) | | | | |
| ⑬ | | | | | |

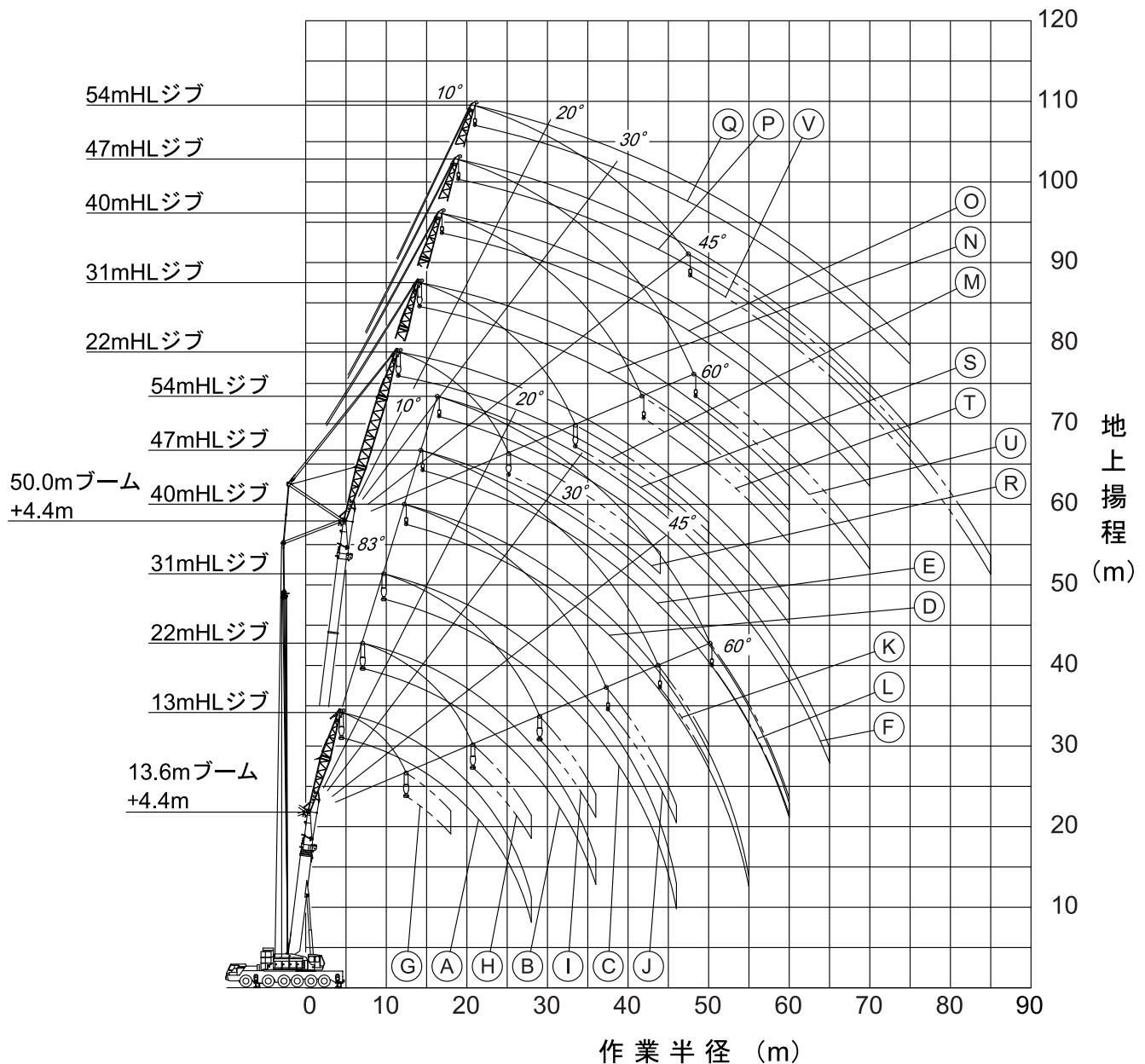

- 注) 1. 本図は、ブームおよびヘビーリフトジブのたわみを含んでいません。
 2. HA性能の最大作業半径を図示しています。

ヘビーリフトジブ (HLジブ) 作業概念図

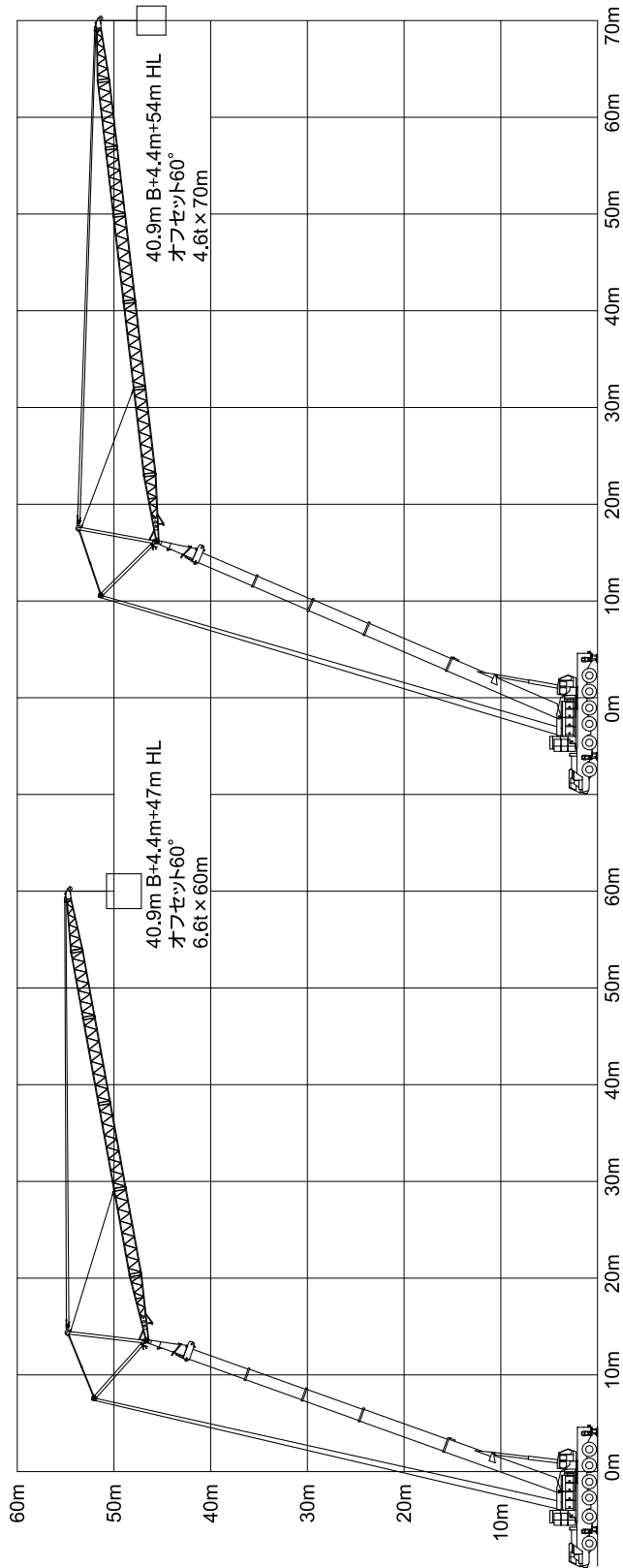

ヘビーリフトジブ (HLジブ) 作業概念図

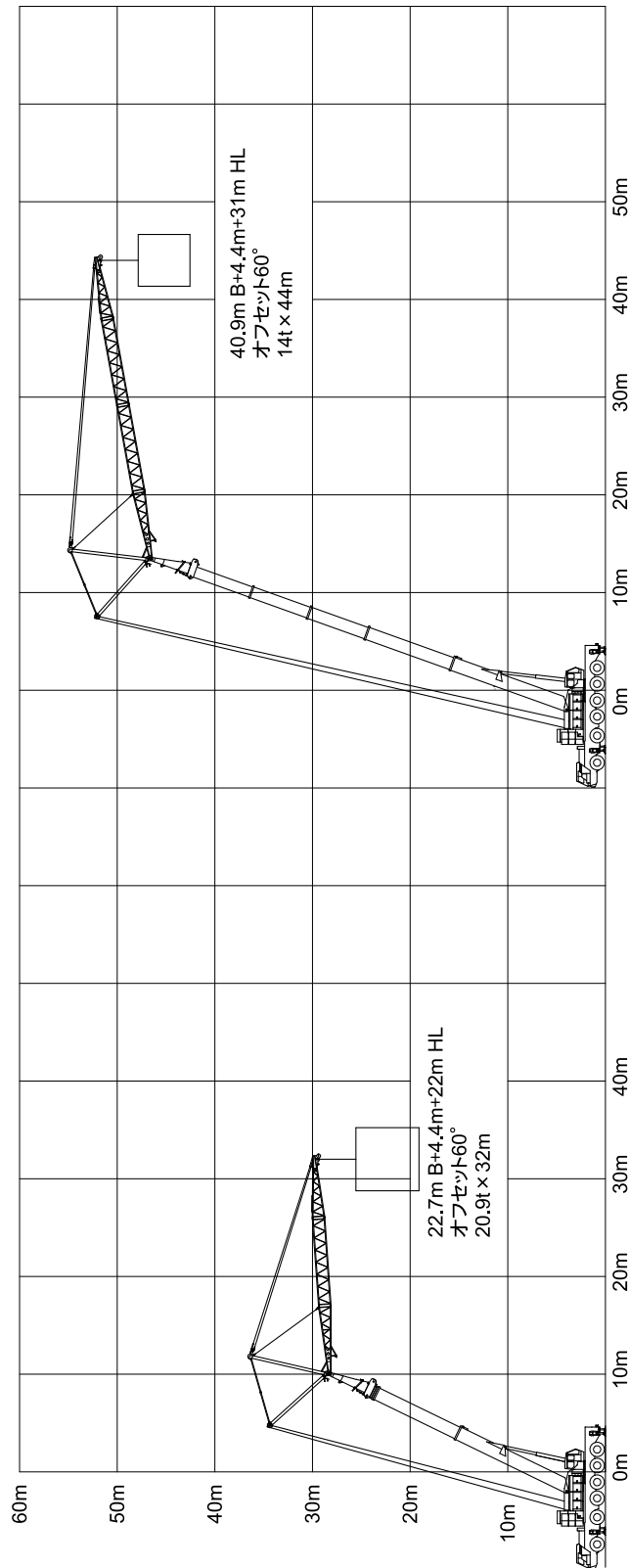

定格総荷重表注意事項

- 1) 定格総荷重は水平堅土上において本機の保証できる最大荷重を示しており、フックその他つり具等の質量を含んだ値です。なお、太枠の内側は機械の強度によって定められ、下側は機械の安定度によって定められています。
- 2) 定格総荷重は、アウトリガ・サイドサポート・ブームロックを使用した状態で、アウトリガの張出幅とカウンタウエイトの装備状態により、下記のように区分されます。
- 3) カウンタウエイト装備状態およびアウトリガ張出状態によって、前・後方域および側方域でのつり上げ性能は異なります。

従って各々の状態に該当する定格総荷重表で作業を行ってください。

作業状態	重荷重	通常
領域 α	15°	15°
領域 β	5°	15°

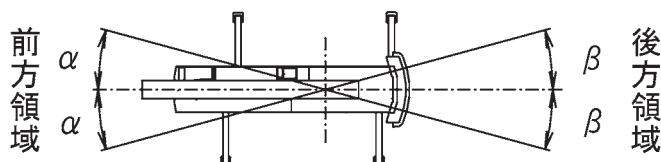

ブーム <重荷重> 【全周・後方】

吊方向	カウンタウエイト	80t
	アウトリガ張出幅	
全周*	7.4m	AA

*最大荷重は後方のみ

ブーム <通常伸縮>

吊方向	カウンタウエイト	80t	60t	40t	25t	10t	0t
	アウトリガ張出幅						
側方	9.4m	A1	B1	C1	D1	E1	F1
	8.4m	A2	B2	C2	D2	E2	F2
	7.4m	A3	B3	C3	D3	E3	F3
	6.4m	—	B4	C4	D4	E4	F4
	5.4m	—	—	C5	D5	E5	F5
前後方	9.4m ~ 7.4m	A1	B1	C1	D1	E1	F1
	6.4m	—	B1	C1	D1	E1	F1
	5.4m	—	—	C1	D1	E1	F1

ブーム <特殊伸縮>

吊方向	カウンタウエイト	80t	60t	40t	25t	10t	0t
	アウトリガ張出幅						
側方	9.4m	TA1	TB1	TC1	TD1	TE1	TF1
	8.4m	TA2	TB2	TC2	TD2	TE2	TF2
	7.4m	TA3	TB3	TC3	TD3	TE3	TF3
	6.4m	—	TB4	TC4	TD4	TE4	TF4
	5.4m	—	—	TC5	TD5	TE5	TF5
前後方	9.4m ~ 7.4m	TA1	TB1	TC1	TD1	TE1	TF1
	6.4m	—	TB1	TC1	TD1	TE1	TF1
	5.4m	—	—	TC1	TD1	TE1	TF1

特殊伸縮：2段ブームを伸ばさずに、3、4、5段ブームを等長で伸縮させる伸縮方式です。

スーパーラフィングジブ

吊方向	カウンタウエイト		80t	60t	40t	25t
	アウトリガ張出幅					
側方	9.4m		SA	SB	SC	SD
	8.4m			SC	SD	—
	7.4m		SB			—
前後方	9.4m		SA	SB	SC	SD
	8.4m ~ 7.4m		SA	SB	SC	—

ヘビーリフトジブ

吊方向	カウンタウエイト		80t	60t	40t	25t
	アウトリガ張出幅					
側方	9.4m		HA	HB	HC	HD
	8.4m			HC	HD	—
	7.4m		HB			—
前後方	9.4m		HA	HB	HC	HD
	8.4m ~ 7.4m		HA	HB	HC	—

- 4) 定格総荷重表のブーム角度は、ブームと水平面のなす角度を示し、ジブ角度はブームとジブのなす角度を示します。
- 5) 作業半径はブームのたわみを含んだ実際の値に基づいていますので、必ず作業半径を基準として作業を行ってください。但しスーパーラフィングジブの作業半径は、40.9mブーム・45.5mブーム・50.0mブームにスーパーラフィングジブを装着してジブ作業を行った時の値を示し、これより短いブーム長さでのジブ作業はジブを40.9mブームに取り付けた時のブーム角度だけを基準として行ってください。
- 6) ブーム長さ・ブーム角度・作業半径・ジブ角度が規定の値を超えた場合は、その規定の値と次の規定の値の定格総荷重のうち小さい方の定格総荷重に従って作業を行ってください。
- 7) 定格総荷重表の危険角度は、それ以下にブームを下げると無負荷でもクレーンが転倒したり、機械の破損につながる角度を示します。
- 8) スーパーラフィングジブを装着したままでブーム作業（通常伸縮）を行う場合は、ブームの定格総荷重表よりつり具の質量の他にブーム長さに応じて下表の荷重を差し引いてください。
なお、スーパーラフィングジブを装着したままでのブーム作業は、ブーム状態が通常伸縮時に限ります。

ブーム長さ	13.6m	18.15m	22.7m	31.8m	40.9m	45.5m	50.0m
差引荷重	25t			18t			

- 9) ルースタシーブの定格総荷重は、ブーム定格総荷重と等しく、かつ、限度を12tonとします。
但し、ブームにつり具等が取り付けられている場合には、定格総荷重よりつり具の質量の他にブームに取り付けられているつり具等の質量も差し引いてください。
- 10) ヘビーリフトジブ31mの単索時定格総荷重は、ヘビーリフトジブ31mの定格総荷重と等しく、かつ、限度を12tonとします。
- 11) ヘビーリフトジブの起伏用ロープは、6本掛にしてください。

12) 作業状態別標準フックの種類・掛数・質量を次に示します。

なお、下表12tonフック使用にあたり、ヘビーリフトジブ作業時にはサブウエイト有（530kg）ブーム作業（ルースタシブ）・スーパーラフィングジブ作業時にはサブウエイト無（420kg）のフックを使用してください。

フック種類	300t	150t	83t	24t	12t	
フック質量	3720kg	1860kg	1000kg	880kg	サブウエイト無/有	
					420kg	530kg

ブーム【通常伸縮】

ブーム長さ	13.6m重荷重	13.6m	18.15m	22.7m	31.8m	40.9m	45.5m	50.0m
フック種類	300t	150t	150t	150t	83t	83t	83t	83t
掛数	28	14	12	12	7	6	4	4

ブーム【特殊伸縮】

ブーム長さ	13.6m	22.7m	31.8m	40.9m
フック種類	150t	83t	83t	83t
掛数	14	7	6	4

ルースタシブ

フック種類	12t
掛数	1

スーパーラフィングジブ

SL長さ	10.0m	15.0m	19.0m	23.0m	27.0m	31.0m
フック種類	24t	12t	12t	12t	12t	12t
掛数	2	1	1	1	1	1

ヘビーリフトジブ

ブーム長さ	HL長さ	13.0m	22.0m	31.0m	40.0m	47.0m	54.0m
13.6m	フック種類	150t	83t	83t (12t)	12t	12t	12t
	掛数	8	6	4 (1)	1	1	1
18.15m	フック種類	150t	83t	83t (12t)	12t	12t	12t
	掛数	8	6	4 (1)	1	1	1
22.7m	フック種類	83t	83t	83t (12t)	12t	12t	12t
	掛数	6	4	4 (1)	1	1	1
31.8m	フック種類	83t	83t	24t (12t)	12t	12t	12t
	掛数	4	4	2 (1)	1	1	1
40.9m	フック種類	—	24t	24t (12t)	12t	12t	12t
	掛数	—	2	2 (1)	1	1	1
45.5m	フック種類	—	24t	24t (12t)	12t	12t	12t
	掛数	—	2	2 (1)	1	1	1
50.0m	フック種類	—	24t	24t (12t)	12t	12t	12t
	掛数	—	2	2 (1)	1	1	1

13) クレーン作業は風速10m/sまで可能ですが、比較的弱い風の場合でも受風面積の大きいつり荷を取扱う場合は特別な注意を払ってください。

14) 定格総荷重表以外の仕事を行った場合および正しい使い方をしなかった時は、転倒又は破損します。この場合は本機の保証はいたしません。

15) 本仕様は改良等により予告なく変更することがあります。

メインブーム(アウトリガ5.4m)

作業半径 (m)	13.6mブーム				18.15mブーム				22.7mブーム				31.8mブーム			
	性能区分				性能区分				性能区分				性能区分			
	C5	D5	E5	F5	C5	D5	E5	F5	C5	D5	E5	F5	C5	D5	E5	F5
3.0	150.0	150.0	150.0	150.0												
3.5	150.0	150.0	150.0	150.0	120.0	120.0	120.0	120.0								
4.0	150.0	150.0	150.0	121.0	120.0	120.0	120.0	104.6	120.0	120.0	118.9	89.4				
4.5	150.0	145.3	109.6	84.6	120.0	120.0	106.9	81.9	120.0	120.0	95.8	71.3				
5.0	140.1	114.2	83.6	64.1	120.0	111.8	81.3	61.8	120.0	110.1	79.4	58.4	70.0	70.0	70.0	53.2
6.0	97.8	76.6	55.3	41.7	95.9	74.6	53.4	39.7	94.5	73.2	51.9	38.3	70.0	70.0	53.9	39.2
7.0	72.8	56.5	40.1	29.7	71.1	54.8	38.4	28.0	69.8	53.5	37.2	26.7	70.0	56.2	39.8	29.4
8.0	57.2	44.0	30.7	22.2	55.6	42.4	29.1	20.6	54.5	41.2	28.0	19.5	56.9	43.6	30.4	21.9
9.0	46.6	35.4	24.3	17.1	45.1	33.9	22.8	15.6	44.0	32.8	21.7	14.6	46.3	35.1	24.0	16.8
10.0	38.9	29.3	19.6	13.5	37.4	27.8	18.2	12.0	36.4	26.8	17.1	11.0	38.5	28.9	19.3	13.1
11.0	33.1	24.6	16.1	10.7	31.6	23.2	14.7	9.3	30.6	22.2	13.7	8.3	32.7	24.2	15.8	10.3
12.0					27.1	19.5	12.0	7.1	26.1	18.5	11.0	6.2	28.1	20.5	13.0	8.1
14.0					20.4	14.2	8.0		19.5	13.2	7.0		21.3	15.1	8.9	
16.0					15.8	10.5			14.8	9.6			16.6	11.3	6.1	
18.0									11.5	6.9			13.1	8.5	3.6	
20.0									8.9				10.5	6.4		
22.0													8.4	4.6		
24.0													6.7			
26.0													5.3			
28.0													3.8			
30.0																
32.0																
34.0																
36.0																
38.0																
40.0																
42.0																
44.0																
46.0																
掛数	14	14	14	14	12	12	12	12	12	12	12	12	7	7	7	7
危険角度(°)	-	-	-	-	-	-	-	34	-	12	41	53	5	35	51	62
フック種類	150t	150t	150t	150t	150t	150t	150t	150t	150t	150t	150t	150t	83t	83t	83t	83t
フック質量(t)	1.86	1.86	1.86	1.86	1.86	1.86	1.86	1.86	1.86	1.86	1.86	1.86	1.0	1.0	1.0	1.0

(単位 : ton)

メインブーム(アウトリガ5.4m)

作業半径 (m)	40.9mブーム				45.5mブーム				50.0mブーム			
	性能区分				性能区分				性能区分			
	C5	D5	E5	F5	C5	D5	E5	F5	C5	D5	E5	F5
3.0												
3.5												
4.0												
4.5												
5.0												
6.0												
7.0	60.0	56.9	39.3	28.0								
8.0	58.0	44.7	31.5	22.3	47.0	45.0	30.9	21.5	35.0	35.0	30.3	21.2
9.0	47.3	36.1	25.0	17.8	47.0	36.4	25.3	17.3	35.0	35.0	25.4	17.2
10.0	39.5	29.9	20.3	14.1	39.8	30.2	20.5	14.0	35.0	30.7	21.1	14.0
11.0	33.6	25.2	16.7	11.3	33.9	25.4	16.9	11.3	34.4	25.9	17.5	11.5
12.0	29.0	21.4	13.9	9.0	29.2	21.7	14.1	9.1	29.7	22.2	14.6	9.3
14.0	22.2	16.0	9.8		22.4	16.2	10.0		22.9	16.7	10.4	
16.0	17.4	12.2	6.9		17.7	12.4	7.1		18.1	12.8	7.5	
18.0	13.9	9.3			14.2	9.6			14.6	10.0		
20.0	11.2	7.2			11.5	7.4			11.9	7.8		
22.0	9.1	5.5			9.3	5.7			9.7	6.1		
24.0	7.4	3.9			7.6	4.2			8.0	4.7		
26.0	6.0				6.2				6.5			
28.0	4.8				5.0				5.3			
30.0	3.4				3.7				4.2			
32.0												
34.0												
36.0												
38.0												
40.0												
42.0												
44.0												
46.0												
掛数	6	6	6	6	4	4	4	4	4	4	4	4
危険角度(°)	35	48	62	70	42	52	65	72	46	57	68	74
フック種類	83t	83t	83t	83t	83t	83t	83t	83t	83t	83t	83t	83t
フック質量(t)	1.0	1.0	1.0	1.0	1.0	1.0	1.0	1.0	1.0	1.0	1.0	1.0

(単位 : ton)

メインブーム(アウトリガ5.4m)

作業半径 (m)	22.7mブーム				31.8mブーム				40.9mブーム			
	性能区分				性能区分				性能区分			
	TC5	TD5	TE5	TF5	TC5	TD5	TE5	TF5	TC5	TD5	TE5	TF5
3.0												
3.5												
4.0	70.0	70.0	70.0	70.0								
4.5	70.0	70.0	70.0	70.0								
5.0	70.0	70.0	70.0	67.8	60.0	60.0	59.2	44.9				
6.0	70.0	70.0	58.3	44.7	60.0	60.0	59.2	44.9				
7.0	70.0	59.1	42.8	32.3	60.0	59.9	43.6	33.1	35.0	35.0	34.4	25.9
8.0	59.6	46.4	33.1	24.6	60.0	47.1	33.8	25.4	35.0	35.0	34.4	25.9
9.0	48.8	37.7	26.5	19.4	49.5	38.3	27.2	20.1	35.0	35.0	27.7	20.6
10.0	41.0	31.4	21.7	15.6	41.6	32.0	22.4	16.2	35.0	32.5	22.9	16.7
11.0	35.0	26.6	18.1	12.7	35.6	27.2	18.7	13.3	35.0	27.6	19.2	13.8
12.0	30.4	22.8	15.3	10.4	31.0	23.4	15.9	11.0	31.4	23.8	16.3	11.5
14.0	23.5	17.3	11.1	7.1	24.1	17.9	11.6	7.7	24.5	18.3	12.0	8.1
16.0	18.7	13.5	8.2	4.8	19.3	14.0	8.7	5.3	19.6	14.4	9.1	5.7
18.0	15.2	10.7	6.1		15.7	11.1	6.5	3.5	16.1	11.5	6.9	
20.0	12.6	8.5	4.5		13.0	8.9	4.9		13.3	9.3	5.2	
22.0					10.9	7.2	3.5		11.2	7.5	3.9	
24.0					9.1	5.8			9.4	6.1		
26.0					7.7	4.7			8.0	4.9		
28.0					6.5	3.7			6.7	4.0		
30.0									5.7			
32.0									4.8			
34.0									4.1			
36.0									3.2			
38.0												
40.0												
42.0												
44.0												
46.0												
48.0												
掛数	7	7	7	7	6	6	6	6	4	4	4	4
危険角度(°)	-	-	-	28	-	-	38	50	9	36	51	62
フック種類	83t	83t	83t	83t	83t	83t	83t	83t	83t	83t	83t	83t
フック質量(t)	1.0	1.0	1.0	1.0	1.0	1.0	1.0	1.0	1.0	1.0	1.0	1.0

(単位 : ton)

AA性能

C/W 80t O/R 7.4m

メインブーム (重荷重装置付)

作業半径 (m)	13.6mブーム						
2.5	*300.0						
3.0	230.0						
3.5	210.0						
4.0	190.0						
4.5	175.0						
5.0	162.0						
6.0							
7.0							
8.0							
9.0							
10.0							
11.0							
12.0							
14.0							
16.0							
18.0							
20.0							
掛数	28						
危険角度 (°)	-						
フック種類	300t						
フック質量 (t)	3.72						

注) *印性能は後方のみ
他は全周同一性能

SA性能

40.9mブーム+2m+10mスーパーラフィングジブ

オフセット 作業半径 (m)	5°		15°		30°		45°		60°	
	ブーム角 (°)	荷重 (ton)	ブーム角 (°)	荷重 (ton)	ブーム角 (°)	荷重 (ton)	ブーム角 (°)	荷重 (ton)	ブーム角 (°)	荷重 (ton)
10.0	79.0	24.0								
11.0	78.1	24.0	79.8	24.0						
12.0	77.1	24.0	78.8	24.0						
14.0	75.1	24.0	76.8	24.0	79.1	24.0				
16.0	73.0	24.0	74.7	24.0	77.0	24.0	78.5	21.4	79.6	19.9
18.0	71.0	24.0	72.7	24.0	74.8	23.3	76.2	20.6	77.1	19.4
20.0	68.9	24.0	70.6	24.0	72.6	22.3	73.9	20.0	74.6	19.1
22.0	66.7	24.0	68.4	23.4	70.2	20.7	71.4	19.0	72.1	18.3
24.0	64.5	23.3	66.0	21.6	67.7	19.3	68.9	17.9	69.4	17.4
26.0	62.0	20.8	63.5	20.0	65.2	18.1	66.3	17.0	66.6	16.6
28.0	59.3	17.9	60.9	18.3	62.6	16.9	63.6	16.1	63.7	15.9
30.0	56.6	15.3	58.2	16.0	59.9	15.9	60.8	15.3		
32.0	53.8	13.1	55.3	13.7	57.0	14.3	57.8	14.5		
34.0	50.9	11.2	52.4	11.7	53.9	12.2	54.5	12.5		
36.0	47.7	9.4	49.2	9.9	50.6	10.3	51.0	10.5		
38.0	44.5	7.9	45.9	8.3	47.2	8.6	47.3	8.7		
40.0	41.0	6.5	42.3	6.8	43.4	7.1				
42.0	37.2	5.2	38.5	5.5	39.3	5.7				
44.0	33.1	4.1	34.1	4.3	34.6	4.4				
46.0	28.3	3.0	29.2	3.2						
掛数		2		2		2		2		2
危険角度(°)		21		21		30		45		60
フック種類		24t		24t		24t		24t		24t
フック質量(t)		0.88		0.88		0.88		0.88		0.88

SA性能

45.5mブーム+2m+10mスーパーラフィングジブ

オフセット 作業半径 (m)	5°		15°		30°		45°		60°	
	ブーム角 (°)	荷重 (ton)	ブーム角 (°)	荷重 (ton)	ブーム角 (°)	荷重 (ton)	ブーム角 (°)	荷重 (ton)	ブーム角 (°)	荷重 (ton)
11.0	79.4	24.0								
12.0	78.5	24.0								
14.0	76.8	24.0	78.3	24.0						
16.0	75.0	24.0	76.6	24.0	78.6	24.0				
18.0	73.2	24.0	74.8	24.0	76.6	22.1	78.0	19.8	78.8	18.6
20.0	71.4	24.0	72.9	23.4	74.5	20.4	75.8	18.5	76.5	17.5
22.0	69.4	22.2	70.7	20.9	72.4	18.9	73.7	17.3	74.3	16.5
24.0	67.2	19.8	68.6	18.8	70.3	17.5	71.4	16.2	71.9	15.6
26.0	65.0	17.8	66.4	17.0	68.1	16.1	69.1	15.3	69.6	14.8
28.0	62.8	16.1	64.1	15.4	65.7	14.7	66.7	14.2	67.1	14.1
30.0	60.5	14.6	61.8	14.0	63.3	13.4	64.2	13.1	64.5	13.0
32.0	58.1	13.0	59.4	12.8	60.9	12.3	61.7	12.1		
34.0	55.5	11.1	56.9	11.6	58.4	11.3	59.1	11.1		
36.0	52.8	9.3	54.2	9.8	55.7	10.4	56.3	10.3		
38.0	50.0	7.8	51.4	8.2	52.8	8.7	53.3	8.9		
40.0	47.2	6.4	48.5	6.8	49.7	7.2	50.0	7.3		
42.0	44.2	5.1	45.3	5.5	46.4	5.8				
44.0	40.8	4.0	42.1	4.3	43.0	4.5				
46.0	37.4	2.9	38.4	3.2	39.1	3.4				
掛数		2		2		2		2		2
危険角度(°)		32		32		32		45		60
フック種類		24t		24t		24t		24t		24t
フック質量(t)		0.88		0.88		0.88		0.88		0.88

SA性能

50.0mブーム+2m+10mスーパーラフィングジブ

オフセット 作業半径 (m)	5°		15°		30°		45°		60°	
	ブーム角 (°)	荷重 (ton)	ブーム角 (°)	荷重 (ton)	ブーム角 (°)	荷重 (ton)	ブーム角 (°)	荷重 (ton)	ブーム角 (°)	荷重 (ton)
12.0	79.5	20.0								
14.0	77.9	20.0	79.4	20.0						
16.0	76.4	20.0	77.8	20.0	79.7	20.0				
18.0	74.7	20.0	76.2	20.0	78.0	20.0	79.4	19.6		
20.0	73.2	20.0	74.6	20.0	76.3	19.6	77.5	18.0	78.2	17.1
22.0	71.6	20.0	72.9	19.5	74.5	17.9	75.6	16.6	76.2	15.9
24.0	69.6	18.4	70.9	17.5	72.5	16.4	73.5	15.3	74.0	14.8
26.0	67.7	16.4	68.9	15.7	70.5	14.9	71.5	14.2	72.0	13.8
28.0	65.6	14.7	66.9	14.2	68.4	13.5	69.4	13.1	69.7	12.9
30.0	63.6	13.3	64.8	12.8	66.3	12.3	67.2	12.0	67.4	11.9
32.0	61.5	11.9	62.7	11.6	64.1	11.2	65.0	11.0	65.1	10.9
34.0	59.3	10.7	60.5	10.5	61.8	10.2	62.7	10.1		
36.0	57.0	9.3	58.2	9.6	59.5	9.3	60.3	9.2		
38.0	54.5	7.7	55.8	8.2	57.2	8.5	57.8	8.5		
40.0	52.1	6.3	53.3	6.7	54.6	7.2	55.1	7.4		
42.0	49.4	5.0	50.6	5.4	51.8	5.8	52.1	6.0		
44.0	46.7	3.9	47.9	4.2	49.0	4.6	49.1	4.7		
46.0	43.7	2.8	44.9	3.1	45.8	3.4				
掛数		2		2		2		2		2
危険角度(°)		40		40		40		45		60
フック種類		24t		24t		24t		24t		24t
フック質量(t)		0.88		0.88		0.88		0.88		0.88

SA性能
40.9mブーム+2m+15mスーパーラフィングジブ

オフセット	5°		15°		30°		45°		60°	
作業半径 (m)	ブーム角 (°)	荷重 (ton)	ブーム角 (°)	荷重 (ton)	ブーム角 (°)	荷重 (ton)	ブーム角 (°)	荷重 (ton)	ブーム角 (°)	荷重 (ton)
11.0	79.3	12.0								
12.0	78.3	12.0								
14.0	76.5	12.0	78.9	12.0						
16.0	74.6	12.0	77.0	12.0						
18.0	72.7	12.0	75.1	12.0	78.3	12.0				
20.0	70.8	12.0	73.2	12.0	76.3	12.0	78.8	12.0		
22.0	68.8	12.0	71.2	12.0	74.3	12.0	76.7	12.0	78.2	12.0
24.0	66.8	12.0	69.2	12.0	72.2	12.0	74.4	12.0	75.9	12.0
26.0	64.8	12.0	67.1	12.0	70.0	12.0	72.2	12.0	73.4	12.0
28.0	62.7	12.0	64.9	12.0	67.8	12.0	69.9	12.0	70.9	12.0
30.0	60.6	12.0	62.8	12.0	65.5	12.0	67.4	12.0	68.2	11.9
32.0	58.4	12.0	60.5	12.0	63.2	12.0	64.8	11.7	65.4	11.4
34.0	56.1	12.0	58.2	12.0	60.7	11.8	62.2	11.1	62.5	11.0
36.0	53.6	11.3	55.8	12.0	58.1	11.2	59.4	10.6		
38.0	50.9	9.7	53.0	10.4	55.4	10.6	56.4	10.2		
40.0	48.1	8.3	50.2	8.9	52.4	9.6	53.2	9.8		
42.0	45.0	7.0	47.1	7.5	49.1	8.1	49.6	8.3		
44.0	41.9	5.9	43.8	6.3	45.6	6.8				
46.0	38.4	4.8	40.3	5.2	41.8	5.5				
48.0	34.7	3.8	36.4	4.1	37.6	4.4				
50.0	30.5	2.9	32.0	3.2	32.7	3.3				
52.0	25.6	2.1	26.9	2.2						
54.0	19.3	1.3	19.9	1.4						
掛数	1		1		1		1		1	
危険角度(°)	17		17		30		45		60	
フック種類	12t		12t		12t		12t		12t	
フック質量(t)	0.42		0.42		0.42		0.42		0.42	

SA性能
45.5mブーム+2m+15mスーパーラフィングジブ

オフセット	5°		15°		30°		45°		60°	
作業半径 (m)	ブーム角 (°)	荷重 (ton)	ブーム角 (°)	荷重 (ton)	ブーム角 (°)	荷重 (ton)	ブーム角 (°)	荷重 (ton)	ブーム角 (°)	荷重 (ton)
14.0	77.8	12.0								
16.0	76.1	12.0	78.4	12.0						
18.0	74.4	12.0	76.6	12.0						
20.0	72.8	12.0	74.9	12.0	77.8	12.0				
22.0	71.0	12.0	73.2	12.0	76.0	12.0	78.2	12.0		
24.0	69.3	12.0	71.4	12.0	74.2	12.0	76.2	12.0	77.6	12.0
26.0	67.5	12.0	69.5	12.0	72.2	12.0	74.2	12.0	75.4	11.7
28.0	65.6	12.0	67.7	12.0	70.3	12.0	72.2	11.7	73.1	11.2
30.0	63.8	12.0	65.8	12.0	68.4	12.0	70.0	11.1	70.9	10.7
32.0	61.8	12.0	63.8	12.0	66.3	11.3	67.7	10.5	68.4	10.2
34.0	59.8	11.7	61.7	11.2	64.1	10.6	65.5	10.0	65.9	9.7
36.0	57.6	10.7	59.5	10.3	61.7	9.9	63.1	9.5	63.3	9.4
38.0	55.3	9.6	57.2	9.5	59.3	9.1	60.6	9.0		
40.0	52.8	8.1	54.8	8.7	56.9	8.5	57.9	8.3		
42.0	50.2	6.9	52.2	7.4	54.2	7.8	55.1	7.7		
44.0	47.5	5.7	49.4	6.2	51.4	6.8	52.1	7.0		
46.0	44.7	4.6	46.5	5.1	48.3	5.6	48.7	5.7		
48.0	41.7	3.6	43.5	4.0	45.0	4.4				
50.0	38.5	2.7	40.2	3.1	41.6	3.4				
52.0	35.0	1.9	36.6	2.2	37.6	2.4				
54.0			32.6	1.4						
掛数	1		1		1		1		1	
危険角度(°)	29		29		30		45		60	
フック種類	12t		12t		12t		12t		12t	
フック質量(t)	0.42		0.42		0.42		0.42		0.42	

SA性能
50.0mブーム+2m+15mスーパーラフィングジブ

オフセット	5°		15°		30°		45°		60°	
作業半径 (m)	ブーム角 (°)	荷重 (ton)	ブーム角 (°)	荷重 (ton)	ブーム角 (°)	荷重 (ton)	ブーム角 (°)	荷重 (ton)	ブーム角 (°)	荷重 (ton)
14.0	78.9	12.0								
16.0	77.4	12.0	79.4	12.0						
18.0	76.0	12.0	78.0	12.0						
20.0	74.5	12.0	76.4	12.0	79.1	12.0				
22.0	72.9	12.0	74.9	12.0	77.5	12.0	79.6	12.0		
24.0	71.3	12.0	73.3	12.0	75.9	12.0	77.8	12.0	79.1	12.0
26.0	69.7	12.0	71.7	12.0	74.2	12.0	76.1	12.0	77.1	11.5
28.0	68.1	12.0	70.0	12.0	72.6	12.0	74.3	11.4	75.2	10.9
30.0	66.5	12.0	68.4	12.0	70.7	11.4	72.3	10.6	73.1	10.2
32.0	64.8	11.8	66.6	11.3	68.7	10.6	70.3	9.9	70.9	9.6
34.0	62.8	10.7	64.6	10.3	66.7	9.8	68.2	9.3	68.7	9.1
36.0	60.9	9.7	62.6	9.4	64.7	9.1	66.0	8.7	66.5	8.6
38.0	58.9	8.8	60.6	8.6	62.6	8.3	63.9	8.2	64.1	8.1
40.0	56.7	8.0	58.5	7.9	60.5	7.6	61.5	7.5		
42.0	54.5	6.7	56.3	7.2	58.2	7.0	59.2	6.9		
44.0	52.1	5.5	53.9	6.1	55.8	6.4	56.7	6.4		
46.0	49.7	4.5	51.4	5.0	53.3	5.6	54.1	5.9		
48.0	47.1	3.5	48.9	4.0	50.6	4.5	51.1	4.7		
50.0	44.5	2.6	46.1	3.0	47.7	3.4				
52.0	41.6	1.8	43.2	2.1	44.6	2.5				
54.0			40.1	1.3	41.2	1.6				
掛数	1		1		1		1		1	
危険角度(°)	38		38		38		45		60	
フック種類	12t		12t		12t		12t		12t	
フック質量(t)	0.42		0.42		0.42		0.42		0.42	

SA性能
40.9mブーム+2m+19mスーパーラフィングジブ

オフセット	5°		15°		30°		45°		60°	
作業半径 (m)	ブーム角 (°)	荷重 (ton)	ブーム角 (°)	荷重 (ton)	ブーム角 (°)	荷重 (ton)	ブーム角 (°)	荷重 (ton)	ブーム角 (°)	荷重 (ton)
12.0	79.5	12.0								
14.0	77.8	12.0								
16.0	76.1	12.0	79.0	12.0						
18.0	74.4	12.0	77.3	12.0						
20.0	72.7	12.0	75.5	12.0	79.4	12.0				
22.0	70.9	12.0	73.7	12.0	77.4	12.0				
24.0	69.1	12.0	71.8	12.0	75.5	12.0	78.4	10.4		
26.0	67.2	12.0	69.9	12.0	73.6	11.6	76.2	10.2	78.0	9.1
28.0	65.3	12.0	68.0	12.0	71.5	11.1	74.0	9.9	75.7	9.0
30.0	63.4	12.0	66.0	11.4	69.4	10.7	71.8	9.7	73.2	8.9
32.0	61.3	11.4	63.8	10.9	67.2	10.3	69.5	9.4	70.7	8.8
34.0	59.2	10.7	61.7	10.4	64.9	10.0	67.1	9.2	68.0	8.8
36.0	56.9	10.2	59.5	10.0	62.6	9.6	64.6	9.0	65.3	8.8
38.0	54.7	9.6	57.2	9.6	60.2	9.2	62.0	8.7	62.3	8.6
40.0	52.3	9.1	54.8	9.2	57.6	8.8	59.2	8.4		
42.0	49.6	8.1	52.2	8.8	54.9	8.4	56.2	8.0		
44.0	46.9	6.9	49.5	7.6	52.1	8.0	53.2	7.7		
46.0	44.0	5.9	46.5	6.4	49.0	7.1	49.7	7.3		
48.0	41.0	4.9	43.3	5.4	45.5	5.9				
50.0	37.6	4.0	39.9	4.4	41.8	4.8				
52.0	34.0	3.1	36.1	3.5	37.5	3.8				
54.0	30.0	2.4	31.8	2.6	32.7	2.8				
56.0	25.1	1.6	26.7	1.8						
掛数	1		1		1		1		1	
危険角度(°)	19		19		30		45		60	
フック種類	12t		12t		12t		12t		12t	
フック質量(t)	0.42		0.42		0.42		0.42		0.42	

SA性能
45.5mブーム+2m+19mスーパーラフィングジブ

オフセット	5°		15°		30°		45°		60°	
作業半径 (m)	ブーム角 (°)	荷重 (ton)	ブーム角 (°)	荷重 (ton)	ブーム角 (°)	荷重 (ton)	ブーム角 (°)	荷重 (ton)	ブーム角 (°)	荷重 (ton)
14.0	79.0	12.0								
16.0	77.4	12.0								
18.0	75.9	12.0	78.5	12.0						
20.0	74.3	12.0	77.0	12.0						
22.0	72.8	12.0	75.3	12.0	78.9	12.0				
24.0	71.1	12.0	73.7	12.0	77.1	12.0	79.7	10.6		
26.0	69.5	12.0	72.1	12.0	75.4	11.9	77.9	10.3	79.5	9.2
28.0	67.8	12.0	70.3	12.0	73.5	11.2	76.0	10.1	77.4	9.1
30.0	66.1	12.0	68.7	12.0	71.6	10.5	74.0	9.6	75.3	9.0
32.0	64.4	12.0	66.8	11.2	69.6	9.9	71.9	9.1	73.0	8.6
34.0	62.5	11.2	64.8	10.5	67.6	9.3	69.7	8.6	70.7	8.3
36.0	60.4	10.2	62.7	9.8	65.5	8.8	67.5	8.2	68.3	7.9
38.0	58.4	9.4	60.7	9.0	63.4	8.3	65.2	7.8	65.8	7.6
40.0	56.3	8.6	58.5	8.3	61.2	7.9	62.8	7.4	63.2	7.3
42.0	54.0	7.9	56.3	7.7	58.9	7.4	60.4	7.1		
44.0	51.6	6.7	54.0	7.1	56.5	6.9	57.8	6.8		
46.0	49.2	5.6	51.5	6.3	53.9	6.4	55.0	6.3		
48.0	46.5	4.7	48.8	5.2	51.2	5.9	52.1	5.9		
50.0	43.7	3.7	46.0	4.3	48.2	4.8	48.7	5.0		
52.0	40.9	2.9	43.0	3.4	45.0	3.8				
54.0	37.7	2.1	39.8	2.5	41.5	2.9				
56.0	34.4	1.4	36.3	1.7	37.6	2.0				
掛数	1		1		1		1		1	
危険角度(°)	31		31		31		45		60	
フック種類	12t		12t		12t		12t		12t	
フック質量(t)	0.42		0.42		0.42		0.42		0.42	

SA性能
50.0mブーム+2m+19mスーパーラフィングジブ

オフセット	5°		15°		30°		45°		60°	
作業半径 (m)	ブーム角 (°)	荷重 (ton)	ブーム角 (°)	荷重 (ton)	ブーム角 (°)	荷重 (ton)	ブーム角 (°)	荷重 (ton)	ブーム角 (°)	荷重 (ton)
16.0	78.6	12.0								
18.0	77.2	12.0	79.7	12.0						
20.0	75.8	12.0	78.3	12.0						
22.0	74.4	12.0	76.8	12.0	80.2	12.0				
24.0	73.0	12.0	75.4	12.0	78.6	12.0				
26.0	71.6	12.0	73.9	12.0	77.1	11.9	79.3	10.4		
28.0	70.1	12.0	72.5	12.0	75.3	11.0	77.6	10.0	78.9	9.1
30.0	68.6	12.0	70.8	11.5	73.6	10.2	75.7	9.4	77.0	8.9
32.0	66.9	11.3	69.0	10.6	71.8	9.5	73.8	8.8	75.0	8.4
34.0	65.1	10.3	67.2	9.8	69.9	8.9	71.9	8.3	72.9	7.9
36.0	63.2	9.4	65.4	9.0	68.1	8.3	69.9	7.7	70.8	7.5
38.0	61.4	8.5	63.6	8.3	66.2	7.7	67.9	7.3	68.7	7.1
40.0	59.5	7.8	61.7	7.6	64.2	7.2	65.8	6.8	66.4	6.7
42.0	57.5	7.1	59.6	6.9	62.2	6.7	63.7	6.4	64.0	6.4
44.0	55.5	6.5	57.6	6.3	60.1	6.2	61.4	6.1		
46.0	53.3	5.4	55.5	5.8	57.8	5.7	59.1	5.6		
48.0	51.0	4.4	53.3	5.1	55.5	5.2	56.6	5.2		
50.0	48.6	3.5	50.8	4.1	53.2	4.8	53.9	4.8		
52.0	46.2	2.7	48.3	3.2	50.5	3.8	51.1	4.1		
54.0	43.6	1.9	45.6	2.4	47.6	2.9				
56.0			42.8	1.6	44.6	2.0				
掛数	1		1		1		1		1	
危険角度(°)	39		39		39		45		60	
フック種類	12t		12t		12t		12t		12t	
フック質量(t)	0.42		0.42		0.42		0.42		0.42	

SA性能
40.9mブーム+2m+23mスーパーラフィングジブ

オフセット	5°		15°		30°		45°		60°	
作業半径 (m)	ブーム角 (°)	荷重 (ton)	ブーム角 (°)	荷重 (ton)	ブーム角 (°)	荷重 (ton)	ブーム角 (°)	荷重 (ton)	ブーム角 (°)	荷重 (ton)
14.0	79.1	12.0								
16.0	77.5	12.0								
18.0	75.9	12.0	79.2	12.0						
20.0	74.3	12.0	77.6	12.0						
22.0	72.7	12.0	76.0	12.0	80.2	10.4				
24.0	71.0	12.0	74.2	11.5	78.4	10.1				
26.0	69.3	11.9	72.4	10.9	76.5	9.8	79.9	8.1		
28.0	67.5	11.1	70.5	10.3	74.6	9.4	77.8	7.8		
30.0	65.6	10.4	68.6	9.8	72.6	9.0	75.7	7.6	77.9	6.8
32.0	63.7	9.8	66.7	9.3	70.6	8.7	73.6	7.5	75.5	6.7
34.0	61.7	9.2	64.7	8.8	68.6	8.4	71.4	7.3	73.1	6.7
36.0	59.7	8.7	62.7	8.4	66.5	8.1	69.2	7.1	70.5	6.6
38.0	57.6	8.2	60.6	8.1	64.3	7.8	66.8	7.0	67.9	6.6
40.0	55.5	7.8	58.5	7.7	62.0	7.5	64.3	6.9	65.1	6.5
42.0	53.3	7.4	56.2	7.4	59.7	7.3	61.8	6.8	62.2	6.5
44.0	51.0	7.0	53.9	7.1	57.3	7.1	59.1	6.7		
46.0	48.6	6.7	51.5	6.9	54.6	6.8	56.2	6.5		
48.0	45.9	6.3	48.9	6.5	51.9	6.5	53.0	6.3		
50.0	43.1	5.9	46.0	6.1	48.9	6.2	49.6	6.1		
52.0	40.2	5.5	42.9	5.8	45.5	5.9				
54.0	36.9	5.0	39.5	5.4	41.8	5.5				
56.0	33.4	4.5	35.9	4.9	37.6	5.0				
58.0	29.4	3.9	31.7	4.3	32.7	4.4				
60.0	24.9	3.3	26.7	3.7						
掛数	1		1		1		1		1	
危険角度(°)	21		21		30		45		60	
フック種類	12t		12t		12t		12t		12t	
フック質量(t)	0.42		0.42		0.42		0.42		0.42	

SA性能
45.5mブーム+2m+23mスーパーラフィングジブ

オフセット	5°		15°		30°		45°		60°	
作業半径 (m)	ブーム角 (°)	荷重 (ton)	ブーム角 (°)	荷重 (ton)	ブーム角 (°)	荷重 (ton)	ブーム角 (°)	荷重 (ton)	ブーム角 (°)	荷重 (ton)
16.0	78.7	12.0								
18.0	77.2	12.0								
20.0	75.8	12.0	78.9	12.0						
22.0	74.3	12.0	77.4	12.0						
24.0	72.9	12.0	75.9	12.0	79.7	10.2				
26.0	71.4	12.0	74.2	11.3	78.0	9.9				
28.0	69.8	11.8	72.5	10.7	76.3	9.6	79.2	7.9		
30.0	68.1	11.1	70.9	10.2	74.6	9.3	77.4	7.7	79.3	6.9
32.0	66.4	10.4	69.2	9.7	72.7	8.9	75.5	7.6	77.2	6.8
34.0	64.6	9.8	67.4	9.3	70.9	8.4	73.5	7.4	75.1	6.7
36.0	62.9	9.3	65.6	8.9	69.0	7.9	71.6	7.2	72.9	6.6
38.0	61.0	8.8	63.8	8.4	67.0	7.5	69.5	6.9	70.6	6.6
40.0	59.1	8.3	61.7	7.8	65.0	7.1	67.3	6.6	68.3	6.3
42.0	57.1	7.6	59.8	7.4	63.0	6.7	65.0	6.3	65.7	6.1
44.0	55.1	7.0	57.7	6.8	60.7	6.3	62.7	6.0	63.1	5.9
46.0	52.9	6.5	55.5	6.3	58.5	6.0	60.2	5.7		
48.0	50.6	5.9	53.2	5.8	56.2	5.7	57.7	5.5		
50.0	48.2	5.3	50.9	5.3	53.7	5.3	54.9	5.2		
52.0	45.6	4.7	48.3	4.7	51.0	4.9	52.0	4.9		
54.0	42.9	4.0	45.6	4.0	48.2	4.2	48.7	4.4		
56.0	40.2	3.3	42.7	3.3	44.9	3.3				
58.0	37.1	2.6	39.5	2.6	41.5	2.6				
60.0			36.1	1.9	37.6	1.7				
掛数	1		1		1		1		1	
危険角度(°)	33		33		33		45		60	
フック種類	12t		12t		12t		12t		12t	
フック質量(t)	0.42		0.42		0.42		0.42		0.42	

SA性能
50.0mブーム+2m+23mスーパーラフィングジブ

オフセット	5°		15°		30°		45°		60°	
作業半径 (m)	ブーム角 (°)	荷重 (ton)	ブーム角 (°)	荷重 (ton)	ブーム角 (°)	荷重 (ton)	ブーム角 (°)	荷重 (ton)	ブーム角 (°)	荷重 (ton)
16.0	79.6	11.0								
18.0	78.3	11.0								
20.0	77.0	11.0	79.8	11.0						
22.0	75.7	11.0	78.5	11.0						
24.0	74.4	11.0	77.2	11.0						
26.0	73.0	11.0	75.8	11.0	79.3	10.1				
28.0	71.7	11.0	74.4	11.0	77.8	9.8				
30.0	70.3	11.0	72.9	10.6	76.3	9.4	78.8	7.8		
32.0	68.8	10.9	71.3	9.8	74.6	8.7	77.1	7.7	78.7	6.8
34.0	67.2	10.0	69.7	9.1	72.9	8.1	75.4	7.5	76.9	6.7
36.0	65.5	9.1	67.9	8.4	71.1	7.6	73.5	7.0	74.9	6.7
38.0	63.7	8.3	66.2	7.8	69.4	7.1	71.6	6.6	72.8	6.4
40.0	62.0	7.6	64.4	7.2	67.5	6.6	69.7	6.2	70.7	6.0
42.0	60.1	6.9	62.7	6.7	65.6	6.2	67.7	5.8	68.5	5.7
44.0	58.3	6.3	60.8	6.2	63.7	5.8	65.7	5.5	66.3	5.4
46.0	56.5	5.8	58.8	5.7	61.7	5.4	63.5	5.2	63.9	5.1
48.0	54.4	5.3	56.9	5.2	59.7	5.1	61.3	4.9		
50.0	52.3	4.7	54.9	4.8	57.6	4.7	59.0	4.6		
52.0	50.1	4.0	52.7	4.2	55.3	4.3	56.6	4.3		
54.0	47.8	3.3	50.3	3.4	53.0	4.0	53.9	4.0		
56.0	45.3	2.6	47.8	2.6	50.3	3.3	51.1	3.6		
58.0	42.8	1.9	45.2	1.9	47.5	2.4				
60.0					44.6	1.7				
掛数	1		1		1		1		1	
危険角度(°)	40		41		41		45		60	
フック種類	12t		12t		12t		12t		12t	
フック質量(t)	0.42		0.42		0.42		0.42		0.42	

SA性能

40.9mブーム+2m+27mスーパーラフィングジブ

オフセット	5°		15°		30°		45°		60°	
作業半径 (m)	ブーム角 (°)	荷重 (ton)	ブーム角 (°)	荷重 (ton)	ブーム角 (°)	荷重 (ton)	ブーム角 (°)	荷重 (ton)	ブーム角 (°)	荷重 (ton)
14.0	80.3	12.0								
16.0	78.9	12.0								
18.0	77.4	12.0								
20.0	75.9	12.0	79.5	11.2						
22.0	74.4	12.0	77.9	10.7						
24.0	72.8	11.4	76.2	10.2						
26.0	71.1	10.6	74.5	9.6	79.2	7.9				
28.0	69.4	9.9	72.8	9.1	77.4	7.6				
30.0	67.7	9.2	71.1	8.6	75.7	7.4	79.4	6.3		
32.0	65.9	8.6	69.3	8.1	73.8	7.2	77.4	6.1	80.0	5.4
34.0	64.1	8.1	67.5	7.7	71.9	7.0	75.4	6.0	77.7	5.3
36.0	62.2	7.6	65.6	7.4	70.0	6.8	73.3	5.8	75.4	5.2
38.0	60.3	7.2	63.7	7.0	68.0	6.6	71.1	5.7	73.0	5.2
40.0	58.4	6.8	61.8	6.7	65.9	6.4	68.9	5.5	70.4	5.1
42.0	56.4	6.4	59.7	6.4	63.8	6.2	66.6	5.4	67.9	5.1
44.0	54.4	6.1	57.6	6.1	61.6	6.0	64.2	5.3	65.1	5.1
46.0	52.2	5.8	55.4	5.9	59.4	5.8	61.7	5.3	62.1	5.1
48.0	49.9	5.5	53.2	5.7	56.9	5.7	59.0	5.2		
50.0	47.7	5.2	50.9	5.5	54.4	5.5	56.1	5.1		
52.0	45.2	4.9	48.4	5.3	51.7	5.3	53.0	5.1		
54.0	42.4	4.1	45.6	4.7	48.7	5.1	49.6	5.0		
56.0	39.5	3.4	42.6	3.9	45.5	4.5				
58.0	36.3	2.7	39.3	3.2	41.8	3.7				
60.0	32.9	2.1	35.7	2.5	37.7	2.9				
62.0	29.1	1.5	31.5	1.8	32.6	2.1				
掛数	1		1		1		1		1	
危険角度(°)	23		23		30		45		60	
フック種類	12t		12t		12t		12t		12t	
フック質量(t)	0.42		0.42		0.42		0.42		0.42	

SA性能

45.5mブーム+2m+27mスーパーラフィングジブ

オフセット	5°		15°		30°		45°		60°	
作業半径 (m)	ブーム角 (°)	荷重 (ton)	ブーム角 (°)	荷重 (ton)	ブーム角 (°)	荷重 (ton)	ブーム角 (°)	荷重 (ton)	ブーム角 (°)	荷重 (ton)
16.0	79.8	11.0								
18.0	78.4	11.0								
20.0	77.1	11.0	80.5	11.0						
22.0	75.7	11.0	79.2	10.9						
24.0	74.3	11.0	77.6	10.4						
26.0	73.0	11.0	76.2	10.0	80.3	8.0				
28.0	71.5	10.5	74.6	9.4	78.8	7.8				
30.0	69.9	9.8	73.0	8.9	77.1	7.5				
32.0	68.3	9.2	71.4	8.5	75.5	7.3	78.8	6.2		
34.0	66.6	8.6	69.8	8.1	73.8	7.1	76.9	6.0	79.2	5.3
36.0	65.0	8.1	68.1	7.7	72.1	7.0	75.2	5.9	77.1	5.3
38.0	63.3	7.7	66.4	7.4	70.3	6.8	73.3	5.8	75.0	5.2
40.0	61.5	7.3	64.6	7.0	68.5	6.4	71.3	5.6	72.8	5.1
42.0	59.7	6.9	62.8	6.7	66.5	6.1	69.3	5.5	70.6	5.1
44.0	57.9	6.5	60.9	6.4	64.6	5.8	67.2	5.4	68.1	5.1
46.0	56.0	6.2	59.0	6.0	62.6	5.5	64.9	5.1	65.7	5.0
48.0	54.1	5.8	57.1	5.7	60.4	5.2	62.7	4.9	63.0	4.8
50.0	52.0	5.4	54.9	5.2	58.3	4.9	60.2	4.7		
52.0	49.8	4.6	52.7	4.9	56.0	4.7	57.6	4.5		
54.0	47.4	3.8	50.5	4.5	53.6	4.4	55.0	4.3		
56.0	44.9	3.1	47.9	3.7	51.0	4.1	51.9	4.1		
58.0	42.3	2.4	45.2	3.0	48.1	3.6	48.7	3.8		
60.0	39.5	1.8	42.3	2.3	45.0	2.8				
62.0			39.3	1.6	41.5	2.1				
64.0					37.6	1.4				
掛数	1		1		1		1		1	
危険角度(°)	34		35		35		45		60	
フック種類	12t		12t		12t		12t		12t	
フック質量(t)	0.42		0.42		0.42		0.42		0.42	

SA性能

50.0mブーム+2m+27mスーパーラフィングジブ

オフセット	5°		15°		30°		45°		60°	
作業半径 (m)	ブーム角 (°)	荷重 (ton)	ブーム角 (°)	荷重 (ton)	ブーム角 (°)	荷重 (ton)	ブーム角 (°)	荷重 (ton)	ブーム角 (°)	荷重 (ton)
18.0	79.1	9.0								
20.0	77.9	9.0								
22.0	76.7	9.0	79.9	9.0						
24.0	75.4	9.0	78.6	9.0						
26.0	74.1	9.0	77.3	9.0						
28.0	72.9	9.0	76.0	9.0	80.0	7.9				
30.0	71.6	9.0	74.7	9.0	78.5	7.6				
32.0	70.3	9.0	73.3	8.8	77.0	7.4	80.1	6.3		
34.0	68.9	9.0	71.8	8.4	75.5	7.3	78.4	6.1		
36.0	67.4	8.6	70.3	7.9	73.9	7.0	76.8	6.0	78.6	5.3
38.0	65.9	8.0	68.6	7.3	72.3	6.6	75.0	5.8	76.7	5.2
40.0	64.3	7.4	67.0	6.8	70.6	6.2	73.3	5.7	74.8	5.2
42.0	62.5	6.8	65.3	6.3	68.9	5.8	71.5	5.4	72.8	5.1
44.0	60.9	6.2	63.6	5.9	67.1	5.4	69.5	5.1	70.7	4.9
46.0	59.1	5.7	61.9	5.5	65.3	5.1	67.6	4.8	68.5	4.7
48.0	57.3	5.2	60.0	5.1	63.4	4.7	65.6	4.5	66.2	4.4
50.0	55.5	4.8	58.2	4.7	61.4	4.4	63.4	4.2	63.8	4.2
52.0	53.6	4.3	56.2	4.3	59.5	4.2	61.3	4.0		
54.0	51.5	3.5	54.3	3.9	57.3	3.9	59.0	3.8		
56.0	49.3	2.8	52.2	3.5	55.2	3.6	56.5	3.6		
58.0	47.0	2.2	49.8	2.8	52.8	3.3	53.9	3.3		
60.0	44.6	1.5	47.4	2.1	50.3	2.8	51.1	3.0		
62.0			44.9	1.5	47.5	2.0				
64.0					44.5	1.3				
掛数	1		1		1		1		1	
危険角度(°)	42		42		42		45		60	
フック種類	12t		12t		12t		12t		12t	
フック質量(t)	0.42		0.42		0.42		0.42		0.42	

31mスーパーラフィングジブ定格総荷重表

SA性能

40.9mブーム+2m+31mスーパーラフィングジブ

オフセット 作業半径 (m)	5°		15°		30°		45°		60°	
	ブーム角 (°)	荷重 (ton)	ブーム角 (°)	荷重 (ton)	ブーム角 (°)	荷重 (ton)	ブーム角 (°)	荷重 (ton)	ブーム角 (°)	荷重 (ton)
16.0	79.7	9.0								
18.0	78.3	9.0								
20.0	76.9	9.0								
22.0	75.5	9.0	79.6	9.0						
24.0	74.1	9.0	78.1	8.7						
26.0	72.7	9.0	76.5	8.3						
28.0	71.2	8.9	74.9	8.0	80.0	6.4				
30.0	69.6	8.3	73.3	7.6	78.4	6.2				
32.0	67.9	7.8	71.7	7.3	76.7	6.1				
34.0	66.2	7.3	70.0	6.9	74.9	5.9	79.0	4.9		
36.0	64.5	6.8	68.3	6.6	73.2	5.7	77.0	4.8		
38.0	62.8	6.4	66.4	6.2	71.2	5.5	75.1	4.7	77.7	4.2
40.0	61.0	6.1	64.6	5.9	69.4	5.3	73.1	4.6	75.4	4.2
42.0	59.1	5.7	62.8	5.7	67.5	5.1	70.9	4.5	73.0	4.1
44.0	57.2	5.4	60.9	5.4	65.5	5.0	68.8	4.4	70.5	4.1
46.0	55.3	5.1	59.0	5.2	63.4	4.8	66.5	4.3	67.8	4.0
48.0	53.4	4.9	56.9	5.0	61.2	4.7	64.0	4.2	64.9	4.0
50.0	51.2	4.6	54.8	4.8	59.0	4.6	61.6	4.2	62.0	4.0
52.0	49.1	4.4	52.7	4.6	56.6	4.5	58.9	4.1		
54.0	46.9	4.2	50.3	4.4	54.2	4.4	56.1	4.1		
56.0	44.5	4.0	47.9	4.3	51.6	4.3	52.9	4.0		
58.0	41.9	3.5	45.3	4.1	48.7	4.2	49.5	4.0		
60.0	39.0	2.8	42.4	3.4	45.5	4.0				
62.0	35.9	2.2	39.1	2.7	41.9	3.2				
64.0	32.5	1.7	35.5	2.1	37.6	2.5				
66.0			31.5	1.5	32.6	1.7				
72.0										
掛数	1		1		1		1		1	
危険角度(°)	26		26		30		45		60	
フック種類	12t		12t		12t		12t		12t	
フック質量(t)	0.42		0.42		0.42		0.42		0.42	

SA性能

45.5mブーム+2m+31mスーパーラフィングジブ

オフセット 作業半径 (m)	5°		15°		30°		45°		60°	
	ブーム角 (°)	荷重 (ton)	ブーム角 (°)	荷重 (ton)	ブーム角 (°)	荷重 (ton)	ブーム角 (°)	荷重 (ton)	ブーム角 (°)	荷重 (ton)
18.0	79.3	9.0								
20.0	78.0	9.0								
22.0	76.8	9.0	80.6	9.0						
24.0	75.5	9.0	79.3	9.0						
26.0	74.2	9.0	77.8	8.5						
28.0	72.9	9.0	76.4	8.2						
30.0	71.5	8.8	74.9	7.8	79.6	6.3				
32.0	70.0	8.3	73.5	7.5	78.0	6.1				
34.0	68.5	7.7	72.0	7.2	76.4	6.0	80.2	5.0		
36.0	66.9	7.3	70.4	6.8	74.9	5.8	78.5	4.9		
38.0	65.3	6.9	68.8	6.5	73.2	5.6	76.6	4.7	79.1	4.2
40.0	63.7	6.5	67.1	6.2	71.5	5.4	74.8	4.6	77.1	4.2
42.0	62.1	6.1	65.5	6.0	69.8	5.3	72.9	4.5	75.0	4.1
44.0	60.4	5.8	63.8	5.7	68.0	5.1	71.1	4.5	72.7	4.1
46.0	58.7	5.5	62.0	5.5	66.2	5.0	69.1	4.4	70.5	4.0
48.0	56.9	5.2	60.2	5.2	64.3	4.8	67.0	4.3	68.1	4.0
50.0	55.1	5.0	58.4	5.0	62.2	4.5	64.9	4.2	65.6	4.0
52.0	53.2	4.7	56.5	4.7	60.2	4.3	62.6	4.1	62.9	4.0
54.0	51.3	4.5	54.4	4.4	58.0	4.1	60.2	3.9		
56.0	49.0	3.8	52.3	4.1	55.9	3.9	57.6	3.7		
58.0	46.7	3.1	50.1	3.8	53.4	3.7	54.9	3.6		
60.0	44.2	2.5	47.5	3.1	50.9	3.5	51.9	3.4		
62.0	41.7	1.9	44.9	2.5	48.1	3.2	48.6	3.2		
64.0	39.0	1.4	42.1	1.9	45.0	2.4				
66.0			39.1	1.3	41.5	1.8				
掛数	1		1		1		1		1	
危険角度(°)	36		36		36		45		60	
フック種類	12t		12t		12t		12t		12t	
フック質量(t)	0.42		0.42		0.42		0.42		0.42	

SA性能

50.0mブーム+2m+31mスーパーラフィングジブ

オフセット 作業半径 (m)	5°		15°		30°		45°		60°	
	ブーム角 (°)	荷重 (ton)	ブーム角 (°)	荷重 (ton)	ブーム角 (°)	荷重 (ton)	ブーム角 (°)	荷重 (ton)	ブーム角 (°)	荷重 (ton)
18.0	80.0	8.0								
20.0	78.8	8.0								
22.0	77.7	8.0								
24.0	76.6	8.0	80.1	8.0						
26.0	75.4	8.0	78.9	8.0						
28.0	74.1	8.0	77.7	8.0						
30.0	72.9	8.0	76.5	8.0	80.6	6.4				
32.0	71.7	8.0	75.0	7.7	79.3	6.2				
34.0	70.5	8.0	73.7	7.4	77.8	6.1				
36.0	69.2	7.7	72.3	7.1	76.4	5.9	79.7	4.9		
38.0	67.7	7.3	70.9	6.8	74.8	5.7	78.1	4.8		
40.0	66.2	6.9	69.4	6.4	73.4	5.5	76.5	4.7	78.6	4.2
42.0	64.7	6.5	67.8	6.0	71.8	5.4	74.8	4.6	76.7	4.1
44.0	63.2	6.0	66.3	5.6	70.2	5.1	73.1	4.5	74.8	4.1
46.0	61.6	5.6	64.6	5.2	68.4	4.7	71.3	4.4	72.8	4.1
48.0	59.9	5.1	62.9	4.8	66.7	4.4	69.4	4.2	70.7	4.0
50.0	58.2	4.7	61.3	4.5	64.9	4.2	67.5	4.0	68.5	3.9
52.0	56.4	4.3	59.4	4.2	63.1	3.9	65.5	3.7	66.1	3.7
54.0	54.7	3.9	57.7	3.9	61.2	3.7	63.4	3.5		
56.0	52.8	3.5	55.8	3.6	59.3	3.4	61.2	3.3		
58.0	50.7	2.8	53.9	3.3	57.1	3.2	58.9	3.1		
60.0	48.5	2.2	51.8	2.9	55.1	3.0	56.5	2.9		
62.0	46.3	1.6	49.4	2.3	52.7	2.7	53.9	2.8		
64.0			47.1	1.6	50.2	2.4	51.1	2.5		
66.0					47.5	1.7				
掛数	1		1		1		1		1	
危険角度(°)	43		43		43		45		60	
フック種類	12t		12t		12t		12t		12t	
フック質量(t)	0.42		0.42		0.42		0.42		0.42	

SB性能

40.9mブーム+2m+10mスーパーラフィングジブ

オフセット 作業半径 (m)	5°		15°		30°		45°		60°	
	ブーム角 (°)	荷重 (ton)	ブーム角 (°)	荷重 (ton)	ブーム角 (°)	荷重 (ton)	ブーム角 (°)	荷重 (ton)	ブーム角 (°)	荷重 (ton)
10.0	79.0	24.0								
11.0	78.1	24.0	79.8	24.0						
12.0	77.1	24.0	78.8	24.0						
14.0	75.1	24.0	76.8	24.0	79.1	24.0				
16.0	73.0	24.0	74.7	24.0	77.0	24.0	78.5	21.4	79.6	19.9
18.0	71.0	24.0	72.7	24.0	74.8	23.3	76.2	20.6	77.1	19.4
20.0	68.9	24.0	70.6	24.0	72.6	22.3	73.9	20.0	74.6	19.1
22.0	66.7	23.6	68.4	23.4	70.2	20.7	71.4	19.0	72.1	18.3
24.0	64.1	19.9	65.9	20.8	67.7	19.3	68.9	17.9	69.4	17.4
26.0	61.6	16.8	63.2	17.6	65.2	18.1	66.3	17.0	66.6	16.6
28.0	58.9	14.2	60.5	14.9	62.4	15.8	63.6	16.1	63.7	15.9
30.0	56.2	11.9	57.8	12.5	59.6	13.3	60.6	13.8		
32.0	53.4	9.9	54.9	10.4	56.6	11.1	57.4	11.5		
34.0	50.5	8.1	52.0	8.6	53.5	9.2	54.2	9.4		
36.0	47.3	6.5	48.8	7.0	50.3	7.5	50.7	7.6		
38.0	44.1	5.1	45.5	5.5	46.8	5.9				
40.0	40.7	3.9	41.9	4.2	43.1	4.5				
42.0	36.8	2.8	38.1	3.0	38.9	3.2				
掛数	2		2		2		2		2	
危険角度(°)	33		33		33		45		60	
フック種類	24t		24t		24t		24t		24t	
フック質量(t)	0.88		0.88		0.88		0.88		0.88	

SB性能

45.5mブーム+2m+10mスーパーラフィングジブ

オフセット 作業半径 (m)	5°		15°		30°		45°		60°	
	ブーム角 (°)	荷重 (ton)	ブーム角 (°)	荷重 (ton)	ブーム角 (°)	荷重 (ton)	ブーム角 (°)	荷重 (ton)	ブーム角 (°)	荷重 (ton)
11.0	79.4	24.0								
12.0	78.5	24.0								
14.0	76.8	24.0	78.3	24.0						
16.0	75.0	24.0	76.6	24.0	78.6	24.0				
18.0	73.2	24.0	74.8	24.0	76.6	22.1	78.0	19.8	78.8	18.6
20.0	71.4	24.0	72.9	23.4	74.5	20.4	75.8	18.5	76.5	17.5
22.0	69.4	22.2	70.7	20.9	72.4	18.9	73.7	17.3	74.3	16.5
24.0	67.2	19.8	68.6	18.8	70.3	17.5	71.4	16.2	71.9	15.6
26.0	64.9	16.7	66.4	17.0	68.1	16.1	69.1	15.3	69.6	14.8
28.0	62.5	14.1	64.1	14.8	65.7	14.7	66.7	14.2	67.1	14.1
30.0	60.1	11.8	61.6	12.5	63.3	13.3	64.2	13.1	64.5	13.0
32.0	57.6	9.8	59.0	10.4	60.7	11.1	61.6	11.6		
34.0	55.1	8.0	56.5	8.6	58.0	9.2	58.9	9.6		
36.0	52.3	6.5	53.7	6.9	55.3	7.5	55.9	7.8		
38.0	49.6	5.1	51.0	5.5	52.3	6.0	52.8	6.2		
40.0	46.7	3.8	48.0	4.2	49.3	4.6	49.6	4.7		
42.0	43.7	2.7	44.9	3.0	46.0	3.3				
掛数	2		2		2		2		2	
危険角度(°)	41		41		41		45		60	
フック種類	24t		24t		24t		24t		24t	
フック質量(t)	0.88		0.88		0.88		0.88		0.88	

SB性能

50.0mブーム+2m+10mスーパーラフィングジブ

オフセット 作業半径 (m)	5°		15°		30°		45°		60°	
	ブーム角 (°)	荷重 (ton)	ブーム角 (°)	荷重 (ton)	ブーム角 (°)	荷重 (ton)	ブーム角 (°)	荷重 (ton)	ブーム角 (°)	荷重 (ton)
12.0	79.5	20.0								
14.0	77.9	20.0	79.4	20.0						
16.0	76.4	20.0	77.8	20.0						
18.0	74.7	20.0	76.2	20.0	79.7	20.0				
20.0	73.2	20.0	74.6	20.0	78.0	20.0	79.4	19.6		
22.0	71.6	20.0	72.9	19.5	76.3	19.6	77.5	18.0	78.2	17.1
24.0	69.6	18.4	70.9	17.5	74.5	17.9	75.6	16.6	76.2	15.9
26.0	67.7	16.4	68.9	15.7	72.5	16.4	73.5	15.3	74.0	14.8
28.0	65.5	14.0	66.9	14.2	70.5	14.9	71.5	14.2	72.0	13.8
30.0	63.4	11.7	64.7	12.4	68.4	13.5	69.4	13.1	69.7	12.9
32.0	61.1	9.7	62.4	10.4	66.3	12.3	67.2	12.0	67.4	11.9
34.0	58.8	7.9	60.2	8.5	64.0	11.1	65.0	11.0	65.1	10.9
36.0	56.4	6.4	57.7	6.9	61.7	9.2	62.6	9.7		
38.0	54.0	5.0	55.3	5.4	59.2	7.5	60.0	7.9		
40.0	51.5	3.7	52.7	4.1	56.7	6.0	57.3	6.3		
42.0			50.1	3.0	54.1	4.6	54.6	4.8		
					51.3	3.4	51.6	3.5		
掛数	2		2		2		2		2	
危険角度(°)	47		47		47		47		60	
フック種類	24t		24t		24t		24t		24t	
フック質量(t)	0.88		0.88		0.88		0.88		0.88	

SB性能

40.9mブーム+2m+15mスーパーラフィングジブ

オフセット 作業半径 (m)	5°		15°		30°		45°		60°	
	ブーム角 (°)	荷重 (ton)	ブーム角 (°)	荷重 (ton)	ブーム角 (°)	荷重 (ton)	ブーム角 (°)	荷重 (ton)	ブーム角 (°)	荷重 (ton)
11.0	79.3	12.0								
12.0	78.3	12.0								
14.0	76.5	12.0	78.9	12.0						
16.0	74.6	12.0	77.0	12.0						
18.0	72.7	12.0	75.1	12.0	78.3	12.0				
20.0	70.8	12.0	73.2	12.0	76.3	12.0	78.8	12.0		
22.0	68.8	12.0	71.2	12.0	74.3	12.0	76.7	12.0	78.2	12.0
24.0	66.8	12.0	69.2	12.0	72.2	12.0	74.4	12.0	75.9	12.0
26.0	64.8	12.0	67.1	12.0	70.0	12.0	72.2	12.0	73.4	12.0
28.0	62.7	12.0	64.9	12.0	67.8	12.0	69.9	12.0	70.9	12.0
30.0	60.6	12.0	62.8	12.0	65.5	12.0	67.4	12.0	68.2	11.9
32.0	58.4	11.8	60.5	12.0	63.2	12.0	64.8	11.7	65.4	11.4
34.0	55.8	10.0	58.0	10.8	60.7	11.8	62.2	11.1	62.5	11.0
36.0	53.2	8.4	55.4	9.2	57.9	10.0	59.4	10.6		
38.0	50.5	7.0	52.6	7.7	55.0	8.4	56.2	8.9		
40.0	47.6	5.7	49.7	6.3	52.0	7.0	52.9	7.3		
42.0	44.6	4.6	46.7	5.1	48.7	5.6	49.3	5.9		
44.0	41.4	3.5	43.4	3.9	45.2	4.4				
46.0	38.0	2.5	39.9	2.9	41.4	3.3				
48.0	34.3	1.6	36.0	2.0	37.2	2.2				
掛数		1		1		1		1		1
危険角度(°)		30		30		30		45		60
フック種類		12t		12t		12t		12t		12t
フック質量(t)		0.42		0.42		0.42		0.42		0.42

SB性能

45.5mブーム+2m+15mスーパーラフィングジブ

オフセット 作業半径 (m)	5°		15°		30°		45°		60°	
	ブーム角 (°)	荷重 (ton)	ブーム角 (°)	荷重 (ton)	ブーム角 (°)	荷重 (ton)	ブーム角 (°)	荷重 (ton)	ブーム角 (°)	荷重 (ton)
14.0	77.8	12.0								
16.0	76.1	12.0	78.4	12.0						
18.0	74.4	12.0	76.6	12.0						
20.0	72.8	12.0	74.9	12.0	77.8	12.0				
22.0	71.0	12.0	73.2	12.0	76.0	12.0	78.2	12.0		
24.0	69.3	12.0	71.4	12.0	74.2	12.0	76.2	12.0	77.6	12.0
26.0	67.5	12.0	69.5	12.0	72.2	12.0	74.2	12.0	75.4	11.7
28.0	65.6	12.0	67.7	12.0	70.3	12.0	72.2	11.7	73.1	11.2
30.0	63.8	12.0	65.8	12.0	68.4	12.0	70.0	11.1	70.9	10.7
32.0	61.8	11.7	63.8	12.0	66.3	11.3	67.7	10.5	68.4	10.2
34.0	59.5	9.9	61.7	10.7	64.1	10.6	65.5	10.0	65.9	9.7
36.0	57.1	8.3	59.3	9.0	61.7	9.9	63.1	9.5	63.3	9.4
38.0	54.8	6.8	56.8	7.5	59.2	8.4	60.5	9.0		
40.0	52.3	5.5	54.3	6.2	56.6	7.0	57.7	7.4		
42.0	49.7	4.4	51.7	5.0	53.8	5.6	54.8	6.0		
44.0	47.0	3.3	48.9	3.8	50.9	4.4	51.7	4.7		
46.0	44.2	2.4	46.0	2.8	47.8	3.3	48.3	3.5		
48.0	41.2	1.5	43.0	1.9	44.6	2.3				
50.0					41.1	1.3				
掛数		1		1		1		1		1
危険角度(°)		39		39		39		45		60
フック種類		12t		12t		12t		12t		12t
フック質量(t)		0.42		0.42		0.42		0.42		0.42

SB性能

50.0mブーム+2m+15mスーパーラフィングジブ

オフセット 作業半径 (m)	5°		15°		30°		45°		60°	
	ブーム角 (°)	荷重 (ton)	ブーム角 (°)	荷重 (ton)	ブーム角 (°)	荷重 (ton)	ブーム角 (°)	荷重 (ton)	ブーム角 (°)	荷重 (ton)
14.0	78.9	12.0								
16.0	77.4	12.0	79.4	12.0						
18.0	76.0	12.0	78.0	12.0						
20.0	74.5	12.0	76.4	12.0	79.1	12.0				
22.0	72.9	12.0	74.9	12.0	77.5	12.0	79.6	12.0		
24.0	71.3	12.0	73.3	12.0	75.9	12.0	77.8	12.0	79.1	12.0
26.0	69.7	12.0	71.7	12.0	74.2	12.0	76.1	12.0	77.1	11.5
28.0	68.1	12.0	70.0	12.0	72.6	12.0	74.3	11.4	75.2	10.9
30.0	66.5	12.0	68.4	12.0	70.7	11.4	72.3	10.6	73.1	10.2
32.0	64.7	11.5	66.6	11.3	68.7	10.6	70.3	9.9	70.9	9.6
34.0	62.6	9.7	64.6	10.3	66.7	9.8	68.2	9.3	68.7	9.1
36.0	60.6	8.1	62.5	8.9	64.7	9.1	66.0	8.7	66.5	8.6
38.0	58.4	6.7	60.3	7.4	62.6	8.3	63.9	8.2	64.1	8.1
40.0	56.1	5.4	58.1	6.1	60.3	6.9	61.5	7.5		
42.0	53.9	4.2	55.8	4.9	57.8	5.6	59.0	6.1		
44.0	51.5	3.2	53.3	3.7	55.4	4.4	56.3	4.8		
46.0	49.1	2.2	50.8	2.7	52.8	3.3	53.5	3.6		
48.0			48.3	1.8	50.0	2.3	50.5	2.5		
50.0					47.1	1.4				
掛数		1		1		1		1		1
危険角度(°)		45		45		45		45		60
フック種類		12t		12t		12t		12t		12t
フック質量(t)		0.42		0.42		0.42		0.42		0.42

SB性能

40.9mブーム+2m+19mスーパーラフィングジブ

オフセット	5°		15°		30°		45°		60°	
作業半径 (m)	ブーム角 (°)	荷重 (ton)	ブーム角 (°)	荷重 (ton)	ブーム角 (°)	荷重 (ton)	ブーム角 (°)	荷重 (ton)	ブーム角 (°)	荷重 (ton)
12.0	79.5	12.0								
14.0	77.8	12.0								
16.0	76.1	12.0	79.0	12.0						
18.0	74.4	12.0	77.3	12.0						
20.0	72.7	12.0	75.5	12.0	79.4	12.0				
22.0	70.9	12.0	73.7	12.0	77.4	12.0				
24.0	69.1	12.0	71.8	12.0	75.5	12.0	78.4	10.4		
26.0	67.2	12.0	69.9	12.0	73.6	11.6	76.2	10.2	78.0	9.1
28.0	65.3	12.0	68.0	12.0	71.5	11.1	74.0	9.9	75.7	9.0
30.0	63.4	12.0	66.0	11.4	69.4	10.7	71.8	9.7	73.2	8.9
32.0	61.3	11.4	63.8	10.9	67.2	10.3	69.5	9.4	70.7	8.8
34.0	59.2	10.7	61.7	10.4	64.9	10.0	67.1	9.2	68.0	8.8
36.0	56.8	9.5	59.5	10.0	62.6	9.6	64.6	9.0	65.3	8.8
38.0	54.4	8.1	57.0	9.0	60.2	9.2	62.0	8.7	62.3	8.6
40.0	51.8	6.8	54.5	7.6	57.6	8.6	59.2	8.4		
42.0	49.2	5.6	51.8	6.3	54.7	7.2	56.2	7.7		
44.0	46.4	4.6	49.0	5.2	51.7	6.0	52.9	6.4		
46.0	43.5	3.6	46.0	4.2	48.6	4.8	49.3	5.1		
48.0	40.5	2.7	42.8	3.2	45.1	3.7				
50.0	37.1	1.9	39.5	2.3	41.4	2.7				
52.0			35.7	1.5	37.2	1.8				
掛数	1		1		1		1		1	
危険角度(°)	32		32		32		45		60	
フック種類	12t		0.42		0.42		0.42		0.42	
フック質量(t)	0.42				1		1		1	

SB性能

45.5mブーム+2m+19mスーパーラフィングジブ

オフセット	5°		15°		30°		45°		60°	
作業半径 (m)	ブーム角 (°)	荷重 (ton)	ブーム角 (°)	荷重 (ton)	ブーム角 (°)	荷重 (ton)	ブーム角 (°)	荷重 (ton)	ブーム角 (°)	荷重 (ton)
14.0	79.0	12.0								
16.0	77.4	12.0								
18.0	75.9	12.0	78.5	12.0						
20.0	74.3	12.0	77.0	12.0						
22.0	72.8	12.0	75.3	12.0	78.9	12.0				
24.0	71.1	12.0	73.7	12.0	77.1	12.0	79.7	10.6		
26.0	69.5	12.0	72.1	12.0	75.4	11.9	77.9	10.3	79.5	9.2
28.0	67.8	12.0	70.3	12.0	73.5	11.2	76.0	10.1	77.4	9.1
30.0	66.1	12.0	68.7	12.0	71.6	10.5	74.0	9.6	75.3	9.0
32.0	64.4	12.0	66.8	11.2	69.6	9.9	71.9	9.1	73.0	8.6
34.0	62.4	10.9	64.8	10.5	67.6	9.3	69.7	8.6	70.7	8.3
36.0	60.3	9.3	62.7	9.8	65.5	8.8	67.5	8.2	68.3	7.9
38.0	58.1	7.9	60.6	8.8	63.4	8.3	65.2	7.8	65.8	7.6
40.0	55.8	6.6	58.4	7.4	61.2	7.9	62.8	7.4	63.2	7.3
42.0	53.4	5.4	56.0	6.2	58.8	7.1	60.4	7.1		
44.0	51.1	4.4	53.5	5.0	56.2	5.9	57.7	6.4		
46.0	48.6	3.4	50.9	4.0	53.5	4.8	54.8	5.2		
48.0	45.9	2.5	48.2	3.1	50.7	3.7	51.7	4.0		
50.0	43.2	1.7	45.5	2.2	47.7	2.7	48.3	3.0		
52.0			42.5	1.4	44.5	1.8				
掛数	1		1		1		1		1	
危険角度(°)	40		40		40		45		60	
フック種類	12t		12t		12t		12t		12t	
フック質量(t)	0.42		0.42		0.42		0.42		0.42	

SB性能

50.0mブーム+2m+19mスーパーラフィングジブ

オフセット	5°		15°		30°		45°		60°	
作業半径 (m)	ブーム角 (°)	荷重 (ton)	ブーム角 (°)	荷重 (ton)	ブーム角 (°)	荷重 (ton)	ブーム角 (°)	荷重 (ton)	ブーム角 (°)	荷重 (ton)
16.0	78.6	12.0								
18.0	77.2	12.0	79.7	12.0						
20.0	75.8	12.0	78.3	12.0						
22.0	74.4	12.0	76.8	12.0	80.2	12.0				
24.0	73.0	12.0	75.4	12.0	78.6	12.0				
26.0	71.6	12.0	73.9	12.0	77.1	11.9	79.3	10.4		
28.0	70.1	12.0	72.5	12.0	75.3	11.0	77.6	10.0	78.9	9.1
30.0	68.6	12.0	70.8	11.5	73.6	10.2	75.7	9.4	77.0	8.9
32.0	66.9	11.3	69.0	10.6	71.8	9.5	73.8	8.8	75.0	8.4
34.0	65.1	10.3	67.2	9.8	69.9	8.9	71.9	8.3	72.9	7.9
36.0	63.2	9.1	65.4	9.0	68.1	8.3	69.9	7.7	70.8	7.5
38.0	61.2	7.7	63.6	8.3	66.2	7.7	67.9	7.3	68.7	7.1
40.0	59.1	6.4	61.6	7.3	64.2	7.2	65.8	6.8	66.4	6.7
42.0	57.0	5.2	59.4	6.0	62.2	6.7	63.7	6.4	64.0	6.4
44.0	54.9	4.1	57.2	4.9	60.0	5.8	61.4	6.1		
46.0	52.7	3.2	54.9	3.9	57.6	4.7	59.0	5.2		
48.0	50.3	2.3	52.6	2.9	55.1	3.7	56.3	4.1		
50.0	48.0	1.5	50.2	2.0	52.6	2.7	53.5	3.1		
52.0					49.9	1.8	50.6	2.1		
掛数	1		1		1		1		1	
危険角度(°)	46		46		47		47		60	
フック種類	12t		12t		12t		12t		12t	
フック質量(t)	0.42		0.42		0.42		0.42		0.42	

SB性能

40.9mブーム+2m+23mスーパーラフィングジブ

オフセット 作業半径 (m)	5°		15°		30°		45°		60°	
	ブーム角 (°)	荷重 (ton)	ブーム角 (°)	荷重 (ton)	ブーム角 (°)	荷重 (ton)	ブーム角 (°)	荷重 (ton)	ブーム角 (°)	荷重 (ton)
14.0	79.1	12.0								
16.0	77.5	12.0								
18.0	75.9	12.0	79.2	12.0						
20.0	74.3	12.0	77.6	12.0						
22.0	72.7	12.0	76.0	12.0	80.2	10.4				
24.0	71.0	12.0	74.2	11.5	78.4	10.1				
26.0	69.3	11.9	72.4	10.9	76.5	9.8	79.9	8.1		
28.0	67.5	11.1	70.5	10.3	74.6	9.4	77.8	7.8		
30.0	65.6	10.4	68.6	9.8	72.6	9.0	75.7	7.6	77.9	6.8
32.0	63.7	9.8	66.7	9.3	70.6	8.7	73.6	7.5	75.5	6.7
34.0	61.7	9.2	64.7	8.8	68.6	8.4	71.4	7.3	73.1	6.7
36.0	59.7	8.7	62.7	8.4	66.5	8.1	69.2	7.1	70.5	6.6
38.0	57.6	8.2	60.6	8.1	64.3	7.8	66.8	7.0	67.9	6.6
40.0	55.5	7.8	58.5	7.7	62.0	7.5	64.3	6.9	65.1	6.5
42.0	53.1	6.6	56.2	7.4	59.7	7.3	61.8	6.8	62.2	6.5
44.0	50.6	5.5	53.7	6.3	57.3	7.1	59.1	6.7		
46.0	48.1	4.6	51.1	5.3	54.5	6.2	56.2	6.5		
48.0	45.4	3.7	48.4	4.3	51.6	5.1	52.9	5.6		
50.0	42.6	2.8	45.5	3.4	48.4	4.1	49.3	4.4		
52.0	39.6	2.1	42.4	2.6	45.1	3.2				
54.0	36.4	1.4	39.0	1.8	41.4	2.3				
56.0					37.2	1.4				
掛数	1		1		1		1		1	
危険角度(°)	34		34		34		45		60	
フック種類	12t		12t		12t		12t		12t	
フック質量(t)	0.42		0.42		0.42		0.42		0.42	

SB性能

45.5mブーム+2m+23mスーパーラフィングジブ

オフセット 作業半径 (m)	5°		15°		30°		45°		60°	
	ブーム角 (°)	荷重 (ton)	ブーム角 (°)	荷重 (ton)	ブーム角 (°)	荷重 (ton)	ブーム角 (°)	荷重 (ton)	ブーム角 (°)	荷重 (ton)
16.0	78.7	12.0								
18.0	77.2	12.0								
20.0	75.8	12.0	78.9	12.0						
22.0	74.3	12.0	77.4	12.0						
24.0	72.9	12.0	75.9	12.0	79.7	10.2				
26.0	71.4	12.0	74.2	11.3	78.0	9.9				
28.0	69.8	11.8	72.5	10.7	76.3	9.6	79.2	7.9		
30.0	68.1	11.1	70.9	10.2	74.6	9.3	77.4	7.7	79.3	6.9
32.0	66.4	10.4	69.2	9.7	72.7	8.9	75.5	7.6	77.2	6.8
34.0	64.6	9.8	67.4	9.3	70.9	8.4	73.5	7.4	75.1	6.7
36.0	62.9	9.3	65.6	8.9	69.0	7.9	71.6	7.2	72.9	6.6
38.0	61.0	8.8	63.8	8.4	67.0	7.5	69.5	6.9	70.6	6.6
40.0	58.9	7.5	61.7	7.8	65.0	7.1	67.3	6.6	68.3	6.3
42.0	56.8	6.3	59.8	7.3	63.0	6.7	65.0	6.3	65.7	6.1
44.0	54.6	5.3	57.5	6.1	60.7	6.3	62.7	6.0	63.1	5.9
46.0	52.3	4.3	55.2	5.1	58.5	6.0	60.2	5.7		
48.0	49.9	3.4	52.8	4.1	56.0	5.0	57.7	5.5		
50.0	47.6	2.6	50.3	3.2	53.4	4.0	54.8	4.5		
52.0	45.0	1.8	47.7	2.4	50.6	3.1	51.6	3.5		
54.0			45.0	1.6	47.6	2.3	48.3	2.5		
56.0					44.4	1.5				
掛数	1		1		1		1		1	
危険角度(°)	41		42		42		45		60	
フック種類	12t		12t		12t		12t		12t	
フック質量(t)	0.42		0.42		0.42		0.42		0.42	

SB性能

50.0mブーム+2m+23mスーパーラフィングジブ

オフセット 作業半径 (m)	5°		15°		30°		45°		60°	
	ブーム角 (°)	荷重 (ton)	ブーム角 (°)	荷重 (ton)	ブーム角 (°)	荷重 (ton)	ブーム角 (°)	荷重 (ton)	ブーム角 (°)	荷重 (ton)
16.0	79.6	11.0								
18.0	78.3	11.0								
20.0	77.0	11.0	79.8	11.0						
22.0	75.7	11.0	78.5	11.0						
24.0	74.4	11.0	77.2	11.0						
26.0	73.0	11.0	75.8	11.0	79.3	10.1				
28.0	71.7	11.0	74.4	11.0	77.8	9.8				
30.0	70.3	11.0	72.9	10.6	76.3	9.4	78.8	7.8		
32.0	68.8	10.9	71.3	9.8	74.6	8.7	77.1	7.7	78.7	6.8
34.0	67.2	10.0	69.7	9.1	72.9	8.1	75.4	7.5	76.9	6.7
36.0	65.5	9.1	67.9	8.4	71.1	7.6	73.5	7.0	74.9	6.7
38.0	63.7	8.3	66.2	7.8	69.4	7.1	71.6	6.6	72.8	6.4
40.0	61.9	7.3	64.4	7.2	67.5	6.6	69.7	6.2	70.7	6.0
42.0	59.9	6.1	62.7	6.7	65.6	6.2	67.7	5.8	68.5	5.7
44.0	57.9	5.0	60.7	5.9	63.7	5.8	65.7	5.5	66.3	5.4
46.0	55.9	4.0	58.6	4.9	61.7	5.4	63.5	5.2	63.9	5.1
48.0	53.7	3.1	56.5	3.9	59.6	4.9	61.3	4.9		
50.0	51.6	2.3	54.3	3.1	57.3	4.0	59.0	4.5		
52.0	49.4	1.6	52.0	2.2	54.9	3.1	56.3	3.5		
54.0			49.6	1.5	52.4	2.2	53.5	2.6		
56.0							50.6	1.7		
掛数	1		1		1		1		1	
危険角度(°)	47		47		48		48		60	
フック種類	12t		12t		12t		12t		12t	
フック質量(t)	0.42		0.42		0.42		0.42		0.42	

SB性能

40.9mブーム+2m+27mスーパーラフィングジブ

オフセット 作業半径 (m)	5°		15°		30°		45°		60°	
	ブーム角 (°)	荷重 (ton)	ブーム角 (°)	荷重 (ton)	ブーム角 (°)	荷重 (ton)	ブーム角 (°)	荷重 (ton)	ブーム角 (°)	荷重 (ton)
14.0	80.3	12.0								
16.0	78.9	12.0								
18.0	77.4	12.0								
20.0	75.9	12.0	79.5	11.2						
22.0	74.4	12.0	77.9	10.7						
24.0	72.8	11.4	76.2	10.2						
26.0	71.1	10.6	74.5	9.6	79.2	7.9				
28.0	69.4	9.9	72.8	9.1	77.4	7.6				
30.0	67.7	9.2	71.1	8.6	75.7	7.4	79.4	6.3		
32.0	65.9	8.6	69.3	8.1	73.8	7.2	77.4	6.1	80.0	5.4
34.0	64.1	8.1	67.5	7.7	71.9	7.0	75.4	6.0	77.7	5.3
36.0	62.2	7.6	65.6	7.4	70.0	6.8	73.3	5.8	75.4	5.2
38.0	60.3	7.2	63.7	7.0	68.0	6.6	71.1	5.7	73.0	5.2
40.0	58.4	6.8	61.8	6.7	65.9	6.4	68.9	5.5	70.4	5.1
42.0	56.4	6.4	59.7	6.4	63.8	6.2	66.6	5.4	67.9	5.1
44.0	54.4	6.1	57.6	6.1	61.6	6.0	64.2	5.3	65.1	5.1
46.0	52.0	5.4	55.4	5.9	59.4	5.8	61.7	5.3	62.1	5.1
48.0	49.6	4.5	53.1	5.3	56.9	5.7	59.0	5.2		
50.0	47.2	3.7	50.6	4.4	54.3	5.4	56.1	5.1		
52.0	44.5	2.9	47.8	3.6	51.5	4.4	53.0	4.9		
54.0	41.8	2.2	45.0	2.8	48.3	3.5	49.3	3.9		
56.0	38.9	1.5	42.0	2.1	45.0	2.7				
58.0			38.8	1.4	41.4	1.9				
掛数	1		1		1		1		1	
危険角度(°)	35		36		36		45		60	
フック種類	12t		12t		12t		12t		12t	
フック質量(t)	0.42		0.42		0.42		0.42		0.42	

SB性能

45.5mブーム+2m+27mスーパーラフィングジブ

オフセット 作業半径 (m)	5°		15°		30°		45°		60°	
	ブーム角 (°)	荷重 (ton)	ブーム角 (°)	荷重 (ton)	ブーム角 (°)	荷重 (ton)	ブーム角 (°)	荷重 (ton)	ブーム角 (°)	荷重 (ton)
16.0	79.8	11.0								
18.0	78.4	11.0								
20.0	77.1	11.0	80.5	11.0						
22.0	75.7	11.0	79.2	10.9						
24.0	74.3	11.0	77.6	10.4						
26.0	73.0	11.0	76.2	10.0	80.3	8.0				
28.0	71.5	10.5	74.6	9.4	78.8	7.8				
30.0	69.9	9.8	73.0	8.9	77.1	7.5				
32.0	68.3	9.2	71.4	8.5	75.5	7.3	78.8	6.2		
34.0	66.6	8.6	69.8	8.1	73.8	7.1	76.9	6.0	79.2	5.3
36.0	65.0	8.1	68.1	7.7	72.1	7.0	75.2	5.9	77.1	5.3
38.0	63.3	7.7	66.4	7.4	70.3	6.8	73.3	5.8	75.0	5.2
40.0	61.5	7.3	64.6	7.0	68.5	6.4	71.3	5.6	72.8	5.1
42.0	59.7	6.9	62.8	6.7	66.5	6.1	69.3	5.5	70.6	5.1
44.0	57.8	6.1	60.9	6.4	64.6	5.8	67.2	5.4	68.1	5.1
46.0	55.7	5.1	59.0	6.0	62.6	5.5	64.9	5.1	65.7	5.0
48.0	53.6	4.2	56.8	5.1	60.4	5.2	62.7	4.9	63.0	4.8
50.0	51.3	3.4	54.5	4.2	58.3	4.9	60.2	4.7		
52.0	49.1	2.6	52.2	3.4	55.8	4.3	57.6	4.5		
54.0	46.7	1.9	49.8	2.6	53.3	3.4	54.9	3.9		
56.0			47.3	1.9	50.5	2.6	51.7	3.0		
58.0					47.6	1.8	48.3	2.1		
掛数	1		1		1		1		1	
危険角度(°)	43		43		43		45		60	
フック種類	12t		12t		12t		12t		12t	
フック質量(t)	0.42		0.42		0.42		0.42		0.42	

SB性能

50.0mブーム+2m+27mスーパーラフィングジブ

オフセット 作業半径 (m)	5°		15°		30°		45°		60°	
	ブーム角 (°)	荷重 (ton)	ブーム角 (°)	荷重 (ton)	ブーム角 (°)	荷重 (ton)	ブーム角 (°)	荷重 (ton)	ブーム角 (°)	荷重 (ton)
18.0	79.1	9.0								
20.0	77.9	9.0								
22.0	76.7	9.0	79.9	9.0						
24.0	75.4	9.0	78.6	9.0						
26.0	74.1	9.0	77.3	9.0						
28.0	72.9	9.0	76.0	9.0	80.0	7.9				
30.0	71.6	9.0	74.7	9.0	78.5	7.6				
32.0	70.3	9.0	73.3	8.8	77.0	7.4	80.1	6.3		
34.0	68.9	9.0	71.8	8.4	75.5	7.3	78.4	6.1		
36.0	67.4	8.6	70.3	7.9	73.9	7.0	76.8	6.0	78.6	5.3
38.0	65.9	8.0	68.6	7.3	72.3	6.6	75.0	5.8	76.7	5.2
40.0	64.3	7.4	67.0	6.8	70.6	6.2	73.3	5.7	74.8	5.2
42.0	62.5	6.8	65.3	6.3	68.9	5.8	71.5	5.4	72.8	5.1
44.0	60.7	5.8	63.6	5.9	67.1	5.4	69.5	5.1	70.7	4.9
46.0	58.8	4.8	61.9	5.5	65.3	5.1	67.6	4.8	68.5	4.7
48.0	56.8	3.9	59.9	4.9	63.4	4.7	65.6	4.5	66.2	4.4
50.0	54.8	3.1	57.9	4.0	61.4	4.4	63.4	4.2	63.8	4.2
52.0	52.8	2.3	55.8	3.1	59.5	4.2	61.3	4.0		
54.0	50.7	1.6	53.7	2.4	57.1	3.3	59.0	3.8		
56.0			51.4	1.7	54.8	2.5	56.3	3.0		
58.0					52.2	1.8	53.6	2.2		
掛数	1		1		1		1		1	
危険角度(°)	48		49		49		49		60	
フック種類	12t		12t		12t		12t		12t	
フック質量(t)	0.42		0.42		0.42		0.42		0.42	

SB性能

40.9mブーム+2m+31mスーパーラフィングジブ

オフセット 作業半径 (m)	5°		15°		30°		45°		60°	
	ブーム角 (°)	荷重 (ton)	ブーム角 (°)	荷重 (ton)	ブーム角 (°)	荷重 (ton)	ブーム角 (°)	荷重 (ton)	ブーム角 (°)	荷重 (ton)
16.0	79.7	9.0								
18.0	78.3	9.0								
20.0	76.9	9.0								
22.0	75.5	9.0	79.6	9.0						
24.0	74.1	9.0	78.1	8.7						
26.0	72.7	9.0	76.5	8.3						
28.0	71.2	8.9	74.9	8.0	80.0	6.4				
30.0	69.6	8.3	73.3	7.6	78.4	6.2				
32.0	67.9	7.8	71.7	7.3	76.7	6.1				
34.0	66.2	7.3	70.0	6.9	74.9	5.9	79.0	4.9		
36.0	64.5	6.8	68.3	6.6	73.2	5.7	77.0	4.8		
38.0	62.8	6.4	66.4	6.2	71.2	5.5	75.1	4.7	77.7	4.2
40.0	61.0	6.1	64.6	5.9	69.4	5.3	73.1	4.6	75.4	4.2
42.0	59.1	5.7	62.8	5.7	67.5	5.1	70.9	4.5	73.0	4.1
44.0	57.2	5.4	60.9	5.4	65.5	5.0	68.8	4.4	70.5	4.1
46.0	55.3	5.1	59.0	5.2	63.4	4.8	66.5	4.3	67.8	4.0
48.0	53.4	4.9	56.9	5.0	61.2	4.7	64.0	4.2	64.9	4.0
50.0	51.2	4.4	54.8	4.8	59.0	4.6	61.6	4.2	62.0	4.0
52.0	48.8	3.7	52.6	4.5	56.6	4.5	58.9	4.1		
54.0	46.4	2.9	50.1	3.7	54.2	4.4	56.1	4.1		
56.0	43.8	2.3	47.4	3.0	51.4	3.8	52.9	4.0		
58.0	41.2	1.7	44.7	2.3	48.3	3.0	49.4	3.4		
60.0			41.7	1.6	45.0	2.3				
62.0					41.4	1.6				
掛数	1		1		1		1		1	
危険角度(°)	37		37		37		45		60	
フック種類	12t		12t		12t		12t		12t	
フック質量(t)	0.42		0.42		0.42		0.42		0.42	

SB性能

45.5mブーム+2m+31mスーパーラフィングジブ

オフセット 作業半径 (m)	5°		15°		30°		45°		60°	
	ブーム角 (°)	荷重 (ton)	ブーム角 (°)	荷重 (ton)	ブーム角 (°)	荷重 (ton)	ブーム角 (°)	荷重 (ton)	ブーム角 (°)	荷重 (ton)
18.0	79.3	9.0								
20.0	78.0	9.0								
22.0	76.8	9.0	80.6	9.0						
24.0	75.5	9.0	79.3	9.0						
26.0	74.2	9.0	77.8	8.5						
28.0	72.9	9.0	76.4	8.2						
30.0	71.5	8.8	74.9	7.8	79.6	6.3				
32.0	70.0	8.3	73.5	7.5	78.0	6.1				
34.0	68.5	7.7	72.0	7.2	76.4	6.0	80.2	5.0		
36.0	66.9	7.3	70.4	6.8	74.9	5.8	78.5	4.9		
38.0	65.3	6.9	68.8	6.5	73.2	5.6	76.6	4.7	79.1	4.2
40.0	63.7	6.5	67.1	6.2	71.5	5.4	74.8	4.6	77.1	4.2
42.0	62.1	6.1	65.5	6.0	69.8	5.3	72.9	4.5	75.0	4.1
44.0	60.4	5.8	63.8	5.7	68.0	5.1	71.1	4.5	72.7	4.1
46.0	58.7	5.5	62.0	5.5	66.2	5.0	69.1	4.4	70.5	4.0
48.0	56.8	4.9	60.2	5.2	64.3	4.8	67.0	4.3	68.1	4.0
50.0	54.8	4.1	58.4	5.0	62.2	4.5	64.9	4.2	65.6	4.0
52.0	52.6	3.3	56.3	4.2	60.2	4.3	62.6	4.1	62.9	4.0
54.0	50.5	2.6	54.0	3.4	58.0	4.1	60.2	3.9		
56.0	48.2	2.0	51.7	2.7	55.8	3.7	57.6	3.7		
58.0			49.3	2.0	53.1	2.9	54.8	3.4		
60.0			46.8	1.4	50.4	2.2	51.7	2.6		
62.0					47.5	1.5	48.3	1.8		
掛数	1		1		1		1		1	
危険角度(°)	44		44		45		45		60	
フック種類	12t		12t		12t		12t		12t	
フック質量(t)	0.42		0.42		0.42		0.42		0.42	

SB性能

50.0mブーム+2m+31mスーパーラフィングジブ

オフセット 作業半径 (m)	5°		15°		30°		45°		60°	
	ブーム角 (°)	荷重 (ton)	ブーム角 (°)	荷重 (ton)	ブーム角 (°)	荷重 (ton)	ブーム角 (°)	荷重 (ton)	ブーム角 (°)	荷重 (ton)
18.0	80.0	8.0								
20.0	78.8	8.0								
22.0	77.7	8.0								
24.0	76.6	8.0	80.1	8.0						
26.0	75.4	8.0	78.9	8.0						
28.0	74.1	8.0	77.7	8.0						
30.0	72.9	8.0	76.5	8.0	80.6	6.4				
32.0	71.7	8.0	75.0	7.7	79.3	6.2				
34.0	70.5	8.0	73.7	7.4	77.8	6.1				
36.0	69.2	7.7	72.3	7.1	76.4	5.9	79.7	4.9		
38.0	67.7	7.3	70.9	6.8	74.8	5.7	78.1	4.8		
40.0	66.2	6.9	69.4	6.4	73.4	5.5	76.5	4.7	78.6	4.2
42.0	64.7	6.5	67.8	6.0	71.8	5.4	74.8	4.6	76.7	4.1
44.0	63.2	6.0	66.3	5.6	70.2	5.1	73.1	4.5	74.8	4.1
46.0	61.5	5.5	64.6	5.2	68.4	4.7	71.3	4.4	72.8	4.1
48.0	59.7	4.6	62.9	4.8	66.7	4.4	69.4	4.2	70.7	4.0
50.0	57.8	3.8	61.3	4.5	64.9	4.2	67.5	4.0	68.5	3.9
52.0	55.9	3.0	59.3	4.0	63.1	3.9	65.5	3.7	66.1	3.7
54.0	53.9	2.3	57.4	3.2	61.2	3.7	63.4	3.5		
56.0	51.9	1.7	55.2	2.5	59.3	3.4	61.2	3.3		
58.0			53.2	1.8	56.9	2.8	58.9	3.1		
60.0					54.7	2.1	56.4	2.6		
62.0					52.1	1.4	53.6	1.8		
掛数	1		1		1		1		1	
危険角度(°)	49		50		50		50		60	
フック種類	12t		12t		12t		12t		12t	
フック質量(t)	0.42		0.42		0.42		0.42		0.42	

SC性能

40.9mブーム+2m+10mスーパーラフィングジブ

オフセット 作業半径 (m)	5°		15°		30°		45°		60°	
	ブーム角 (°)	荷重 (ton)	ブーム角 (°)	荷重 (ton)	ブーム角 (°)	荷重 (ton)	ブーム角 (°)	荷重 (ton)	ブーム角 (°)	荷重 (ton)
10.0	79.0	24.0								
11.0	78.1	24.0	79.8	24.0						
12.0	77.1	24.0	78.8	24.0						
14.0	75.1	24.0	76.8	24.0	79.1	24.0				
16.0	73.0	24.0	74.7	24.0	77.0	24.0	78.5	21.4	79.6	19.9
18.0	71.0	24.0	72.7	24.0	74.8	23.3	76.2	20.6	77.1	19.4
20.0	68.8	22.4	70.5	23.4	72.6	22.3	73.9	20.0	74.6	19.1
22.0	66.3	18.4	68.0	19.3	70.1	20.4	71.4	19.0	72.1	18.3
24.0	63.7	15.2	65.4	16.0	67.4	16.9	68.9	17.6	69.4	17.4
26.0	61.2	12.6	62.8	13.3	64.8	14.1	66.0	14.6	66.4	14.8
28.0	58.5	10.4	60.1	11.0	62.0	11.7	63.2	12.1	63.4	12.3
30.0	55.8	8.6	57.4	9.1	59.2	9.7	60.2	10.0		
32.0	53.0	6.6	54.6	7.3	56.2	7.9	57.1	8.2		
34.0	50.1	4.8	51.6	5.4	53.2	6.0	53.8	6.3		
36.0	46.9	3.3	48.4	3.8	49.9	4.3	50.3	4.5		
38.0					46.4	2.7				
掛数	2		2		2		2		2	
危険角度(°)	43		44		44		45		60	
フック種類	24t		24t		24t		24t		24t	
フック質量(t)	0.88		0.88		0.88		0.88		0.88	

SC性能

45.5mブーム+2m+10mスーパーラフィングジブ

オフセット 作業半径 (m)	5°		15°		30°		45°		60°	
	ブーム角 (°)	荷重 (ton)	ブーム角 (°)	荷重 (ton)	ブーム角 (°)	荷重 (ton)	ブーム角 (°)	荷重 (ton)	ブーム角 (°)	荷重 (ton)
11.0	79.4	24.0								
12.0	78.5	24.0								
14.0	76.8	24.0	78.3	24.0						
16.0	75.0	24.0	76.6	24.0	78.6	24.0				
18.0	73.2	24.0	74.8	24.0	76.6	22.1	78.0	19.8	78.8	18.6
20.0	71.3	22.4	72.9	23.4	74.5	20.4	75.8	18.5	76.5	17.5
22.0	69.0	18.4	70.6	19.2	72.4	18.9	73.7	17.3	74.3	16.5
24.0	66.7	15.2	68.3	15.9	70.2	16.9	71.4	16.2	71.9	15.6
26.0	64.4	12.5	65.9	13.2	67.8	14.1	69.1	14.7	69.6	14.8
28.0	62.0	10.4	63.6	11.0	65.3	11.7	66.5	12.2	66.9	12.4
30.0	59.6	8.5	61.1	9.0	62.8	9.7	63.8	10.1	64.1	10.2
32.0	57.1	6.5	58.6	7.2	60.3	8.0	61.2	8.3		
34.0	54.6	4.7	56.0	5.4	57.6	6.1	58.4	6.5		
36.0	51.8	3.2	53.2	3.7	54.8	4.3	55.4	4.6		
38.0					51.8	2.8	52.3	3.0		
掛数	2		2		2		2		2	
危険角度(°)	49		49		49		49		60	
フック種類	24t		24t		24t		24t		24t	
フック質量(t)	0.88		0.88		0.88		0.88		0.88	

SC性能

50.0mブーム+2m+10mスーパーラフィングジブ

オフセット 作業半径 (m)	5°		15°		30°		45°		60°	
	ブーム角 (°)	荷重 (ton)	ブーム角 (°)	荷重 (ton)	ブーム角 (°)	荷重 (ton)	ブーム角 (°)	荷重 (ton)	ブーム角 (°)	荷重 (ton)
12.0	79.5	20.0								
14.0	77.9	20.0	79.4	20.0						
16.0	76.4	20.0	77.8	20.0	79.7	20.0				
18.0	74.7	20.0	76.2	20.0	78.0	20.0	79.4	19.6		
20.0	73.2	20.0	74.6	20.0	76.3	19.6	77.5	18.0	78.2	17.1
22.0	71.3	18.3	72.8	19.2	74.5	17.9	75.6	16.6	76.2	15.9
24.0	69.2	15.1	70.7	15.9	72.5	16.4	73.5	15.3	74.0	14.8
26.0	67.1	12.5	68.5	13.2	70.4	14.1	71.5	14.2	72.0	13.8
28.0	65.0	10.3	66.4	10.9	68.1	11.7	69.3	12.2	69.7	12.5
30.0	62.8	8.5	64.2	9.0	65.8	9.7	66.9	10.2	67.2	10.3
32.0	60.5	6.4	61.9	7.2	63.5	8.0	64.5	8.4	64.7	8.5
34.0	58.2	4.7	59.6	5.3	61.1	6.1	62.1	6.5		
36.0	55.8	3.1	57.1	3.7	58.6	4.4	59.4	4.7		
38.0					56.1	2.8	56.7	3.1		
掛数	2		2		2		2		2	
危険角度(°)	53		54		54		54		60	
フック種類	24t		24t		24t		24t		24t	
フック質量(t)	0.88		0.88		0.88		0.88		0.88	

SC性能

40.9mブーム+2m+15mスーパーラフィングジブ

オフセット 作業半径 (m)	5°		15°		30°		45°		60°	
	ブーム角 (°)	荷重 (ton)	ブーム角 (°)	荷重 (ton)	ブーム角 (°)	荷重 (ton)	ブーム角 (°)	荷重 (ton)	ブーム角 (°)	荷重 (ton)
11.0	79.3	12.0								
12.0	78.3	12.0								
14.0	76.5	12.0	78.9	12.0						
16.0	74.6	12.0	77.0	12.0						
18.0	72.7	12.0	75.1	12.0	78.3	12.0				
20.0	70.8	12.0	73.2	12.0	76.3	12.0	78.8	12.0		
22.0	68.8	12.0	71.2	12.0	74.3	12.0	76.7	12.0	78.2	12.0
24.0	66.8	12.0	69.2	12.0	72.2	12.0	74.4	12.0	75.9	12.0
26.0	64.8	12.0	67.1	12.0	70.0	12.0	72.2	12.0	73.4	12.0
28.0	62.7	12.0	64.9	12.0	67.8	12.0	69.9	12.0	70.9	12.0
30.0	60.4	10.1	62.7	10.9	65.5	11.9	67.4	12.0	68.2	11.9
32.0	57.9	8.5	60.1	9.2	62.9	10.1	64.7	10.7	65.3	10.9
34.0	55.4	6.9	57.6	7.7	60.3	8.5	61.9	9.0	62.2	9.2
36.0	52.7	5.3	54.9	6.1	57.5	7.1	59.0	7.5		
38.0	50.0	3.9	52.1	4.6	54.6	5.5	55.8	6.0		
40.0	47.1	2.7	49.2	3.3	51.5	4.0	52.5	4.4		
42.0	44.1	1.5	46.2	2.1	48.2	2.7	48.9	3.0		
掛数	1		1		1		1		1	
危険角度(°)	42		42		43		45		60	
フック種類	12t		12t		12t		12t		12t	
フック質量(t)	0.42		0.42		0.42		0.42		0.42	

SC性能

45.5mブーム+2m+15mスーパーラフィングジブ

オフセット 作業半径 (m)	5°		15°		30°		45°		60°	
	ブーム角 (°)	荷重 (ton)	ブーム角 (°)	荷重 (ton)	ブーム角 (°)	荷重 (ton)	ブーム角 (°)	荷重 (ton)	ブーム角 (°)	荷重 (ton)
14.0	77.8	12.0								
16.0	76.1	12.0	78.4	12.0						
18.0	74.4	12.0	76.6	12.0						
20.0	72.8	12.0	74.9	12.0	77.8	12.0				
22.0	71.0	12.0	73.2	12.0	76.0	12.0	78.2	12.0		
24.0	69.3	12.0	71.4	12.0	74.2	12.0	76.2	12.0	77.6	12.0
26.0	67.5	12.0	69.5	12.0	72.2	12.0	74.2	12.0	75.4	11.7
28.0	65.6	11.9	67.7	12.0	70.3	12.0	72.2	11.7	73.1	11.2
30.0	63.5	10.0	65.6	10.8	68.3	11.8	70.0	11.1	70.9	10.7
32.0	61.2	8.4	63.4	9.1	66.1	10.0	67.7	10.5	68.4	10.2
34.0	59.0	6.7	61.1	7.6	63.7	8.5	65.3	9.0	65.8	9.3
36.0	56.6	5.1	58.7	6.0	61.2	7.1	62.7	7.6	63.0	7.7
38.0	54.2	3.7	56.2	4.5	58.6	5.5	60.0	6.1		
40.0	51.7	2.5	53.7	3.2	56.0	4.0	57.2	4.5		
42.0			51.1	2.0	53.2	2.7	54.2	3.1		
44.0					50.3	1.5	51.1	1.8		
掛数	1		1		1		1		1	
危険角度(°)	48		48		48		48		60	
フック種類	12t		12t		12t		12t		12t	
フック質量(t)	0.42		0.42		0.42		0.42		0.42	

SC性能

50.0mブーム+2m+15mスーパーラフィングジブ

オフセット 作業半径 (m)	5°		15°		30°		45°		60°	
	ブーム角 (°)	荷重 (ton)	ブーム角 (°)	荷重 (ton)	ブーム角 (°)	荷重 (ton)	ブーム角 (°)	荷重 (ton)	ブーム角 (°)	荷重 (ton)
14.0	78.9	12.0								
16.0	77.4	12.0	79.4	12.0						
18.0	76.0	12.0	78.0	12.0						
20.0	74.5	12.0	76.4	12.0	79.1	12.0				
22.0	72.9	12.0	74.9	12.0	77.5	12.0	79.6	12.0		
24.0	71.3	12.0	73.3	12.0	75.9	12.0	77.8	12.0	79.1	12.0
26.0	69.7	12.0	71.7	12.0	74.2	12.0	76.1	12.0	77.1	11.5
28.0	68.1	11.8	70.0	12.0	72.6	12.0	74.3	11.4	75.2	10.9
30.0	66.1	9.9	68.2	10.7	70.7	11.4	72.3	10.6	73.1	10.2
32.0	64.1	8.3	66.1	9.0	68.6	10.0	70.3	9.9	70.9	9.6
34.0	62.0	6.6	64.1	7.5	66.5	8.4	68.2	9.0	68.7	9.1
36.0	59.9	5.0	61.9	5.9	64.3	7.0	65.8	7.6	66.3	7.8
38.0	57.7	3.6	59.7	4.4	62.0	5.4	63.4	6.1	63.7	6.3
40.0	55.4	2.3	57.4	3.1	59.7	4.0	60.9	4.6		
42.0			55.1	1.9	57.2	2.7	58.4	3.2		
44.0							55.7	1.9		
掛数	1		1		1		1		1	
危険角度(°)	52		53		53		53		60	
フック種類	12t		12t		12t		12t		12t	
フック質量(t)	0.42		0.42		0.42		0.42		0.42	

SC性能

40.9mブーム+2m+19mスーパーラフィングジブ

オフセット	5°		15°		30°		45°		60°	
作業半径 (m)	ブーム角 (°)	荷重 (ton)	ブーム角 (°)	荷重 (ton)	ブーム角 (°)	荷重 (ton)	ブーム角 (°)	荷重 (ton)	ブーム角 (°)	荷重 (ton)
12.0	79.5	12.0								
14.0	77.8	12.0								
16.0	76.1	12.0	79.0	12.0						
18.0	74.4	12.0	77.3	12.0						
20.0	72.7	12.0	75.5	12.0	79.4	12.0				
22.0	70.9	12.0	73.7	12.0	77.4	12.0				
24.0	69.1	12.0	71.8	12.0	75.5	12.0	78.4	10.4		
26.0	67.2	12.0	69.9	12.0	73.6	11.6	76.2	10.2	78.0	9.1
28.0	65.3	12.0	68.0	12.0	71.5	11.1	74.0	9.9	75.7	9.0
30.0	63.2	11.0	66.0	11.4	69.4	10.7	71.8	9.7	73.2	8.9
32.0	61.0	9.4	63.7	10.2	67.2	10.3	69.5	9.4	70.7	8.8
34.0	58.7	7.9	61.5	8.7	64.9	9.8	67.1	9.2	68.0	8.8
36.0	56.3	6.6	59.0	7.4	62.4	8.3	64.6	9.0	65.3	8.8
38.0	53.9	5.1	56.5	6.1	59.8	7.1	61.8	7.7	62.2	7.9
40.0	51.3	3.9	53.9	4.7	57.1	5.8	58.9	6.4		
42.0	48.6	2.7	51.2	3.5	54.2	4.4	55.7	5.0		
44.0	45.8	1.7	48.4	2.4	51.2	3.2	52.5	3.6		
46.0					48.1	2.1	48.9	2.4		
掛数	1		1		1		1		1	
危険角度(°)	43		44		44		45		60	
フック種類	12t		12t		12t		12t		12t	
フック質量(t)	0.42		0.42		0.42		0.42		0.42	

SC性能

45.5mブーム+2m+19mスーパーラフィングジブ

オフセット	5°		15°		30°		45°		60°	
作業半径 (m)	ブーム角 (°)	荷重 (ton)	ブーム角 (°)	荷重 (ton)	ブーム角 (°)	荷重 (ton)	ブーム角 (°)	荷重 (ton)	ブーム角 (°)	荷重 (ton)
14.0	79.0	12.0								
16.0	77.4	12.0								
18.0	75.9	12.0	78.5	12.0						
20.0	74.3	12.0	77.0	12.0						
22.0	72.8	12.0	75.3	12.0	78.9	12.0				
24.0	71.1	12.0	73.7	12.0	77.1	12.0	79.7	10.6		
26.0	69.5	12.0	72.1	12.0	75.4	11.9	77.9	10.3	79.5	9.2
28.0	67.8	12.0	70.3	12.0	73.5	11.2	76.0	10.1	77.4	9.1
30.0	65.9	10.8	68.6	11.8	71.6	10.5	74.0	9.6	75.3	9.0
32.0	63.9	9.2	66.6	10.1	69.6	9.9	71.9	9.1	73.0	8.6
34.0	61.8	7.8	64.4	8.6	67.6	9.3	69.7	8.6	70.7	8.3
36.0	59.7	6.3	62.2	7.3	65.4	8.3	67.5	8.2	68.3	7.9
38.0	57.5	4.9	60.0	5.9	63.2	7.0	65.2	7.7	65.8	7.6
40.0	55.2	3.6	57.7	4.5	60.8	5.7	62.6	6.4	63.1	6.6
42.0	52.8	2.5	55.3	3.3	58.2	4.3	60.0	5.0		
44.0			52.8	2.2	55.6	3.1	57.2	3.7		
46.0					52.9	2.0	54.2	2.5		
掛数	1		1		1		1		1	
危険角度(°)	49		49		50		50		60	
フック種類	12t		12t		12t		12t		12t	
フック質量(t)	0.42		0.42		0.42		0.42		0.42	

SC性能

50.0mブーム+2m+19mスーパーラフィングジブ

オフセット	5°		15°		30°		45°		60°	
作業半径 (m)	ブーム角 (°)	荷重 (ton)	ブーム角 (°)	荷重 (ton)	ブーム角 (°)	荷重 (ton)	ブーム角 (°)	荷重 (ton)	ブーム角 (°)	荷重 (ton)
16.0	78.6	12.0								
18.0	77.2	12.0	79.7	12.0						
20.0	75.8	12.0	78.3	12.0						
22.0	74.4	12.0	76.8	12.0	80.2	12.0				
24.0	73.0	12.0	75.4	12.0	78.6	12.0				
26.0	71.6	12.0	73.9	12.0	77.1	11.9	79.3	10.4		
28.0	70.1	12.0	72.5	12.0	75.3	11.0	77.6	10.0	78.9	9.1
30.0	68.3	10.7	70.8	11.5	73.6	10.2	75.7	9.4	77.0	8.9
32.0	66.4	9.0	68.9	10.0	71.8	9.5	73.8	8.8	75.0	8.4
34.0	64.5	7.6	67.0	8.5	69.9	8.9	71.9	8.3	72.9	7.9
36.0	62.5	6.1	65.0	7.2	68.1	8.2	69.9	7.7	70.8	7.5
38.0	60.5	4.7	63.0	5.7	66.0	7.0	67.9	7.3	68.7	7.1
40.0	58.4	3.4	60.8	4.4	63.8	5.6	65.7	6.4	66.4	6.7
42.0	56.3	2.2	58.6	3.1	61.6	4.3	63.4	5.1	63.7	5.3
44.0			56.4	2.0	59.2	3.1	60.8	3.7		
46.0					56.8	2.0	58.3	2.5		
掛数	1		1		1		1		1	
危険角度(°)	53		54		54		54		60	
フック種類	12t		12t		12t		12t		12t	
フック質量(t)	0.42		0.42		0.42		0.42		0.42	

SC性能

40.9mブーム+2m+23mスーパーラフィングジブ

オフセット	5°		15°		30°		45°		60°	
作業半径 (m)	ブーム角 (°)	荷重 (ton)	ブーム角 (°)	荷重 (ton)	ブーム角 (°)	荷重 (ton)	ブーム角 (°)	荷重 (ton)	ブーム角 (°)	荷重 (ton)
14.0	79.1	12.0								
16.0	77.5	12.0								
18.0	75.9	12.0	79.2	12.0						
20.0	74.3	12.0	77.6	12.0						
22.0	72.7	12.0	76.0	12.0	80.2	10.4				
24.0	71.0	12.0	74.2	11.5	78.4	10.1				
26.0	69.3	11.9	72.4	10.9	76.5	9.8	79.9	8.1		
28.0	67.5	11.1	70.5	10.3	74.6	9.4	77.8	7.8		
30.0	65.6	10.4	68.6	9.8	72.6	9.0	75.7	7.6	77.9	6.8
32.0	63.7	9.8	66.7	9.3	70.6	8.7	73.6	7.5	75.5	6.7
34.0	61.7	8.7	64.7	8.8	68.6	8.4	71.4	7.3	73.1	6.7
36.0	59.5	7.4	62.7	8.3	66.5	8.1	69.2	7.1	70.5	6.6
38.0	57.2	6.2	60.4	7.1	64.3	7.8	66.8	7.0	67.9	6.6
40.0	54.9	4.9	58.1	6.0	61.9	7.0	64.3	6.9	65.1	6.5
42.0	52.5	3.8	55.6	4.7	59.4	6.0	61.8	6.6	62.2	6.5
44.0	50.0	2.7	53.1	3.6	56.8	4.7	58.9	5.5		
46.0	47.4	1.8	50.4	2.6	53.9	3.6	55.8	4.2		
48.0			47.7	1.6	51.0	2.5	52.4	3.0		
50.0					47.8	1.5	48.9	1.9		
掛数	1		1		1		1		1	
危険角度(°)	44		45		45		45		60	
フック種類	12t		12t		12t		12t		12t	
フック質量(t)	0.42		0.42		0.42		0.42		0.42	

SC性能

45.5mブーム+2m+23mスーパーラフィングジブ

オフセット	5°		15°		30°		45°		60°	
作業半径 (m)	ブーム角 (°)	荷重 (ton)	ブーム角 (°)	荷重 (ton)	ブーム角 (°)	荷重 (ton)	ブーム角 (°)	荷重 (ton)	ブーム角 (°)	荷重 (ton)
16.0	78.7	12.0								
18.0	77.2	12.0								
20.0	75.8	12.0	78.9	12.0						
22.0	74.3	12.0	77.4	12.0						
24.0	72.9	12.0	75.9	12.0	79.7	10.2				
26.0	71.4	12.0	74.2	11.3	78.0	9.9				
28.0	69.8	11.8	72.5	10.7	76.3	9.6	79.2	7.9		
30.0	68.1	11.1	70.9	10.2	74.6	9.3	77.4	7.7	79.3	6.9
32.0	66.3	9.9	69.2	9.7	72.7	8.9	75.5	7.6	77.2	6.8
34.0	64.4	8.5	67.4	9.3	70.9	8.4	73.5	7.4	75.1	6.7
36.0	62.4	7.2	65.4	8.1	69.0	7.9	71.6	7.2	72.9	6.6
38.0	60.3	5.9	63.4	7.0	67.0	7.5	69.5	6.9	70.6	6.6
40.0	58.2	4.6	61.2	5.7	64.9	6.9	67.3	6.6	68.3	6.3
42.0	56.1	3.5	59.1	4.5	62.7	5.8	65.0	6.3	65.7	6.1
44.0	53.9	2.4	56.7	3.4	60.3	4.6	62.6	5.5	63.1	5.8
46.0			54.4	2.4	57.8	3.5	59.9	4.2		
48.0			52.0	1.4	55.3	2.4	57.1	3.0		
50.0							54.2	2.0		
掛数	1		1		1		1		1	
危険角度(°)	50		50		51		51		60	
フック種類	12t		12t		12t		12t		12t	
フック質量(t)	0.42		0.42		0.42		0.42		0.42	

SC性能

50.0mブーム+2m+23mスーパーラフィングジブ

オフセット	5°		15°		30°		45°		60°	
作業半径 (m)	ブーム角 (°)	荷重 (ton)	ブーム角 (°)	荷重 (ton)	ブーム角 (°)	荷重 (ton)	ブーム角 (°)	荷重 (ton)	ブーム角 (°)	荷重 (ton)
16.0	79.6	11.0								
18.0	78.3	11.0								
20.0	77.0	11.0	79.8	11.0						
22.0	75.7	11.0	78.5	11.0						
24.0	74.4	11.0	77.2	11.0						
26.0	73.0	11.0	75.8	11.0	79.3	10.1				
28.0	71.7	11.0	74.4	11.0	77.8	9.8				
30.0	70.3	11.0	72.9	10.6	76.3	9.4	78.8	7.8		
32.0	68.6	9.7	71.3	9.8	74.6	8.7	77.1	7.7	78.7	6.8
34.0	66.8	8.3	69.7	9.1	72.9	8.1	75.4	7.5	76.9	6.7
36.0	64.9	7.1	67.8	8.0	71.1	7.6	73.5	7.0	74.9	6.7
38.0	63.0	5.6	66.0	6.8	69.4	7.1	71.6	6.6	72.8	6.4
40.0	61.1	4.4	63.9	5.5	67.5	6.6	69.7	6.2	70.7	6.0
42.0	59.1	3.2	62.0	4.3	65.5	5.7	67.7	5.8	68.5	5.7
44.0	57.0	2.2	59.9	3.2	63.3	4.5	65.6	5.4	66.3	5.4
46.0			57.7	2.2	61.1	3.4	63.3	4.2	63.7	4.5
48.0					58.8	2.3	60.8	3.1		
50.0							58.3	2.0		
掛数	1		1		1		1		1	
危険角度(°)	54		55		55		55		60	
フック種類	12t		12t		12t		12t		12t	
フック質量(t)	0.42		0.42		0.42		0.42		0.42	

SC性能

40.9mブーム+2m+27mスーパーラフィングジブ

オフセット	5°		15°		30°		45°		60°	
作業半径 (m)	ブーム角 (°)	荷重 (ton)	ブーム角 (°)	荷重 (ton)	ブーム角 (°)	荷重 (ton)	ブーム角 (°)	荷重 (ton)	ブーム角 (°)	荷重 (ton)
14.0	80.3	12.0								
16.0	78.9	12.0								
18.0	77.4	12.0								
20.0	75.9	12.0	79.5	11.2						
22.0	74.4	12.0	77.9	10.7						
24.0	72.8	11.4	76.2	10.2						
26.0	71.1	10.6	74.5	9.6	79.2	7.9				
28.0	69.4	9.9	72.8	9.1	77.4	7.6				
30.0	67.7	9.2	71.1	8.6	75.7	7.4	79.4	6.3		
32.0	65.9	8.6	69.3	8.1	73.8	7.2	77.4	6.1	80.0	5.4
34.0	64.1	8.1	67.5	7.7	71.9	7.0	75.4	6.0	77.7	5.3
36.0	62.2	7.6	65.6	7.4	70.0	6.8	73.3	5.8	75.4	5.2
38.0	60.3	7.0	63.7	7.0	68.0	6.6	71.1	5.7	73.0	5.2
40.0	58.2	5.9	61.8	6.7	65.9	6.4	68.9	5.5	70.4	5.1
42.0	55.9	4.7	59.6	5.8	63.8	6.2	66.6	5.4	67.9	5.1
44.0	53.7	3.7	57.2	4.7	61.6	6.0	64.2	5.3	65.1	5.1
46.0	51.3	2.7	54.8	3.7	59.1	4.9	61.7	5.3	62.1	5.1
48.0	48.8	1.8	52.3	2.7	56.4	3.9	58.9	4.6		
50.0			49.8	1.8	53.7	2.9	55.8	3.5		
52.0					50.8	1.9	52.5	2.5		
掛数	1		1		1		1		1	
危険角度(°)	46		46		47		47		60	
フック種類	12t		12t		12t		12t		12t	
フック質量(t)	0.42		0.42		0.42		0.42		0.42	

SC性能

45.5mブーム+2m+27mスーパーラフィングジブ

オフセット	5°		15°		30°		45°		60°	
作業半径 (m)	ブーム角 (°)	荷重 (ton)	ブーム角 (°)	荷重 (ton)	ブーム角 (°)	荷重 (ton)	ブーム角 (°)	荷重 (ton)	ブーム角 (°)	荷重 (ton)
16.0	79.8	11.0								
18.0	78.4	11.0								
20.0	77.1	11.0	80.5	11.0						
22.0	75.7	11.0	79.2	10.9						
24.0	74.3	11.0	77.6	10.4						
26.0	73.0	11.0	76.2	10.0	80.3	8.0				
28.0	71.5	10.5	74.6	9.4	78.8	7.8				
30.0	69.9	9.8	73.0	8.9	77.1	7.5				
32.0	68.3	9.2	71.4	8.5	75.5	7.3	78.8	6.2		
34.0	66.6	8.6	69.8	8.1	73.8	7.1	76.9	6.0	79.2	5.3
36.0	64.9	7.9	68.1	7.7	72.1	7.0	75.2	5.9	77.1	5.3
38.0	63.0	6.8	66.4	7.4	70.3	6.8	73.3	5.8	75.0	5.2
40.0	61.0	5.5	64.5	6.7	68.5	6.4	71.3	5.6	72.8	5.1
42.0	59.0	4.4	62.5	5.6	66.5	6.1	69.3	5.5	70.6	5.1
44.0	56.9	3.3	60.3	4.4	64.6	5.8	67.2	5.4	68.1	5.1
46.0	54.8	2.4	58.2	3.4	62.4	4.8	64.9	5.1	65.7	5.0
48.0			56.0	2.5	60.0	3.7	62.6	4.6	63.0	4.8
50.0					57.6	2.7	59.9	3.5		
52.0					55.0	1.8	57.1	2.5		
54.0							54.2	1.5		
掛数	1		1		1		1		1	
危険角度(°)	51		52		52		52		60	
フック種類	12t		12t		12t		12t		12t	
フック質量(t)	0.42		0.42		0.42		0.42		0.42	

SC性能

50.0mブーム+2m+27mスーパーラフィングジブ

オフセット	5°		15°		30°		45°		60°	
作業半径 (m)	ブーム角 (°)	荷重 (ton)	ブーム角 (°)	荷重 (ton)	ブーム角 (°)	荷重 (ton)	ブーム角 (°)	荷重 (ton)	ブーム角 (°)	荷重 (ton)
18.0	79.1	9.0								
20.0	77.9	9.0								
22.0	76.7	9.0	79.9	9.0						
24.0	75.4	9.0	78.6	9.0						
26.0	74.1	9.0	77.3	9.0						
28.0	72.9	9.0	76.0	9.0	80.0	7.9				
30.0	71.6	9.0	74.7	9.0	78.5	7.6				
32.0	70.3	9.0	73.3	8.8	77.0	7.4	80.1	6.3		
34.0	68.9	8.9	71.8	8.4	75.5	7.3	78.4	6.1		
36.0	67.1	7.7	70.3	7.9	73.9	7.0	76.8	6.0	78.6	5.3
38.0	65.4	6.5	68.6	7.3	72.3	6.6	75.0	5.8	76.7	5.2
40.0	63.6	5.2	66.9	6.5	70.6	6.2	73.3	5.7	74.8	5.2
42.0	61.6	4.1	65.0	5.3	68.9	5.8	71.5	5.4	72.8	5.1
44.0	59.8	3.0	63.0	4.2	67.1	5.4	69.5	5.1	70.7	4.9
46.0	57.9	2.1	61.0	3.2	65.1	4.6	67.6	4.8	68.5	4.7
48.0			59.0	2.2	63.0	3.6	65.6	4.5	66.2	4.4
50.0					60.7	2.6	63.2	3.5	63.7	3.9
52.0					58.6	1.7	60.8	2.5		
54.0							58.2	1.5		
掛数	1		1		1		1		1	
危険角度(°)	55		56		56		56		60	
フック種類	12t		12t		12t		12t		12t	
フック質量(t)	0.42		0.42		0.42		0.42		0.42	

SC性能

40.9mブーム+2m+31mスーパーラフィングジブ

オフセット 作業半径 (m)	5°		15°		30°		45°		60°	
	ブーム角 (°)	荷重 (ton)	ブーム角 (°)	荷重 (ton)	ブーム角 (°)	荷重 (ton)	ブーム角 (°)	荷重 (ton)	ブーム角 (°)	荷重 (ton)
16.0	79.7	9.0								
18.0	78.3	9.0								
20.0	76.9	9.0								
22.0	75.5	9.0	79.6	9.0						
24.0	74.1	9.0	78.1	8.7						
26.0	72.7	9.0	76.5	8.3						
28.0	71.2	8.9	74.9	8.0	80.0	6.4				
30.0	69.6	8.3	73.3	7.6	78.4	6.2				
32.0	67.9	7.8	71.7	7.3	76.7	6.1				
34.0	66.2	7.3	70.0	6.9	74.9	5.9	79.0	4.9		
36.0	64.5	6.8	68.3	6.6	73.2	5.7	77.0	4.8		
38.0	62.8	6.4	66.4	6.2	71.2	5.5	75.1	4.7	77.7	4.2
40.0	61.0	6.1	64.6	5.9	69.4	5.3	73.1	4.6	75.4	4.2
42.0	59.1	5.5	62.8	5.7	67.5	5.1	70.9	4.5	73.0	4.1
44.0	56.9	4.5	60.9	5.4	65.5	5.0	68.8	4.4	70.5	4.1
46.0	54.8	3.5	58.8	4.6	63.4	4.8	66.5	4.3	67.8	4.0
48.0	52.6	2.7	56.5	3.7	61.2	4.7	64.0	4.2	64.9	4.0
50.0	50.2	1.9	54.1	2.8	58.8	4.1	61.6	4.2	62.0	4.0
52.0			51.7	2.0	56.2	3.1	58.8	4.0		
54.0					53.5	2.3	55.8	3.0		
56.0					50.7	1.5	52.4	2.0		
掛数	1		1		1		1		1	
危険角度(°)	47		48		48		48		60	
フック種類	12t		12t		12t		12t		12t	
フック質量(t)	0.42		0.42		0.42		0.42		0.42	

SC性能

45.5mブーム+2m+31mスーパーラフィングジブ

オフセット 作業半径 (m)	5°		15°		30°		45°		60°	
	ブーム角 (°)	荷重 (ton)	ブーム角 (°)	荷重 (ton)	ブーム角 (°)	荷重 (ton)	ブーム角 (°)	荷重 (ton)	ブーム角 (°)	荷重 (ton)
18.0	79.3	9.0								
20.0	78.0	9.0								
22.0	76.8	9.0	80.6	9.0						
24.0	75.5	9.0	79.3	9.0						
26.0	74.2	9.0	77.8	8.5						
28.0	72.9	9.0	76.4	8.2						
30.0	71.5	8.8	74.9	7.8	79.6	6.3				
32.0	70.0	8.3	73.5	7.5	78.0	6.1				
34.0	68.5	7.7	72.0	7.2	76.4	6.0	80.2	5.0		
36.0	66.9	7.3	70.4	6.8	74.9	5.8	78.5	4.9		
38.0	65.3	6.9	68.8	6.5	73.2	5.6	76.6	4.7	79.1	4.2
40.0	63.7	6.3	67.1	6.2	71.5	5.4	74.8	4.6	77.1	4.2
42.0	61.8	5.2	65.5	6.0	69.8	5.3	72.9	4.5	75.0	4.1
44.0	59.8	4.1	63.7	5.4	68.0	5.1	71.1	4.5	72.7	4.1
46.0	57.8	3.2	61.6	4.4	66.2	5.0	69.1	4.4	70.5	4.0
48.0	55.8	2.3	59.5	3.4	64.3	4.8	67.0	4.3	68.1	4.0
50.0			57.4	2.5	62.0	3.9	64.9	4.2	65.6	4.0
52.0			55.3	1.7	59.7	3.0	62.6	3.9	62.9	4.0
54.0					57.3	2.1	59.9	2.9		
56.0							57.1	2.0		
掛数	1		1		1		1		1	
危険角度(°)	52		53		53		53		60	
フック種類	12t		12t		12t		12t		12t	
フック質量(t)	0.42		0.42		0.42		0.42		0.42	

SC性能

50.0mブーム+2m+31mスーパーラフィングジブ

オフセット 作業半径 (m)	5°		15°		30°		45°		60°	
	ブーム角 (°)	荷重 (ton)	ブーム角 (°)	荷重 (ton)	ブーム角 (°)	荷重 (ton)	ブーム角 (°)	荷重 (ton)	ブーム角 (°)	荷重 (ton)
18.0	80.0	8.0								
20.0	78.8	8.0								
22.0	77.7	8.0								
24.0	76.6	8.0	80.1	8.0						
26.0	75.4	8.0	78.9	8.0						
28.0	74.1	8.0	77.7	8.0						
30.0	72.9	8.0	76.5	8.0	80.6	6.4				
32.0	71.7	8.0	75.0	7.7	79.3	6.2				
34.0	70.5	8.0	73.7	7.4	77.8	6.1				
36.0	69.2	7.7	72.3	7.1	76.4	5.9	79.7	4.9		
38.0	67.6	7.1	70.9	6.8	74.8	5.7	78.1	4.8		
40.0	65.9	6.0	69.4	6.4	73.4	5.5	76.5	4.7	78.6	4.2
42.0	64.1	4.8	67.8	6.0	71.8	5.4	74.8	4.6	76.7	4.1
44.0	62.3	3.8	66.1	5.1	70.2	5.1	73.1	4.5	74.8	4.1
46.0	60.5	2.9	64.2	4.1	68.4	4.7	71.3	4.4	72.8	4.1
48.0	58.6	2.0	62.2	3.2	66.7	4.4	69.4	4.2	70.7	4.0
50.0			60.3	2.3	64.7	3.8	67.5	4.0	68.5	3.9
52.0					62.6	2.8	65.5	3.7	66.1	3.7
54.0					60.5	2.0	63.2	2.9		
56.0							60.7	2.0		
掛数	1		1		1		1		1	
危険角度(°)	56		57		57		57		60	
フック種類	12t		12t		12t		12t		12t	
フック質量(t)	0.42		0.42		0.42		0.42		0.42	

SD性能

40.9mブーム+2m+10mスーパーラフィングジブ

オフセット 作業半径 (m)	5°		15°		30°		45°		60°	
	ブーム角 (°)	荷重 (ton)	ブーム角 (°)	荷重 (ton)	ブーム角 (°)	荷重 (ton)	ブーム角 (°)	荷重 (ton)	ブーム角 (°)	荷重 (ton)
10.0	79.0	24.0								
11.0	78.1	24.0	79.8	24.0						
12.0	77.1	24.0	78.8	24.0						
14.0	75.1	24.0	76.8	24.0	79.1	24.0				
16.0	73.0	24.0	74.7	24.0	77.0	24.0	78.5	21.4	79.6	19.9
18.0	70.7	20.1	72.5	21.2	74.7	22.7	76.2	20.6	77.1	19.4
20.0	68.2	16.0	70.0	16.9	72.2	18.2	73.8	19.1	74.6	19.1
22.0	65.8	12.7	67.5	13.6	69.6	14.6	71.1	15.4	71.9	15.8
24.0	63.3	10.2	65.0	10.9	67.0	11.8	68.4	12.4	69.0	12.8
26.0	60.7	8.0	62.3	8.7	64.3	9.5	65.6	10.0	66.0	10.2
28.0	58.0	5.7	59.7	6.5	61.6	7.4	62.7	7.9	63.0	8.1
30.0	55.3	3.7	56.9	4.4	58.7	5.3	59.8	5.8		
32.0					55.7	3.4	56.6	3.8		
掛数	2		2		2		2		2	
危険角度(°)	53		53		53		53		60	
フック種類	24t		24t		24t		24t		24t	
フック質量(t)	0.88		0.88		0.88		0.88		0.88	

SD性能

45.5mブーム+2m+10mスーパーラフィングジブ

オフセット 作業半径 (m)	5°		15°		30°		45°		60°	
	ブーム角 (°)	荷重 (ton)	ブーム角 (°)	荷重 (ton)	ブーム角 (°)	荷重 (ton)	ブーム角 (°)	荷重 (ton)	ブーム角 (°)	荷重 (ton)
11.0	79.4	24.0								
12.0	78.5	24.0								
14.0	76.8	24.0	78.3	24.0						
16.0	75.0	24.0	76.6	24.0	78.6	24.0				
18.0	72.9	20.0	74.5	21.1	76.6	22.1	78.0	19.8	78.8	18.6
20.0	70.7	15.9	72.2	16.9	74.3	18.2	75.8	18.5	76.5	17.5
22.0	68.4	12.7	70.0	13.5	72.0	14.6	73.5	15.5	74.2	15.9
24.0	66.2	10.1	67.7	10.8	69.6	11.8	71.0	12.5	71.6	12.9
26.0	63.8	7.9	65.4	8.6	67.3	9.5	68.5	10.0	69.0	10.3
28.0	61.4	5.6	63.0	6.4	64.8	7.5	66.0	8.0	66.4	8.2
30.0			60.5	4.4	62.2	5.3	63.3	5.9	63.6	6.1
32.0							60.6	3.9		
掛数	2		2		2		2		2	
危険角度(°)	58		58		58		58		60	
フック種類	24t		24t		24t		24t		24t	
フック質量(t)	0.88		0.88		0.88		0.88		0.88	

SD性能

50.0mブーム+2m+10mスーパーラフィングジブ

オフセット 作業半径 (m)	5°		15°		30°		45°		60°	
	ブーム角 (°)	荷重 (ton)	ブーム角 (°)	荷重 (ton)	ブーム角 (°)	荷重 (ton)	ブーム角 (°)	荷重 (ton)	ブーム角 (°)	荷重 (ton)
12.0	79.5	20.0								
14.0	77.9	20.0	79.4	20.0						
16.0	76.4	20.0	77.8	20.0	79.7	20.0				
18.0	74.7	19.9	76.2	20.0	78.0	20.0	79.4	19.6		
20.0	72.7	15.8	74.2	16.8	76.2	18.1	77.5	18.0	78.2	17.1
22.0	70.7	12.6	72.1	13.5	74.0	14.6	75.4	15.5	76.2	15.9
24.0	68.5	10.0	70.0	10.8	71.9	11.8	73.2	12.5	73.8	12.9
26.0	66.5	7.8	67.9	8.6	69.7	9.4	70.9	10.1	71.5	10.4
28.0	64.2	5.5	65.7	6.4	67.4	7.5	68.6	8.0	69.0	8.3
30.0					65.1	5.3	66.2	5.9	66.6	6.2
掛数	2		2		2		2		2	
危険角度(°)	62		62		62		62		63	
フック種類	24t		24t		24t		24t		24t	
フック質量(t)	0.88		0.88		0.88		0.88		0.88	

SD性能

40.9mブーム+2m+15mスーパーラフィングジブ

オフセット 作業半径 (m)	5°		15°		30°		45°		60°	
	ブーム角 (°)	荷重 (ton)	ブーム角 (°)	荷重 (ton)	ブーム角 (°)	荷重 (ton)	ブーム角 (°)	荷重 (ton)	ブーム角 (°)	荷重 (ton)
11.0	79.3	12.0								
12.0	78.3	12.0								
14.0	76.5	12.0	78.9	12.0						
16.0	74.6	12.0	77.0	12.0						
18.0	72.7	12.0	75.1	12.0	78.3	12.0				
20.0	70.8	12.0	73.2	12.0	76.3	12.0	78.8	12.0		
22.0	68.8	12.0	71.2	12.0	74.3	12.0	76.7	12.0	78.2	12.0
24.0	66.8	11.8	69.2	12.0	72.2	12.0	74.4	12.0	75.9	12.0
26.0	64.5	9.6	66.9	10.6	70.0	11.9	72.2	12.0	73.4	12.0
28.0	62.2	7.8	64.5	8.7	67.5	9.8	69.7	10.6	70.8	11.1
30.0	59.8	5.9	62.2	7.0	65.0	8.0	67.0	8.7	67.9	9.1
32.0	57.3	4.1	59.6	5.1	62.4	6.4	64.3	7.1	64.9	7.4
34.0	54.8	2.6	57.0	3.5	59.7	4.6	61.5	5.4		
36.0					56.9	3.1	58.5	3.7		
38.0							55.3	2.2		
掛数	1		1		1		1		1	
危険角度(°)	52		53		53		53		60	
フック種類	12t		12t		12t		12t		12t	
フック質量(t)	0.42		0.42		0.42		0.42		0.42	

SD性能

45.5mブーム+2m+15mスーパーラフィングジブ

オフセット 作業半径 (m)	5°		15°		30°		45°		60°	
	ブーム角 (°)	荷重 (ton)	ブーム角 (°)	荷重 (ton)	ブーム角 (°)	荷重 (ton)	ブーム角 (°)	荷重 (ton)	ブーム角 (°)	荷重 (ton)
14.0	77.8	12.0								
16.0	76.1	12.0	78.4	12.0						
18.0	74.4	12.0	76.6	12.0						
20.0	72.8	12.0	74.9	12.0	77.8	12.0				
22.0	71.0	12.0	73.2	12.0	76.0	12.0	78.2	12.0		
24.0	69.2	11.7	71.4	12.0	74.2	12.0	76.2	12.0	77.6	12.0
26.0	67.2	9.5	69.3	10.5	72.2	11.8	74.2	12.0	75.4	11.7
28.0	65.0	7.7	67.2	8.6	70.0	9.7	72.1	10.6	73.1	11.2
30.0	62.8	5.7	65.0	6.8	67.7	8.0	69.7	8.7	70.6	9.2
32.0	60.5	3.9	62.7	5.0	65.5	6.3	67.2	7.1	68.0	7.5
34.0			60.4	3.4	63.0	4.6	64.7	5.4	65.3	5.8
36.0					60.5	3.0	62.1	3.8	62.5	4.0
掛数	1		1		1		1		1	
危険角度(°)	57		58		58		58		60	
フック種類	12t		12t		12t		12t		12t	
フック質量(t)	0.42		0.42		0.42		0.42		0.42	

SD性能

50.0mブーム+2m+15mスーパーラフィングジブ

オフセット 作業半径 (m)	5°		15°		30°		45°		60°	
	ブーム角 (°)	荷重 (ton)	ブーム角 (°)	荷重 (ton)	ブーム角 (°)	荷重 (ton)	ブーム角 (°)	荷重 (ton)	ブーム角 (°)	荷重 (ton)
14.0	78.9	12.0								
16.0	77.4	12.0	79.4	12.0						
18.0	76.0	12.0	78.0	12.0						
20.0	74.5	12.0	76.4	12.0	79.1	12.0				
22.0	72.9	12.0	74.9	12.0	77.5	12.0	79.6	12.0		
24.0	71.3	11.6	73.3	12.0	75.9	12.0	77.8	12.0	79.1	12.0
26.0	69.3	9.4	71.5	10.4	74.1	11.8	76.1	12.0	77.1	11.5
28.0	67.4	7.5	69.4	8.5	72.2	9.7	74.1	10.6	75.2	10.9
30.0	65.3	5.5	67.4	6.7	70.1	7.9	71.9	8.8	72.9	9.2
32.0	63.2	3.8	65.3	4.9	67.9	6.3	69.8	7.1	70.6	7.5
34.0					65.7	4.5	67.5	5.5	68.2	5.9
36.0							65.0	3.8	65.6	4.1
掛数	1		1		1		1		1	
危険角度(°)	61		62		62		62		62	
フック種類	12t		12t		12t		12t		12t	
フック質量(t)	0.42		0.42		0.42		0.42		0.42	

SD性能

40.9mブーム+2m+19mスーパーラフィングジブ

オフセット	5°		15°		30°		45°		60°	
作業半径 (m)	ブーム角 (°)	荷重 (ton)	ブーム角 (°)	荷重 (ton)	ブーム角 (°)	荷重 (ton)	ブーム角 (°)	荷重 (ton)	ブーム角 (°)	荷重 (ton)
12.0	79.5	12.0								
14.0	77.8	12.0								
16.0	76.1	12.0	79.0	12.0						
18.0	74.4	12.0	77.3	12.0						
20.0	72.7	12.0	75.5	12.0	79.4	12.0				
22.0	70.9	12.0	73.7	12.0	77.4	12.0				
24.0	69.1	12.0	71.8	12.0	75.5	12.0	78.4	10.4		
26.0	67.0	10.5	69.9	11.7	73.6	11.6	76.2	10.2	78.0	9.1
28.0	64.8	8.7	67.7	9.8	71.5	11.1	74.0	9.9	75.7	9.0
30.0	62.7	7.1	65.5	8.1	69.2	9.4	71.8	9.7	73.2	8.9
32.0	60.4	5.4	63.2	6.6	66.8	7.8	69.4	8.7	70.7	8.8
34.0	58.1	3.9	60.9	5.0	64.3	6.4	66.8	7.2	67.8	7.6
36.0	55.6	2.5	58.4	3.6	61.8	4.9	64.2	5.9	64.9	6.2
38.0					59.2	3.5	61.3	4.3		
40.0					56.5	2.2	58.3	2.9		
掛数	1		1		1		1		1	
危険角度(°)	53		54		54		54		60	
フック種類	12t		12t		12t		12t		12t	
フック質量(t)	0.42		0.42		0.42		0.42		0.42	

SD性能

45.5mブーム+2m+19mスーパーラフィングジブ

オフセット	5°		15°		30°		45°		60°	
作業半径 (m)	ブーム角 (°)	荷重 (ton)	ブーム角 (°)	荷重 (ton)	ブーム角 (°)	荷重 (ton)	ブーム角 (°)	荷重 (ton)	ブーム角 (°)	荷重 (ton)
14.0	79.0	12.0								
16.0	77.4	12.0								
18.0	75.9	12.0	78.5	12.0						
20.0	74.3	12.0	77.0	12.0						
22.0	72.8	12.0	75.3	12.0	78.9	12.0				
24.0	71.1	12.0	73.7	12.0	77.1	12.0	79.7	10.6		
26.0	69.2	10.4	72.0	11.6	75.4	11.9	77.9	10.3	79.5	9.2
28.0	67.3	8.5	69.9	9.6	73.5	11.1	76.0	10.1	77.4	9.1
30.0	65.3	6.9	68.0	8.0	71.4	9.3	74.0	9.6	75.3	9.0
32.0	63.2	5.1	65.9	6.4	69.3	7.7	71.8	8.7	73.0	8.6
34.0	61.1	3.6	63.7	4.8	67.1	6.4	69.4	7.2	70.6	7.7
36.0			61.5	3.4	64.7	4.8	67.0	5.9	68.0	6.3
38.0					62.4	3.4	64.6	4.3	65.3	4.7
40.0							62.0	2.9	62.5	3.2
掛数	1		1		1		1		1	
危険角度(°)	58		59		59		59		60	
フック種類	12t		12t		12t		12t		12t	
フック質量(t)	0.42		0.42		0.42		0.42		0.42	

SD性能

50.0mブーム+2m+19mスーパーラフィングジブ

オフセット	5°		15°		30°		45°		60°	
作業半径 (m)	ブーム角 (°)	荷重 (ton)	ブーム角 (°)	荷重 (ton)	ブーム角 (°)	荷重 (ton)	ブーム角 (°)	荷重 (ton)	ブーム角 (°)	荷重 (ton)
16.0	78.6	12.0								
18.0	77.2	12.0	79.7	12.0						
20.0	75.8	12.0	78.3	12.0						
22.0	74.4	12.0	76.8	12.0	80.2	12.0				
24.0	73.0	12.0	75.4	12.0	78.6	12.0				
26.0	71.2	10.2	73.8	11.5	77.1	11.9	79.3	10.4		
28.0	69.4	8.4	72.0	9.5	75.3	11.0	77.6	10.0	78.9	9.1
30.0	67.5	6.7	70.0	7.8	73.4	9.2	75.7	9.4	77.0	8.9
32.0	65.6	4.9	68.1	6.3	71.4	7.7	73.8	8.7	75.0	8.4
34.0			66.1	4.6	69.3	6.3	71.7	7.2	72.9	7.7
36.0			64.1	3.2	67.3	4.7	69.5	5.9	70.6	6.3
38.0					65.1	3.3	67.2	4.3	68.2	4.8
40.0									65.6	3.3
掛数	1		1		1		1		1	
危険角度(°)	62		62		63		63		63	
フック種類	12t		12t		12t		12t		12t	
フック質量(t)	0.42		0.42		0.42		0.42		0.42	

SD性能

40.9mブーム+2m+23mスーパーラフィングジブ

オフセット 作業半径 (m)	5°		15°		30°		45°		60°	
	ブーム角 (°)	荷重 (ton)	ブーム角 (°)	荷重 (ton)	ブーム角 (°)	荷重 (ton)	ブーム角 (°)	荷重 (ton)	ブーム角 (°)	荷重 (ton)
14.0	79.1	12.0								
16.0	77.5	12.0								
18.0	75.9	12.0	79.2	12.0						
20.0	74.3	12.0	77.6	12.0						
22.0	72.7	12.0	76.0	12.0	80.2	10.4				
24.0	71.0	12.0	74.2	11.5	78.4	10.1				
26.0	69.2	11.3	72.4	10.9	76.5	9.8	79.9	8.1		
28.0	67.2	9.5	70.5	10.3	74.6	9.4	77.8	7.8		
30.0	65.2	7.9	68.5	9.0	72.6	9.0	75.7	7.6	77.9	6.8
32.0	63.1	6.5	66.4	7.6	70.6	8.7	73.6	7.5	75.5	6.7
34.0	61.0	4.9	64.2	6.3	68.5	7.6	71.4	7.3	73.1	6.7
36.0	58.7	3.6	62.0	4.8	66.2	6.3	69.2	7.1	70.5	6.6
38.0	56.4	2.4	59.7	3.5	63.8	5.1	66.6	6.1	67.9	6.5
40.0			57.3	2.4	61.2	3.8	64.0	4.8	65.0	5.3
42.0					58.7	2.6	61.2	3.5		
44.0							58.3	2.2		
掛数	1		1		1		1		1	
危険角度(°)	54		55		55		55		60	
フック種類	12t		12t		12t		12t		12t	
フック質量(t)	0.42		0.42		0.42		0.42		0.42	

SD性能

45.5mブーム+2m+23mスーパーラフィングジブ

オフセット 作業半径 (m)	5°		15°		30°		45°		60°	
	ブーム角 (°)	荷重 (ton)	ブーム角 (°)	荷重 (ton)	ブーム角 (°)	荷重 (ton)	ブーム角 (°)	荷重 (ton)	ブーム角 (°)	荷重 (ton)
16.0	78.7	12.0								
18.0	77.2	12.0								
20.0	75.8	12.0	78.9	12.0						
22.0	74.3	12.0	77.4	12.0						
24.0	72.9	12.0	75.9	12.0	79.7	10.2				
26.0	71.2	11.1	74.2	11.3	78.0	9.9				
28.0	69.3	9.3	72.5	10.6	76.3	9.6	79.2	7.9		
30.0	67.5	7.7	70.6	8.9	74.6	9.3	77.4	7.7	79.3	6.9
32.0	65.6	6.2	68.7	7.4	72.7	8.9	75.5	7.6	77.2	6.8
34.0	63.5	4.6	66.7	6.1	70.7	7.5	73.5	7.4	75.1	6.7
36.0	61.5	3.3	64.6	4.6	68.6	6.3	71.6	7.2	72.9	6.6
38.0			62.5	3.3	66.4	4.9	69.3	6.0	70.6	6.5
40.0					64.2	3.6	66.9	4.8	68.1	5.4
42.0							64.4	3.4	65.3	3.9
44.0									62.5	2.6
掛数	1		1		1		1		1	
危険角度(°)	59		59		60		60		60	
フック種類	12t		12t		12t		12t		12t	
フック質量(t)	0.42		0.42		0.42		0.42		0.42	

SD性能

50.0mブーム+2m+23mスーパーラフィングジブ

オフセット 作業半径 (m)	5°		15°		30°		45°		60°	
	ブーム角 (°)	荷重 (ton)	ブーム角 (°)	荷重 (ton)	ブーム角 (°)	荷重 (ton)	ブーム角 (°)	荷重 (ton)	ブーム角 (°)	荷重 (ton)
16.0	79.6	11.0								
18.0	78.3	11.0								
20.0	77.0	11.0	79.8	11.0						
22.0	75.7	11.0	78.5	11.0						
24.0	74.4	11.0	77.2	11.0						
26.0	73.0	10.9	75.8	11.0	79.3	10.1				
28.0	71.3	9.1	74.3	10.4	77.8	9.8				
30.0	69.5	7.5	72.5	8.7	76.3	9.4	78.8	7.8		
32.0	67.7	5.9	70.7	7.3	74.6	8.7	77.1	7.7	78.7	6.8
34.0	65.8	4.4	68.9	5.9	72.7	7.4	75.4	7.5	76.9	6.7
36.0			66.9	4.4	70.7	6.2	73.5	7.0	74.9	6.7
38.0					68.7	4.8	71.4	6.0	72.8	6.4
40.0					66.7	3.5	69.3	4.7	70.6	5.4
42.0							67.0	3.4	68.1	4.0
掛数	1		1		1		1		1	
危険角度(°)	63		63		64		64		64	
フック種類	12t		12t		12t		12t		12t	
フック質量(t)	0.42		0.42		0.42		0.42		0.42	

SD性能

40.9mブーム+2m+27mスーパーラフィングジブ

オフセット 作業半径 (m)	5°		15°		30°		45°		60°	
	ブーム角 (°)	荷重 (ton)	ブーム角 (°)	荷重 (ton)	ブーム角 (°)	荷重 (ton)	ブーム角 (°)	荷重 (ton)	ブーム角 (°)	荷重 (ton)
14.0	80.3	12.0								
16.0	78.9	12.0								
18.0	77.4	12.0								
20.0	75.9	12.0	79.5	11.2						
22.0	74.4	12.0	77.9	10.7						
24.0	72.8	11.4	76.2	10.2						
26.0	71.1	10.6	74.5	9.6	79.2	7.9				
28.0	69.4	9.9	72.8	9.1	77.4	7.6				
30.0	67.6	8.6	71.1	8.6	75.7	7.4	79.4	6.3		
32.0	65.6	7.2	69.3	8.1	73.8	7.2	77.4	6.1	80.0	5.4
34.0	63.6	5.9	67.4	7.1	71.9	7.0	75.4	6.0	77.7	5.3
36.0	61.5	4.5	65.3	6.0	70.0	6.8	73.3	5.8	75.4	5.2
38.0	59.4	3.3	63.1	4.7	67.9	6.2	71.1	5.7	73.0	5.2
40.0	57.3	2.3	60.9	3.5	65.6	5.2	68.9	5.5	70.4	5.1
42.0			58.7	2.4	63.3	4.0	66.5	5.1	67.9	5.1
44.0					60.8	2.9	63.9	3.9	65.0	4.4
46.0					58.3	1.9	61.1	2.8		
48.0							58.2	1.7		
掛数	1		1		1		1		1	
危険角度(°)	55		56		56		56		60	
フック種類	12t		12t		12t		12t		12t	
フック質量(t)	0.42		0.42		0.42		0.42		0.42	

SD性能

45.5mブーム+2m+27mスーパーラフィングジブ

オフセット 作業半径 (m)	5°		15°		30°		45°		60°	
	ブーム角 (°)	荷重 (ton)	ブーム角 (°)	荷重 (ton)	ブーム角 (°)	荷重 (ton)	ブーム角 (°)	荷重 (ton)	ブーム角 (°)	荷重 (ton)
16.0	79.8	11.0								
18.0	78.4	11.0								
20.0	77.1	11.0	80.5	11.0						
22.0	75.7	11.0	79.2	10.9						
24.0	74.3	11.0	77.6	10.4						
26.0	73.0	11.0	76.2	10.0	80.3	8.0				
28.0	71.3	9.9	74.6	9.4	78.8	7.8				
30.0	69.5	8.3	73.0	8.9	77.1	7.5				
32.0	67.8	7.0	71.3	8.2	75.5	7.3	78.8	6.2		
34.0	65.8	5.6	69.5	6.9	73.8	7.1	76.9	6.0	79.2	5.3
36.0	64.0	4.2	67.6	5.7	72.1	7.0	75.2	5.9	77.1	5.3
38.0	62.0	3.0	65.6	4.4	70.1	6.1	73.3	5.8	75.0	5.2
40.0			63.5	3.2	68.1	5.0	71.3	5.6	72.8	5.1
42.0					65.9	3.8	69.2	5.1	70.6	5.1
44.0					63.7	2.7	66.8	3.9	68.0	4.5
46.0							64.3	2.7	65.3	3.2
掛数	1		1		1		1		1	
危険角度(°)	60		60		61		61		61	
フック種類	12t		12t		12t		12t		12t	
フック質量(t)	0.42		0.42		0.42		0.42		0.42	

SD性能

50.0mブーム+2m+27mスーパーラフィングジブ

オフセット 作業半径 (m)	5°		15°		30°		45°		60°	
	ブーム角 (°)	荷重 (ton)	ブーム角 (°)	荷重 (ton)	ブーム角 (°)	荷重 (ton)	ブーム角 (°)	荷重 (ton)	ブーム角 (°)	荷重 (ton)
18.0	79.1	9.0								
20.0	77.9	9.0								
22.0	76.7	9.0	79.9	9.0						
24.0	75.4	9.0	78.6	9.0						
26.0	74.1	9.0	77.3	9.0						
28.0	72.9	9.0	76.0	9.0	80.0	7.9				
30.0	71.4	8.1	74.7	8.9	78.5	7.6				
32.0	69.7	6.8	73.1	8.1	77.0	7.4	80.1	6.3		
34.0	67.9	5.3	71.3	6.8	75.5	7.3	78.4	6.1		
36.0	66.1	3.9	69.6	5.5	73.9	7.0	76.8	6.0	78.6	5.3
38.0			67.7	4.2	72.1	6.0	75.0	5.8	76.7	5.2
40.0					70.2	4.9	73.3	5.7	74.8	5.2
42.0					68.2	3.7	71.3	5.0	72.8	5.1
44.0					66.1	2.6	69.1	3.8	70.6	4.6
46.0									68.1	3.3
掛数	1		1		1		1		1	
危険角度(°)	63		64		64		65		65	
フック種類	12t		12t		12t		12t		12t	
フック質量(t)	0.42		0.42		0.42		0.42		0.42	

SD性能

40.9mブーム+2m+31mスーパーラフィングジブ

オフセット 作業半径 (m)	5°		15°		30°		45°		60°	
	ブーム角 (°)	荷重 (ton)	ブーム角 (°)	荷重 (ton)	ブーム角 (°)	荷重 (ton)	ブーム角 (°)	荷重 (ton)	ブーム角 (°)	荷重 (ton)
16.0	79.7	9.0								
18.0	78.3	9.0								
20.0	76.9	9.0								
22.0	75.5	9.0	79.6	9.0						
24.0	74.1	9.0	78.1	8.7						
26.0	72.7	9.0	76.5	8.3						
28.0	71.2	8.9	74.9	8.0	80.0	6.4				
30.0	69.6	8.3	73.3	7.6	78.4	6.2				
32.0	67.9	7.8	71.7	7.3	76.7	6.1				
34.0	66.1	6.6	70.0	6.9	74.9	5.9	79.0	4.9		
36.0	64.1	5.4	68.3	6.6	73.2	5.7	77.0	4.8		
38.0	62.1	4.2	66.3	5.7	71.2	5.5	75.1	4.7	77.7	4.2
40.0	60.1	3.1	64.2	4.5	69.4	5.3	73.1	4.6	75.4	4.2
42.0	58.0	2.1	62.1	3.4	67.5	5.1	70.9	4.5	73.0	4.1
44.0			59.9	2.5	65.2	4.1	68.8	4.4	70.5	4.1
46.0					62.9	3.1	66.5	4.3	67.8	4.0
48.0					60.4	2.1	63.8	3.2	64.9	3.8
50.0							61.0	2.2		
掛数	1		1		1		1		1	
危険角度(°)	56		57		57		57		60	
フック種類	12t		12t		12t		12t		12t	
フック質量(t)	0.42		0.42		0.42		0.42		0.42	

SD性能

45.5mブーム+2m+31mスーパーラフィングジブ

オフセット 作業半径 (m)	5°		15°		30°		45°		60°	
	ブーム角 (°)	荷重 (ton)	ブーム角 (°)	荷重 (ton)	ブーム角 (°)	荷重 (ton)	ブーム角 (°)	荷重 (ton)	ブーム角 (°)	荷重 (ton)
18.0	79.3	9.0								
20.0	78.0	9.0								
22.0	76.8	9.0	80.6	9.0						
24.0	75.5	9.0	79.3	9.0						
26.0	74.2	9.0	77.8	8.5						
28.0	72.9	9.0	76.4	8.2						
30.0	71.5	8.8	74.9	7.8	79.6	6.3				
32.0	69.8	7.6	73.5	7.5	78.0	6.1				
34.0	68.1	6.4	72.0	7.2	76.4	6.0	80.2	5.0		
36.0	66.2	5.0	70.3	6.5	74.9	5.8	78.5	4.9		
38.0	64.4	3.8	68.4	5.4	73.2	5.6	76.6	4.7	79.1	4.2
40.0	62.5	2.7	66.4	4.2	71.5	5.4	74.8	4.6	77.1	4.2
42.0			64.5	3.1	69.7	5.0	72.9	4.5	75.0	4.1
44.0					67.6	3.9	71.1	4.5	72.7	4.1
46.0					65.5	2.9	69.1	4.2	70.5	4.0
48.0							66.6	3.1	68.1	3.8
50.0							64.2	2.2	65.3	2.7
掛数	1		1		1		1		1	
危険角度(°)	60		61		62		62		62	
フック種類	12t		12t		12t		12t		12t	
フック質量(t)	0.42		0.42		0.42		0.42		0.42	

SD性能

50.0mブーム+2m+31mスーパーラフィングジブ

オフセット 作業半径 (m)	5°		15°		30°		45°		60°	
	ブーム角 (°)	荷重 (ton)	ブーム角 (°)	荷重 (ton)	ブーム角 (°)	荷重 (ton)	ブーム角 (°)	荷重 (ton)	ブーム角 (°)	荷重 (ton)
18.0	80.0	8.0								
20.0	78.8	8.0								
22.0	77.7	8.0								
24.0	76.6	8.0	80.1	8.0						
26.0	75.4	8.0	78.9	8.0						
28.0	74.1	8.0	77.7	8.0						
30.0	72.9	8.0	76.5	8.0	80.6	6.4				
32.0	71.5	7.3	75.0	7.7	79.3	6.2				
34.0	69.9	6.1	73.7	7.4	77.8	6.1				
36.0	68.2	4.7	72.0	6.3	76.4	5.9	79.7	4.9		
38.0	66.4	3.5	70.3	5.2	74.8	5.7	78.1	4.8		
40.0			68.5	4.0	73.4	5.5	76.5	4.7	78.6	4.2
42.0			66.6	2.9	71.6	4.9	74.8	4.6	76.7	4.1
44.0					69.7	3.8	73.1	4.5	74.8	4.1
46.0					67.7	2.7	71.2	4.1	72.8	4.1
48.0							69.0	3.1	70.6	3.8
50.0									68.2	2.7
掛数	1		1		1		1		1	
危険角度(°)	64		64		65		65		65	
フック種類	12t		12t		12t		12t		12t	
フック質量(t)	0.42		0.42		0.42		0.42		0.42	

HA性能

13.6mブーム+4.4m+13mヘビーリフトジブ

オフセット	10°	20°	30°	45°	60°
作業半径 (m)	荷重 (ton)	荷重 (ton)	荷重 (ton)	荷重 (ton)	荷重 (ton)
7.0	84.0				
8.0	84.0	84.0			
9.0	84.0	80.1			
10.0	80.8	76.0	65.8		
11.0	75.6	72.2	63.2		
12.0	70.0	68.9	60.7	50.9	
14.0	60.9	61.6	56.6	48.1	34.2
16.0	53.9	54.5	53.1	45.8	33.3
18.0	48.3	48.7	49.3	44.0	32.7
20.0	42.4	43.1	43.7	42.6	
22.0	37.5	38.0	38.5	38.9	
24.0	33.4	33.8	34.1		
26.0	30.0	30.2	30.3		
28.0	27.0				
掛数	8	8	8	8	8
危険角度 (°)	10	20	30	45	60
フック種類	150t	150t	150t	150t	150t
フック質量 (t)	1.86	1.86	1.86	1.86	1.86

HA性能

22.7mブーム+4.4m+13mヘビーリフトジブ

オフセット	10°	20°	30°	45°	60°
作業半径 (m)	荷重 (ton)	荷重 (ton)	荷重 (ton)	荷重 (ton)	荷重 (ton)
8.0	64.0				
9.0	64.0				
10.0	64.0	64.0			
11.0	64.0	64.0			
12.0	64.0	64.0	64.0		
14.0	60.9	62.6	61.2	51.8	
16.0	52.2	53.6	55.0	49.8	38.6
18.0	44.7	46.1	47.3	48.2	37.8
20.0	38.7	39.8	40.9	42.1	37.3
22.0	33.7	34.7	35.6	36.6	36.9
24.0	29.6	30.4	31.1	32.0	
26.0	26.1	26.8	27.4	28.0	
28.0	23.1	23.7	24.2	24.6	
30.0	20.5	21.0	21.3		
32.0	18.3	18.6	18.9		
34.0	16.3	16.5	16.6		
36.0	14.5	14.6			
掛数	6	6	6	6	6
危険角度 (°)	10	20	30	45	60
フック種類	83t	83t	83t	83t	83t
フック質量 (t)	1.00	1.00	1.00	1.00	1.00

HA性能

18.15mブーム+4.4m+13mヘビーリフトジブ

オフセット	10°	20°	30°	45°	60°
作業半径 (m)	荷重 (ton)	荷重 (ton)	荷重 (ton)	荷重 (ton)	荷重 (ton)
7.0	77.0				
8.0	77.0				
9.0	77.0	77.0			
10.0	77.0	77.0			
11.0	77.0	76.2	65.2		
12.0	73.4	72.9	63.0		
14.0	62.2	63.6	59.0	50.6	
16.0	53.6	54.8	55.6	48.4	36.2
18.0	46.2	47.4	48.4	46.5	35.5
20.0	40.2	41.1	42.0	43.0	35.1
22.0	35.3	36.0	36.7	37.5	
24.0	31.2	31.8	32.3	32.9	
26.0	27.7	28.2	28.6	28.9	
28.0	24.7	25.1	25.4		
30.0	22.2	22.4	22.5		
32.0	19.9				
掛数	8	8	8	8	8
危険角度 (°)	10	20	30	45	60
フック種類	150t	150t	150t	150t	150t
フック質量 (t)	1.86	1.86	1.86	1.86	1.86

HA性能

31.8mブーム+4.4m+13mヘビーリフトジブ

オフセット	10°	20°	30°	45°	60°
作業半径 (m)	荷重 (ton)	荷重 (ton)	荷重 (ton)	荷重 (ton)	荷重 (ton)
10.0	45.0				
11.0	44.8	40.3			
12.0	44.1	39.8			
14.0	42.8	38.8	35.3		
16.0	41.7	38.0	34.7	30.2	
18.0	40.7	37.2	34.1	29.8	25.8
20.0	37.0	36.6	33.7	29.6	25.8
22.0	33.2	34.0	33.3	29.5	25.8
24.0	29.4	30.4	31.2	29.4	25.8
26.0	25.9	26.7	27.5	28.3	25.8
28.0	22.9	23.6	24.3	25.0	25.3
30.0	20.3	20.9	21.5	22.1	
32.0	18.0	18.6	19.1	19.5	
34.0	16.0	16.5	16.9	17.2	
36.0	14.2	14.6	15.0		
38.0	12.6	13.0	13.2		
40.0	11.2	11.5	11.6		
42.0	9.9	10.1			
44.0	8.7	8.8			
46.0	7.4				
掛数	4	4	4	4	4
危険角度 (°)	10	20	30	45	60
フック種類	83t	83t	83t	83t	83t
フック質量 (t)	1.00	1.00	1.00	1.00	1.00

HA性能

13.6mブーム+4.4m+22mヘビーリフトジブ

オフセット	10°	20°	30°	45°	60°
作業半径 (m)	荷重 (ton)	荷重 (ton)	荷重 (ton)	荷重 (ton)	荷重 (ton)
10.0	54.0				
11.0	54.0				
12.0	54.0				
14.0	54.0	47.4			
16.0	49.9	43.1	38.0		
18.0	45.0	39.5	35.3		
20.0	41.1	36.6	33.0	28.1	
22.0	37.7	34.0	31.0	26.8	19.4
24.0	34.9	31.8	29.3	25.7	18.9
26.0	31.9	30.0	27.9	24.7	18.6
28.0	28.9	28.3	26.6	23.9	18.4
30.0	26.3	26.7	25.6	23.4	
32.0	23.9	24.2	24.6	23.1	
34.0	21.8	22.1	22.3		
36.0	20.0	20.1			
掛数	6	6	6	6	6
危険角度 (°)	10	20	30	45	60
フック種類	83t	83t	83t	83t	83t
フック質量 (t)	1.00	1.00	1.00	1.00	1.00

HA性能

22.7mブーム+4.4m+22mヘビーリフトジブ

オフセット	10°	20°	30°	45°	60°
作業半径 (m)	荷重 (ton)	荷重 (ton)	荷重 (ton)	荷重 (ton)	荷重 (ton)
11.0	45.0				
12.0	45.0				
14.0	45.0				
16.0	45.0	45.0			
18.0	45.0	45.0	39.5		
20.0	41.4	43.0	37.2		
22.0	36.4	38.1	35.2	30.0	
24.0	32.2	33.7	33.4	28.9	22.1
26.0	28.6	29.9	31.2	27.9	21.7
28.0	25.6	26.7	27.8	27.0	21.3
30.0	22.9	23.9	24.9	26.1	21.1
32.0	20.6	21.5	22.3	23.4	20.9
34.0	18.6	19.3	20.1	20.9	
36.0	16.7	17.4	18.0	18.7	
38.0	15.1	15.7	16.2	16.6	
40.0	13.6	14.1	14.5		
42.0	12.3	12.7	12.9		
44.0	11.1	11.3			
46.0	10.0				
掛数	4	4	4	4	4
危険角度 (°)	10	20	30	45	60
フック種類	83t	83t	83t	83t	83t
フック質量 (t)	1.00	1.00	1.00	1.00	1.00

HA性能

18.15mブーム+4.4m+22mヘビーリフトジブ

オフセット	10°	20°	30°	45°	60°
作業半径 (m)	荷重 (ton)	荷重 (ton)	荷重 (ton)	荷重 (ton)	荷重 (ton)
10.0	50.0				
11.0	50.0				
12.0	50.0				
14.0	50.0	49.4			
16.0	50.0	45.2			
18.0	48.8	41.7	36.4		
20.0	42.7	38.7	34.3		
22.0	37.7	36.2	32.3	28.2	
24.0	33.5	33.9	30.7	27.1	20.6
26.0	29.9	31.0	29.2	26.2	20.2
28.0	26.9	27.8	27.9	25.4	19.9
30.0	24.3	25.1	25.9	24.7	19.7
32.0	22.0	22.7	23.3	24.0	
34.0	20.0	20.6	21.1	21.5	
36.0	18.2	18.7	19.0		
38.0	16.6	16.9	17.2		
40.0	15.1	15.4			
42.0	12.1				
掛数	6	6	6	6	6
危険角度 (°)	10	20	30	45	60
フック種類	83t	83t	83t	83t	83t
フック質量 (t)	1.00	1.00	1.00	1.00	1.00

HA性能

31.8mブーム+4.4m+22mヘビーリフトジブ

オフセット	10°	20°	30°	45°	60°
作業半径 (m)	荷重 (ton)	荷重 (ton)	荷重 (ton)	荷重 (ton)	荷重 (ton)
14.0	30.0				
16.0	30.0	29.8			
18.0	30.0	28.9			
20.0	30.0	28.0	25.2		
22.0	30.0	27.3	24.6		
24.0	29.2	26.6	24.1	20.6	
26.0	27.8	26.0	23.7	20.3	17.0
28.0	24.8	25.5	23.3	20.1	16.9
30.0	22.1	23.3	22.9	19.9	16.9
32.0	19.8	20.9	21.9	19.7	16.9
34.0	17.8	18.8	19.7	19.7	16.9
36.0	16.0	16.9	17.6	18.6	16.9
38.0	14.3	15.1	15.8	16.6	
40.0	12.9	13.6	14.2	14.9	
42.0	11.6	12.2	12.7	13.2	
44.0	10.4	10.9	11.4	11.7	
46.0	9.3	9.7	10.1		
48.0	8.3	8.7	8.9		
50.0	7.4	7.7	7.8		
55.0	5.1				
掛数	4	4	4	4	4
危険角度 (°)	10	20	30	45	60
フック種類	83t	83t	83t	83t	83t
フック質量 (t)	1.00	1.00	1.00	1.00	1.00

HA性能

40.9mブーム+4.4m+22mヘビーリフトジブ

オフセット	10°	20°	30°	45°	60°
作業半径 (m)	荷重 (ton)	荷重 (ton)	荷重 (ton)	荷重 (ton)	荷重 (ton)
16.0	20.0				
18.0	20.0				
20.0	20.0	20.0			
22.0	20.0	20.0	20.0		
24.0	20.0	20.0	20.0		
26.0	20.0	20.0	20.0	20.0	
28.0	20.0	20.0	20.0	20.0	20.0
30.0	20.0	20.0	20.0	20.0	20.0
32.0	19.5	20.0	20.0	20.0	20.0
34.0	17.5	18.7	19.5	20.0	20.0
36.0	15.7	16.7	17.6	18.8	19.3
38.0	14.1	15.0	15.8	16.8	17.4
40.0	12.6	13.5	14.2	15.1	15.5
42.0	11.3	12.1	12.7	13.5	
44.0	10.1	10.8	11.4	12.0	
46.0	9.0	9.6	10.1	10.7	
48.0	8.0	8.5	9.0	9.4	
50.0	7.0	7.5	7.9	8.2	
55.0	5.0	5.3	5.6		
60.0	3.3	3.4			
掛数	2	2	2	2	2
危険角度 (°)	20	20	30	45	60
フック種類	24t	24t	24t	24t	24t
フック質量 (t)	0.88	0.88	0.88	0.88	0.88

HA性能

50.0mブーム+4.4m+22mヘビーリフトジブ

オフセット	10°	20°	30°	45°	60°
作業半径 (m)	荷重 (ton)	荷重 (ton)	荷重 (ton)	荷重 (ton)	荷重 (ton)
18.0	11.0				
20.0	11.0				
22.0	11.0	11.0			
24.0	11.0	11.0	11.0		
26.0	11.0	11.0	11.0		
28.0	11.0	11.0	10.9	9.1	
30.0	11.0	11.0	10.8	9.1	7.5
32.0	11.0	11.0	10.6	9.0	7.5
34.0	11.0	11.0	10.5	9.0	7.5
36.0	11.0	11.0	10.4	8.9	7.5
38.0	11.0	11.0	10.4	8.9	7.5
40.0	11.0	11.0	10.3	8.9	7.5
42.0	10.6	11.0	10.3	8.9	7.5
44.0	9.6	10.3	10.3	8.9	7.5
46.0	8.5	9.2	9.9	8.9	
48.0	7.5	8.2	8.8	8.9	
50.0	6.6	7.2	7.7	8.3	
55.0	4.5	5.0	5.4	5.8	
60.0	2.8	3.2	3.5		
掛数	2	2	2	2	2
危険角度 (°)	34	34	34	45	60
フック種類	24t	24t	24t	24t	24t
フック質量 (t)	0.88	0.88	0.88	0.88	0.88

HA性能

45.5mブーム+4.4m+22mヘビーリフトジブ

オフセット	10°	20°	30°	45°	60°
作業半径 (m)	荷重 (ton)	荷重 (ton)	荷重 (ton)	荷重 (ton)	荷重 (ton)
16.0	16.0				
18.0	16.0				
20.0	16.0	16.0			
22.0	16.0	16.0			
24.0	16.0	16.0	16.0		
26.0	16.0	16.0	16.0		
28.0	16.0	16.0	16.0	15.6	
30.0	16.0	16.0	16.0	15.4	13.0
32.0	16.0	16.0	16.0	15.3	13.0
34.0	16.0	16.0	16.0	15.2	12.9
36.0	15.5	16.0	16.0	15.1	12.9
38.0	13.8	14.8	15.7	15.1	12.9
40.0	12.4	13.3	14.1	15.0	12.9
42.0	11.0	11.9	12.6	13.4	12.9
44.0	9.8	10.6	11.2	12.0	
46.0	8.7	9.4	10.0	10.6	
48.0	7.7	8.3	8.9	9.4	
50.0	6.8	7.4	7.8	8.3	
55.0	4.7	5.2	5.5		
60.0	3.0	3.3	3.5		
掛数	2	2	2	2	2
危険角度 (°)	25	26	30	45	60
フック種類	24t	24t	24t	24t	24t
フック質量 (t)	0.88	0.88	0.88	0.88	0.88

HA性能

13.6mブーム+4.4m+31mヘビーリフトジブ

オフセット	10°	20°	30°	45°	60°
作業半径 (m)	荷重 (ton)	荷重 (ton)	荷重 (ton)	荷重 (ton)	荷重 (ton)
14.0	35.0				
16.0	34.4				
18.0	34.4	33.8			
20.0	34.4	31.5			
22.0	32.8	29.1	26.1		
24.0	30.2	27.1	24.5		
26.0	27.9	25.3	23.1		
28.0	26.0	23.7	21.8	18.8	
30.0	24.3	22.4	20.7	18.0	
32.0	22.8	21.2	19.7	17.3	12.7
34.0	21.5	20.1	18.9	16.7	12.4
36.0	20.3	19.1	18.1	16.2	12.2
38.0	19.3	18.3	17.4	15.8	
40.0	17.8	17.6	16.9	15.5	
42.0	16.5	16.8	16.4		
44.0	15.4	15.6	15.7		
46.0	14.3				
掛数	4	4	4	4	4
危険角度 (°)	10	20	30	45	60
フック種類	83t	83t	83t	83t	83t
フック質量 (t)	1.00	1.00	1.00	1.00	1.00

HA性能

22.7mブーム+4.4m+31mヘビーリフトジブ

オフセット	10°	20°	30°	45°	60°
作業半径 (m)	荷重 (ton)	荷重 (ton)	荷重 (ton)	荷重 (ton)	荷重 (ton)
16.0	30.0				
18.0	30.0				
20.0	30.0	30.0			
22.0	30.0	30.0			
24.0	30.0	29.6	25.8		
26.0	30.0	27.8	24.5		
28.0	27.0	26.2	23.3		
30.0	24.3	24.8	22.2	19.4	
32.0	22.0	23.3	21.3	18.7	
34.0	19.9	21.1	20.4	18.2	14.5
36.0	18.1	19.2	19.7	17.7	14.2
38.0	16.4	17.4	18.3	17.2	14.1
40.0	15.0	15.9	16.7	16.8	13.9
42.0	13.6	14.4	15.2	15.9	
44.0	12.4	13.1	13.8	14.5	
46.0	11.3	11.9	12.5	13.1	
48.0	10.3	10.8	11.3		
50.0	9.4	9.8	10.1		
55.0	7.3				
掛数	4	4	4	4	4
危険角度 (°)	10	20	30	45	60
フック種類	83t	83t	83t	83t	83t
フック質量 (t)	1.00	1.00	1.00	1.00	1.00

HA性能

18.15mブーム+4.4m+31mヘビーリフトジブ

オフセット	10°	20°	30°	45°	60°
作業半径 (m)	荷重 (ton)	荷重 (ton)	荷重 (ton)	荷重 (ton)	荷重 (ton)
14.0	34.0				
16.0	34.0				
18.0	34.0	34.0			
20.0	34.0	32.8			
22.0	34.0	30.4	26.8		
24.0	32.4	28.4	25.2		
26.0	30.1	26.6	23.8		
28.0	28.0	25.0	22.6	19.8	
30.0	25.8	23.6	21.5	19.1	
32.0	23.4	22.4	20.6	18.4	13.9
34.0	21.4	21.3	19.7	17.8	13.6
36.0	19.5	20.3	18.9	17.3	13.4
38.0	17.9	18.5	18.2	16.8	13.2
40.0	16.4	17.0	17.5	16.5	
42.0	15.1	15.6	16.1	16.2	
44.0	13.9	14.4	14.7	15.1	
46.0	12.8	13.2	13.5		
48.0	11.8	12.1	12.3		
50.0	10.9				
掛数	4	4	4	4	4
危険角度 (°)	10	20	30	45	60
フック種類	83t	83t	83t	83t	83t
フック質量 (t)	1.00	1.00	1.00	1.00	1.00

HA性能

31.8mブーム+4.4m+31mヘビーリフトジブ

オフセット	10°	20°	30°	45°	60°
作業半径 (m)	荷重 (ton)	荷重 (ton)	荷重 (ton)	荷重 (ton)	荷重 (ton)
16.0	20.0				
18.0	20.0				
20.0	20.0				
22.0	20.0	20.0			
24.0	20.0	20.0			
26.0	20.0	20.0	19.4		
28.0	20.0	20.0	18.9		
30.0	20.0	20.0	18.5	15.6	
32.0	20.0	19.9	18.1	15.3	
34.0	19.4	19.5	17.7	15.1	12.4
36.0	17.5	18.8	17.4	14.9	12.3
38.0	15.9	17.1	17.1	14.7	12.3
40.0	14.4	15.5	16.5	14.6	12.2
42.0	13.0	14.0	15.0	14.5	12.2
44.0	11.8	12.7	13.6	14.4	12.2
46.0	10.7	11.5	12.3	13.2	12.2
48.0	9.7	10.4	11.1	11.9	
50.0	8.7	9.4	10.0	10.6	
55.0	6.6	7.1	7.5		
60.0	4.9	5.2			
掛数	2	2	2	2	2
危険角度 (°)	10	20	30	45	60
フック種類	24t	24t	24t	24t	24t
フック質量 (t)	0.88	0.88	0.88	0.88	0.88

HA性能

40.9mブーム+4.4m+31mヘビーリフトジブ

オフセット	10°	20°	30°	45°	60°
作業半径 (m)	荷重 (ton)	荷重 (ton)	荷重 (ton)	荷重 (ton)	荷重 (ton)
18.0	14.0				
20.0	14.0				
22.0	14.0				
24.0	14.0	14.0			
26.0	14.0	14.0			
28.0	14.0	14.0	14.0		
30.0	14.0	14.0	14.0		
32.0	14.0	14.0	14.0		
34.0	14.0	14.0	14.0	14.0	
36.0	14.0	14.0	14.0	14.0	
38.0	14.0	14.0	14.0	14.0	14.0
40.0	13.7	14.0	14.0	14.0	14.0
42.0	12.4	13.5	14.0	14.0	14.0
44.0	11.1	12.2	13.2	14.0	14.0
46.0	10.0	11.0	11.9	13.0	13.6
48.0	9.0	9.9	10.7	11.7	12.3
50.0	8.0	8.9	9.6	10.5	10.9
55.0	5.9	6.6	7.2	7.8	
60.0	4.2	4.7	5.2	5.5	
65.0	2.8	3.1	3.4		
掛数	2	2	2	2	2
危険角度 (°)	25	26	30	45	60
フック種類	24t	24t	24t	24t	24t
フック質量 (t)	0.88	0.88	0.88	0.88	0.88

HA性能

50.0mブーム+4.4m+31mヘビーリフトジブ

オフセット	10°	20°	30°	45°	60°
作業半径 (m)	荷重 (ton)	荷重 (ton)	荷重 (ton)	荷重 (ton)	荷重 (ton)
20.0	9.0				
22.0	9.0				
24.0	9.0				
26.0	9.0	9.0			
28.0	9.0	9.0			
30.0	9.0	9.0	7.8		
32.0	9.0	8.8	7.7		
34.0	9.0	8.6	7.5		
36.0	9.0	8.4	7.4	6.0	
38.0	9.0	8.2	7.3	5.9	4.7
40.0	9.0	8.1	7.2	5.9	4.6
42.0	8.9	8.0	7.1	5.8	4.6
44.0	8.7	7.9	7.0	5.8	4.6
46.0	8.6	7.8	7.0	5.8	4.6
48.0	8.3	7.7	6.9	5.8	4.6
50.0	7.4	7.6	6.9	5.8	4.6
55.0	5.4	6.2	6.9	5.8	
60.0	3.6	4.3	4.9	5.5	
65.0		2.7	3.1	3.5	
掛数	2	2	2	2	2
危険角度 (°)	40	41	41	45	60
フック種類	24t	24t	24t	24t	24t
フック質量 (t)	0.88	0.88	0.88	0.88	0.88

HA性能

45.5mブーム+4.4m+31mヘビーリフトジブ

オフセット	10°	20°	30°	45°	60°
作業半径 (m)	荷重 (ton)	荷重 (ton)	荷重 (ton)	荷重 (ton)	荷重 (ton)
20.0	12.0				
22.0	12.0				
24.0	12.0	12.0			
26.0	12.0	12.0			
28.0	12.0	12.0			
30.0	12.0	12.0	12.0		
32.0	12.0	12.0	12.0		
34.0	12.0	12.0	12.0	11.1	
36.0	12.0	12.0	12.0	11.0	
38.0	12.0	12.0	12.0	10.9	8.9
40.0	12.0	12.0	12.0	10.8	8.9
42.0	12.0	12.0	12.0	10.7	8.8
44.0	10.8	11.9	12.0	10.6	8.8
46.0	9.7	10.7	11.7	10.6	8.8
48.0	8.7	9.6	10.5	10.5	8.8
50.0	7.7	8.6	9.4	10.4	8.8
55.0	5.6	6.4	7.0	7.8	
60.0	3.9	4.5	5.0	5.5	
65.0		2.9	3.3		
掛数	2	2	2	2	2
危険角度 (°)	34	35	35	45	60
フック種類	24t	24t	24t	24t	24t
フック質量 (t)	0.88	0.88	0.88	0.88	0.88

HA性能

13.6mブーム+4.4m+40mヘビーリフトジブ

オフセット	10°	20°	30°	45°	60°
作業半径 (m)	荷重 (ton)	荷重 (ton)	荷重 (ton)	荷重 (ton)	荷重 (ton)
16.0	12.0				
18.0	12.0				
20.0	12.0				
22.0	12.0	12.0			
24.0	12.0	12.0			
26.0	12.0	12.0			
28.0	12.0	12.0	12.0		
30.0	12.0	12.0	12.0		
32.0	12.0	12.0	12.0		
34.0	12.0	12.0	12.0		
36.0	12.0	12.0	12.0	11.8	
38.0	12.0	12.0	12.0	11.2	
40.0	12.0	12.0	11.9	10.7	9.4
42.0	12.0	12.0	11.3	10.2	9.2
44.0	12.0	11.5	10.7	9.8	9.0
46.0	11.6	10.9	10.3	9.5	8.9
48.0	10.9	10.3	9.8	9.2	
50.0	10.3	9.9	9.5	9.0	
55.0	9.2				
掛数	1	1	1	1	1
危険角度 (°)	10	20	30	45	60
フック種類	12t	12t	12t	12t	12t
フック質量 (t)	0.53	0.53	0.53	0.53	0.53

HA性能

22.7mブーム+4.4m+40mヘビーリフトジブ

オフセット	10°	20°	30°	45°	60°
作業半径 (m)	荷重 (ton)	荷重 (ton)	荷重 (ton)	荷重 (ton)	荷重 (ton)
18.0	12.0				
20.0	12.0				
22.0	12.0				
24.0	12.0	12.0			
26.0	12.0	12.0			
28.0	12.0	12.0			
30.0	12.0	12.0	12.0		
32.0	12.0	12.0	12.0		
34.0	12.0	12.0	12.0		
36.0	12.0	12.0	12.0	12.0	
38.0	12.0	12.0	12.0	11.7	
40.0	12.0	12.0	12.0	11.3	
42.0	12.0	12.0	12.0	10.8	9.7
44.0	12.0	12.0	11.9	10.5	9.5
46.0	12.0	12.0	11.4	10.1	9.3
48.0	11.9	11.9	10.9	9.8	9.1
50.0	11.0	11.4	10.5	9.5	9.0
55.0	8.8	9.4	9.6	9.1	
60.0	7.0	7.4	7.7		
掛数	1	1	1	1	1
危険角度 (°)	10	20	30	45	60
フック種類	12t	12t	12t	12t	12t
フック質量 (t)	0.53	0.53	0.53	0.53	0.53

HA性能

18.15mブーム+4.4m+40mヘビーリフトジブ

オフセット	10°	20°	30°	45°	60°
作業半径 (m)	荷重 (ton)	荷重 (ton)	荷重 (ton)	荷重 (ton)	荷重 (ton)
18.0	12.0				
20.0	12.0				
22.0	12.0				
24.0	12.0	12.0			
26.0	12.0	12.0			
28.0	12.0	12.0			
30.0	12.0	12.0	12.0		
32.0	12.0	12.0	12.0		
34.0	12.0	12.0	12.0		
36.0	12.0	12.0	12.0	12.0	
38.0	12.0	12.0	12.0	11.5	
40.0	12.0	12.0	12.0	11.0	9.9
42.0	12.0	12.0	11.9	10.6	9.6
44.0	12.0	12.0	11.4	10.2	9.3
46.0	12.0	11.7	10.9	9.8	9.2
48.0	12.0	11.2	10.4	9.5	9.0
50.0	11.4	10.6	10.0	9.3	
55.0	10.0	9.6	9.2		
60.0	7.9				
掛数	1	1	1	1	1
危険角度 (°)	10	20	30	45	60
フック種類	12t	12t	12t	12t	12t
フック質量 (t)	0.53	0.53	0.53	0.53	0.53

HA性能

31.8mブーム+4.4m+40mヘビーリフトジブ

オフセット	10°	20°	30°	45°	60°
作業半径 (m)	荷重 (ton)	荷重 (ton)	荷重 (ton)	荷重 (ton)	荷重 (ton)
20.0	12.0				
22.0	12.0				
24.0	12.0				
26.0	12.0	12.0			
28.0	12.0	12.0			
30.0	12.0	12.0			
32.0	12.0	12.0	12.0		
34.0	12.0	12.0	12.0		
36.0	12.0	12.0	12.0		
38.0	12.0	12.0	12.0	12.0	
40.0	12.0	12.0	12.0	11.7	
42.0	12.0	12.0	12.0	11.3	
44.0	12.0	12.0	12.0	10.9	9.5
46.0	12.0	12.0	12.0	10.6	9.4
48.0	11.0	12.0	11.9	10.3	9.3
50.0	10.1	11.0	11.5	10.0	9.2
55.0	8.0	8.8	9.5	9.5	9.0
60.0	6.2	6.8	7.4	8.0	
65.0	4.7	5.1	5.5		
70.0	3.3	3.6			
掛数	1	1	1	1	1
危険角度 (°)	10	20	30	45	60
フック種類	12t	12t	12t	12t	12t
フック質量 (t)	0.53	0.53	0.53	0.53	0.53

HA性能

40.9mブーム+4.4m+40mヘビーリフトジブ

オフセット	10°	20°	30°	45°	60°
作業半径 (m)	荷重 (ton)	荷重 (ton)	荷重 (ton)	荷重 (ton)	荷重 (ton)
22.0	11.0				
24.0	11.0				
26.0	11.0				
28.0	11.0	11.0			
30.0	11.0	11.0			
32.0	11.0	11.0			
34.0	11.0	11.0	11.0		
36.0	11.0	11.0	11.0		
38.0	11.0	11.0	11.0		
40.0	11.0	11.0	11.0		
42.0	11.0	11.0	11.0	11.0	
44.0	11.0	11.0	11.0	11.0	
46.0	11.0	11.0	11.0	11.0	9.6
48.0	10.3	11.0	11.0	10.7	9.5
50.0	9.3	10.5	11.0	10.4	9.3
55.0	7.2	8.2	9.1	9.8	9.1
60.0	5.5	6.3	7.0	7.9	
65.0	4.0	4.6	5.2	5.8	
70.0	2.7	3.2	3.6		
75.0	1.5	1.9	2.1		
掛数	1	1	1	1	1
危険角度 (°)	24	25	30	45	60
フック種類	12t	12t	12t	12t	12t
フック質量 (t)	0.53	0.53	0.53	0.53	0.53

HA性能

50.0mブーム+4.4m+40mヘビーリフトジブ

オフセット	10°	20°	30°	45°	60°
作業半径 (m)	荷重 (ton)	荷重 (ton)	荷重 (ton)	荷重 (ton)	荷重 (ton)
24.0	7.0				
26.0	7.0				
28.0	7.0				
30.0	7.0	7.0			
32.0	7.0	7.0			
34.0	7.0	7.0			
36.0	7.0	6.8	5.9		
38.0	7.0	6.7	5.8		
40.0	7.0	6.5	5.6		
42.0	7.0	6.4	5.5		
44.0	7.0	6.2	5.4	4.3	
46.0	6.9	6.1	5.3	4.2	
48.0	6.7	6.0	5.2	4.2	3.1
50.0	6.6	5.9	5.2	4.1	3.1
55.0	6.3	5.7	5.0	4.1	3.1
60.0	4.9	5.5	5.0	4.1	3.1
65.0	3.4	4.1	4.9	4.1	
70.0	2.1	2.7	3.3	3.9	
75.0		1.5	1.9	2.3	
掛数	1	1	1	1	1
危険角度 (°)	40	40	40	45	60
フック種類	12t	12t	12t	12t	12t
フック質量 (t)	0.53	0.53	0.53	0.53	0.53

HA性能

45.5mブーム+4.4m+40mヘビーリフトジブ

オフセット	10°	20°	30°	45°	60°
作業半径 (m)	荷重 (ton)	荷重 (ton)	荷重 (ton)	荷重 (ton)	荷重 (ton)
24.0	10.0				
26.0	10.0				
28.0	10.0				
30.0	10.0	10.0			
32.0	10.0	10.0			
34.0	10.0	10.0			
36.0	10.0	10.0	10.0		
38.0	10.0	10.0	10.0		
40.0	10.0	10.0	10.0		
42.0	10.0	10.0	10.0	8.5	
44.0	10.0	10.0	10.0	8.3	
46.0	10.0	10.0	9.9	8.2	6.6
48.0	10.0	10.0	9.8	8.1	6.5
50.0	9.0	10.0	9.6	8.1	6.5
55.0	6.9	7.9	8.9	7.9	6.5
60.0	5.1	6.0	6.8	7.8	6.5
65.0	3.6	4.4	5.0	5.7	
70.0	2.4	2.9	3.5	3.9	
75.0		1.7	2.0		
掛数	1	1	1	1	1
危険角度 (°)	33	34	34	45	60
フック種類	12t	12t	12t	12t	12t
フック質量 (t)	0.53	0.53	0.53	0.53	0.53

HA性能

13.6mブーム+4.4m+47mヘビーリフトジブ

オフセット	10°	20°	30°	45°	60°
作業半径 (m)	荷重 (ton)	荷重 (ton)	荷重 (ton)	荷重 (ton)	荷重 (ton)
18.0	12.0				
20.0	12.0				
22.0	12.0				
24.0	12.0				
26.0	12.0	12.0			
28.0	12.0	12.0			
30.0	12.0	12.0			
32.0	12.0	12.0	12.0		
34.0	12.0	12.0	12.0		
36.0	12.0	12.0	11.7		
38.0	12.0	12.0	10.9		
40.0	12.0	11.2	10.3		
42.0	11.5	10.5	9.7	8.6	
44.0	10.8	9.9	9.2	8.2	
46.0	10.1	9.4	8.7	7.8	7.1
48.0	9.5	8.8	8.2	7.5	6.9
50.0	8.9	8.4	7.9	7.2	6.7
55.0	7.8	7.4	7.1	6.6	
60.0	6.9	6.7	6.5		
掛数	1	1	1	1	1
危険角度 (°)	10	20	30	45	60
フック種類	12t	12t	12t	12t	12t
フック質量 (t)	0.53	0.53	0.53	0.53	0.53

HA性能

22.7mブーム+4.4m+47mヘビーリフトジブ

オフセット	10°	20°	30°	45°	60°
作業半径 (m)	荷重 (ton)	荷重 (ton)	荷重 (ton)	荷重 (ton)	荷重 (ton)
20.0	12.0				
22.0	12.0				
24.0	12.0				
26.0	12.0				
28.0	12.0	12.0			
30.0	12.0	12.0			
32.0	12.0	12.0			
34.0	12.0	12.0	12.0		
36.0	12.0	12.0	12.0		
38.0	12.0	12.0	11.7		
40.0	12.0	12.0	11.1		
42.0	12.0	11.9	10.5	8.9	
44.0	12.0	11.2	10.0	8.6	
46.0	11.9	10.6	9.5	8.2	
48.0	11.2	10.1	9.1	7.9	7.1
50.0	10.6	9.6	8.7	7.6	6.9
55.0	9.3	8.5	7.8	7.0	6.5
60.0	7.6	7.6	7.2	6.6	
65.0	6.1	6.5	6.7		
70.0	4.8	4.9			
掛数	1	1	1	1	1
危険角度 (°)	10	20	30	45	60
フック種類	12t	12t	12t	12t	12t
フック質量 (t)	0.53	0.53	0.53	0.53	0.53

HA性能

18.15mブーム+4.4m+47mヘビーリフトジブ

オフセット	10°	20°	30°	45°	60°
作業半径 (m)	荷重 (ton)	荷重 (ton)	荷重 (ton)	荷重 (ton)	荷重 (ton)
20.0	12.0				
22.0	12.0				
24.0	12.0				
26.0	12.0	12.0			
28.0	12.0	12.0			
30.0	12.0	12.0			
32.0	12.0	12.0			
34.0	12.0	12.0	12.0		
36.0	12.0	12.0	12.0		
38.0	12.0	12.0	11.3		
40.0	12.0	12.0	10.7		
42.0	12.0	11.2	10.1	8.8	
44.0	11.7	10.6	9.6	8.4	
46.0	11.0	10.0	9.1	8.0	
48.0	10.4	9.5	8.7	7.7	7.0
50.0	9.8	9.0	8.3	7.4	6.8
55.0	8.5	8.0	7.4	6.8	6.5
60.0	7.5	7.1	6.8	6.5	
65.0	6.8	6.6			
掛数	1	1	1	1	1
危険角度 (°)	10	20	30	45	60
フック種類	12t	12t	12t	12t	12t
フック質量 (t)	0.53	0.53	0.53	0.53	0.53

HA性能

31.8mブーム+4.4m+47mヘビーリフトジブ

オフセット	10°	20°	30°	45°	60°
作業半径 (m)	荷重 (ton)	荷重 (ton)	荷重 (ton)	荷重 (ton)	荷重 (ton)
22.0	12.0				
24.0	12.0				
26.0	12.0				
28.0	12.0				
30.0	12.0	12.0			
32.0	12.0	12.0			
34.0	12.0	12.0			
36.0	12.0	12.0	12.0		
38.0	12.0	12.0	12.0		
40.0	12.0	12.0	11.8		
42.0	12.0	12.0	11.2		
44.0	12.0	12.0	10.7	8.8	
46.0	12.0	11.8	10.2	8.5	
48.0	11.6	11.2	9.8	8.2	
50.0	10.6	10.6	9.4	8.0	7.0
55.0	8.5	9.5	8.5	7.4	6.7
60.0	6.7	7.5	7.8	6.9	6.5
65.0	5.2	5.9	6.5	6.6	
70.0	3.9	4.4	4.9	5.3	
75.0	2.7	3.1	3.3		
80.0	1.7				
掛数	1	1	1	1	1
危険角度 (°)	12	20	30	45	60
フック種類	12t	12t	12t	12t	12t
フック質量 (t)	0.53	0.53	0.53	0.53	0.53

HA性能

40.9mブーム+4.4m+47mヘビーリフトジブ

オフセット	10°	20°	30°	45°	60°
作業半径 (m)	荷重 (ton)	荷重 (ton)	荷重 (ton)	荷重 (ton)	荷重 (ton)
26.0	8.0				
28.0	8.0				
30.0	8.0				
32.0	8.0	8.0			
34.0	8.0	8.0			
36.0	8.0	8.0			
38.0	8.0	8.0			
40.0	8.0	8.0	8.0		
42.0	8.0	8.0	8.0		
44.0	8.0	8.0	8.0		
46.0	8.0	8.0	8.0		
48.0	8.0	8.0	8.0	8.0	
50.0	8.0	8.0	8.0	8.0	
55.0	7.7	8.0	8.0	7.7	6.8
60.0	5.9	6.9	7.9	7.2	6.6
65.0	4.4	5.3	6.1	6.9	6.4
70.0	3.1	3.8	4.5	5.2	
75.0	2.0	2.6	3.1	3.5	
80.0		1.4	1.8		
掛数	1	1	1	1	1
危険角度 (°)	31	32	32	45	60
フック種類	12t	12t	12t	12t	12t
フック質量 (t)	0.53	0.53	0.53	0.53	0.53

HA性能

50.0mブーム+4.4m+47mヘビーリフトジブ

オフセット	10°	20°	30°	45°	60°
作業半径 (m)	荷重 (ton)	荷重 (ton)	荷重 (ton)	荷重 (ton)	荷重 (ton)
26.0	5.0				
28.0	5.0				
30.0	5.0				
32.0	5.0				
34.0	5.0	5.0			
36.0	5.0	5.0			
38.0	5.0	5.0			
40.0	5.0	5.0	4.5		
42.0	5.0	5.0	4.4		
44.0	5.0	5.0	4.3		
46.0	5.0	4.9	4.2		
48.0	5.0	4.8	4.1	3.1	
50.0	5.0	4.7	4.0	3.0	
55.0	5.0	4.4	3.8	2.9	2.0
60.0	4.8	4.2	3.7	2.8	2.0
65.0	3.8	4.1	3.6	2.8	2.0
70.0	2.5	3.3	3.6	2.8	2.0
75.0	1.4	2.1	2.7	2.8	
80.0			1.5	2.0	
掛数	1	1	1	1	1
危険角度 (°)	43	44	44	45	60
フック種類	12t	12t	12t	12t	12t
フック質量 (t)	0.53	0.53	0.53	0.53	0.53

HA性能

45.5mブーム+4.4m+47mヘビーリフトジブ

オフセット	10°	20°	30°	45°	60°
作業半径 (m)	荷重 (ton)	荷重 (ton)	荷重 (ton)	荷重 (ton)	荷重 (ton)
26.0	7.5				
28.0	7.5				
30.0	7.5				
32.0	7.5				
34.0	7.5	7.5			
36.0	7.5	7.5			
38.0	7.5	7.5			
40.0	7.5	7.5	7.5		
42.0	7.5	7.5	7.5		
44.0	7.5	7.5	7.5		
46.0	7.5	7.5	7.5		
48.0	7.5	7.5	7.5	6.7	
50.0	7.5	7.5	7.5	6.6	
55.0	7.4	7.5	7.5	6.4	4.9
60.0	5.6	6.7	7.5	6.2	4.9
65.0	4.1	5.0	5.9	6.1	4.9
70.0	2.8	3.6	4.3	5.1	
75.0	1.7	2.3	2.9	3.5	
80.0			1.6		
掛数	1	1	1	1	1
危険角度 (°)	38	39	39	45	60
フック種類	12t	12t	12t	12t	12t
フック質量 (t)	0.53	0.53	0.53	0.53	0.53

HA性能

13.6mブーム+4.4m+54mヘビーリフトジブ

オフセット	10°	20°	30°	45°	60°
作業半径 (m)	荷重 (ton)	荷重 (ton)	荷重 (ton)	荷重 (ton)	荷重 (ton)
22.0	9.3				
24.0	9.3				
26.0	9.3				
28.0	9.3				
30.0	9.1	8.9			
32.0	9.1	8.8			
34.0	9.0	8.8			
36.0	8.9	8.6			
38.0	8.7	8.2	7.7		
40.0	8.4	7.9	7.4		
42.0	8.0	7.6	7.2		
44.0	7.7	7.3	6.9		
46.0	7.4	7.0	6.7	6.2	
48.0	7.1	6.8	6.5	6.1	
50.0	6.9	6.6	6.3	5.9	
55.0	6.3	6.1	5.9	5.4	4.9
60.0	5.8	5.6	5.3	4.9	4.6
65.0	5.2	5.0	4.8		
掛数	1	1	1	1	1
危険角度 (°)	10	20	30	45	60
フック種類	12t	12t	12t	12t	12t
フック質量 (t)	0.53	0.53	0.53	0.53	0.53

HA性能

22.7mブーム+4.4m+54mヘビーリフトジブ

オフセット	10°	20°	30°	45°	60°
作業半径 (m)	荷重 (ton)	荷重 (ton)	荷重 (ton)	荷重 (ton)	荷重 (ton)
24.0	9.3				
26.0	9.3				
28.0	9.3				
30.0	9.1				
32.0	9.1	8.9			
34.0	9.1	8.8			
36.0	9.0	8.7			
38.0	8.9	8.6	7.9		
40.0	8.8	8.3	7.7		
42.0	8.7	8.0	7.4		
44.0	8.4	7.7	7.2		
46.0	8.1	7.5	7.0		
48.0	7.8	7.2	6.8	6.2	
50.0	7.5	7.0	6.6	6.0	
55.0	6.9	6.5	6.2	5.7	5.1
60.0	6.4	6.1	5.8	5.2	4.8
65.0	6.0	5.7	5.3	4.8	4.6
70.0	5.2	5.2	4.9	4.6	
75.0	4.1	4.4	4.6		
掛数	1	1	1	1	1
危険角度 (°)	10	20	30	45	60
フック種類	12t	12t	12t	12t	12t
フック質量 (t)	0.53	0.53	0.53	0.53	0.53

HA性能

18.15mブーム+4.4m+54mヘビーリフトジブ

オフセット	10°	20°	30°	45°	60°
作業半径 (m)	荷重 (ton)	荷重 (ton)	荷重 (ton)	荷重 (ton)	荷重 (ton)
22.0	9.3				
24.0	9.3				
26.0	9.3				
28.0	9.3				
30.0	9.1	9.0			
32.0	9.1	9.0			
34.0	9.1	8.9			
36.0	8.9	8.8			
38.0	8.8	8.4	7.8		
40.0	8.7	8.1	7.6		
42.0	8.4	7.8	7.3		
44.0	8.0	7.5	7.1		
46.0	7.7	7.3	6.8		
48.0	7.5	7.0	6.6	6.1	
50.0	7.2	6.8	6.4	6.0	
55.0	6.6	6.3	6.0	5.5	5.0
60.0	6.1	5.9	5.6	5.0	4.7
65.0	5.6	5.3	5.0	4.7	
70.0	5.0	4.8	4.7		
掛数	1	1	1	1	1
危険角度 (°)	10	20	30	45	60
フック種類	12t	12t	12t	12t	12t
フック質量 (t)	0.53	0.53	0.53	0.53	0.53

HA性能

31.8mブーム+4.4m+54mヘビーリフトジブ

オフセット	10°	20°	30°	45°	60°
作業半径 (m)	荷重 (ton)	荷重 (ton)	荷重 (ton)	荷重 (ton)	荷重 (ton)
26.0	9.0				
28.0	9.0				
30.0	9.0				
32.0	9.0	8.9			
34.0	9.0	8.8			
36.0	9.0	8.7			
38.0	8.9	8.7			
40.0	8.8	8.7	7.9		
42.0	8.7	8.4	7.6		
44.0	8.7	8.1	7.4		
46.0	8.7	7.9	7.2		
48.0	8.4	7.6	7.0		
50.0	8.1	7.4	6.8	6.1	
55.0	7.5	6.9	6.4	5.8	
60.0	6.9	6.5	6.1	5.5	4.9
65.0	5.6	6.1	5.8	5.1	4.7
70.0	4.3	5.0	5.3	4.8	
75.0	3.2	3.7	4.2	4.6	
80.0	2.1	2.6	2.9		
85.0		1.4			
掛数	1	1	1	1	1
危険角度 (°)	18	20	30	45	60
フック種類	12t	12t	12t	12t	12t
フック質量 (t)	0.53	0.53	0.53	0.53	0.53

HA性能

40.9mブーム+4.4m+54mヘビーリフトジブ

オフセット	10°	20°	30°	45°	60°
作業半径 (m)	荷重 (ton)	荷重 (ton)	荷重 (ton)	荷重 (ton)	荷重 (ton)
28.0	6.0				
30.0	6.0				
32.0	6.0				
34.0	6.0				
36.0	6.0	6.0			
38.0	6.0	6.0			
40.0	6.0	6.0			
42.0	6.0	6.0			
44.0	6.0	6.0	6.0		
46.0	6.0	6.0	6.0		
48.0	6.0	6.0	6.0		
50.0	6.0	6.0	6.0		
55.0	6.0	6.0	6.0	5.9	
60.0	6.0	6.0	6.0	5.7	4.9
65.0	4.8	5.8	6.0	5.3	4.7
70.0	3.5	4.4	5.2	5.0	4.6
75.0	2.4	3.1	3.8	4.6	
80.0	1.4	2.0	2.5	3.1	
85.0			1.4		
掛数	1	1	1	1	1
危険角度 (°)	37	38	38	45	60
フック種類	12t	12t	12t	12t	12t
フック質量 (t)	0.53	0.53	0.53	0.53	0.53

HA性能

50.0mブーム+4.4m+54mヘビーリフトジブ

オフセット	10°	20°	30°	45°	60°
作業半径 (m)	荷重 (ton)	荷重 (ton)	荷重 (ton)	荷重 (ton)	荷重 (ton)
30.0	4.1				
32.0	4.1				
34.0	4.1				
36.0	4.1				
38.0	4.1	4.1			
40.0	4.1	4.1			
42.0	4.1	4.1			
44.0	4.1	4.0			
46.0	4.1	3.9	3.2		
48.0	4.1	3.8	3.1		
50.0	4.1	3.7	3.0		
55.0	4.0	3.4	2.8	2.0	
60.0	3.7	3.2	2.7	1.9	
65.0	3.5	3.1	2.6	1.8	
70.0	2.8	2.9	2.5	1.8	
75.0	1.7	2.6	2.5	1.8	
80.0		1.5	2.2	1.8	
85.0				1.6	
掛数	1	1	1	1	1
危険角度 (°)	47	48	48	49	60
フック種類	12t	12t	12t	12t	12t
フック質量 (t)	0.53	0.53	0.53	0.53	0.53

HA性能

45.5mブーム+4.4m+54mヘビーリフトジブ

オフセット	10°	20°	30°	45°	60°
作業半径 (m)	荷重 (ton)	荷重 (ton)	荷重 (ton)	荷重 (ton)	荷重 (ton)
28.0	5.5				
30.0	5.5				
32.0	5.5				
34.0	5.5				
36.0	5.5	5.5			
38.0	5.5	5.5			
40.0	5.5	5.5			
42.0	5.5	5.5			
44.0	5.5	5.5	5.5		
46.0	5.5	5.5	5.5		
48.0	5.5	5.5	5.5		
50.0	5.5	5.5	5.5		
55.0	5.5	5.5	5.5	5.2	
60.0	5.5	5.5	5.5	5.0	3.7
65.0	4.5	5.5	5.5	4.8	3.6
70.0	3.2	4.1	5.0	4.7	3.6
75.0	2.0	2.8	3.6	4.5	3.6
80.0		1.7	2.3	3.1	
85.0				1.7	
掛数	1	1	1	1	1
危険角度 (°)	42	43	44	45	60
フック種類	12t	12t	12t	12t	12t
フック質量 (t)	0.53	0.53	0.53	0.53	0.53

HB性能

13.6mブーム+4.4m+13mヘビーリフトジブ

オフセット	10°	20°	30°	45°	60°
作業半径 (m)	荷重 (ton)	荷重 (ton)	荷重 (ton)	荷重 (ton)	荷重 (ton)
7.0	84.0				
8.0	84.0	84.0			
9.0	84.0	80.1			
10.0	80.8	76.0	65.8		
11.0	75.6	72.2	63.2		
12.0	70.0	68.9	60.7	50.9	
14.0	58.3	59.5	56.6	48.1	34.2
16.0	49.5	50.5	51.5	45.8	33.3
18.0	42.7	43.5	44.3	44.0	32.7
20.0	37.3	37.8	38.3	38.9	
22.0	32.3	32.7	33.0	33.4	
24.0	28.2	28.6	28.8		
26.0	25.0	25.2	25.3		
28.0	22.3				
掛数	8	8	8	8	8
危険角度 (°)	10	20	30	45	60
フック種類	150t	150t	150t	150t	150t
フック質量 (t)	1.86	1.86	1.86	1.86	1.86

HB性能

22.7mブーム+4.4m+13mヘビーリフトジブ

オフセット	10°	20°	30°	45°	60°
作業半径 (m)	荷重 (ton)	荷重 (ton)	荷重 (ton)	荷重 (ton)	荷重 (ton)
8.0	64.0				
9.0	64.0				
10.0	64.0	64.0			
11.0	64.0	64.0			
12.0	64.0	64.0	64.0		
14.0	54.6	56.5	58.3	51.8	
16.0	45.8	47.4	48.9	49.8	38.6
18.0	39.0	40.3	41.5	43.1	37.8
20.0	33.5	34.6	35.7	36.9	37.3
22.0	29.0	30.0	30.7	31.5	31.9
24.0	25.2	25.8	26.4	27.1	
26.0	21.9	22.5	22.9	23.4	
28.0	19.2	19.7	20.0	20.4	
30.0	16.9	17.3	17.6		
32.0	15.0	15.2	15.4		
34.0	13.2	13.4	13.5		
36.0	11.6	11.7			
掛数	6	6	6	6	6
危険角度 (°)	10	20	30	45	60
フック種類	83t	83t	83t	83t	83t
フック質量 (t)	1.00	1.00	1.00	1.00	1.00

HB性能

18.15mブーム+4.4m+13mヘビーリフトジブ

オフセット	10°	20°	30°	45°	60°
作業半径 (m)	荷重 (ton)	荷重 (ton)	荷重 (ton)	荷重 (ton)	荷重 (ton)
7.0	77.0				
8.0	77.0				
9.0	77.0	77.0			
10.0	77.0	77.0			
11.0	74.8	76.2	65.2		
12.0	67.8	69.8	63.0		
14.0	56.1	57.7	59.0	50.6	
16.0	47.3	48.6	49.9	48.4	36.2
18.0	40.5	41.6	42.6	43.9	35.5
20.0	35.0	36.0	36.8	37.7	35.1
22.0	30.4	31.1	31.6	32.2	
24.0	26.4	26.9	27.4	27.8	
26.0	23.2	23.6	23.9	24.2	
28.0	20.5	20.8	21.0		
30.0	18.2	18.4	18.5		
32.0	16.2	16.3			
掛数	8	8	8	8	8
危険角度 (°)	10	20	30	45	60
フック種類	150t	150t	150t	150t	150t
フック質量 (t)	1.86	1.86	1.86	1.86	1.86

HB性能

31.8mブーム+4.4m+13mヘビーリフトジブ

オフセット	10°	20°	30°	45°	60°
作業半径 (m)	荷重 (ton)	荷重 (ton)	荷重 (ton)	荷重 (ton)	荷重 (ton)
10.0	45.0				
11.0	44.8	40.3			
12.0	44.1	39.8			
14.0	42.8	38.8	35.3		
16.0	41.7	38.0	34.7	30.2	
18.0	38.8	37.2	34.1	29.8	25.8
20.0	33.3	34.6	33.7	29.6	25.8
22.0	28.8	29.9	30.7	29.5	25.8
24.0	25.0	25.8	26.5	27.3	25.8
26.0	21.7	22.4	23.0	23.7	24.0
28.0	19.0	19.6	20.1	20.7	20.9
30.0	16.7	17.2	17.7	18.1	
32.0	14.8	15.2	15.6	15.9	
34.0	13.0	13.4	13.7	14.0	
36.0	11.3	11.8	12.1		
38.0	9.9	10.3	10.5		
40.0	8.6	8.9	9.0		
42.0	7.4	7.6			
44.0	6.4	6.5			
46.0	5.4				
掛数	4	4	4	4	4
危険角度 (°)	10	20	30	45	60
フック種類	83t	83t	83t	83t	83t
フック質量 (t)	1.00	1.00	1.00	1.00	1.00

HB性能

13.6mブーム+4.4m+22mヘビーリフトジブ

オフセット	10°	20°	30°	45°	60°
作業半径 (m)	荷重 (ton)	荷重 (ton)	荷重 (ton)	荷重 (ton)	荷重 (ton)
10.0	54.0				
11.0	54.0				
12.0	54.0				
14.0	54.0	47.4			
16.0	49.9	43.1	38.0		
18.0	44.9	39.5	35.3		
20.0	39.2	36.6	33.0	28.1	
22.0	34.1	34.0	31.0	26.8	19.4
24.0	30.0	30.7	29.3	25.7	18.9
26.0	26.6	27.2	27.8	24.7	18.6
28.0	23.8	24.3	24.8	23.9	18.4
30.0	21.4	21.9	22.3	22.8	
32.0	19.4	19.8	20.1	20.4	
34.0	17.7	17.9	18.1		
36.0	16.2	16.3			
掛数	6	6	6	6	6
危険角度 (°)	10	20	30	45	60
フック種類	83t	83t	83t	83t	83t
フック質量 (t)	1.00	1.00	1.00	1.00	1.00

HB性能

22.7mブーム+4.4m+22mヘビーリフトジブ

オフセット	10°	20°	30°	45°	60°
作業半径 (m)	荷重 (ton)	荷重 (ton)	荷重 (ton)	荷重 (ton)	荷重 (ton)
11.0	45.0				
12.0	45.0				
14.0	45.0				
16.0	45.0	45.0			
18.0	41.9	44.0	39.5		
20.0	36.3	38.2	37.2		
22.0	31.5	32.9	34.2	30.0	
24.0	27.4	28.6	29.7	28.9	22.1
26.0	24.0	25.1	26.0	27.3	21.7
28.0	21.2	22.1	23.0	24.1	21.3
30.0	18.9	19.7	20.4	21.3	21.1
32.0	16.8	17.5	18.2	18.9	19.4
34.0	15.1	15.7	16.2	16.9	
36.0	13.6	14.1	14.5	15.0	
38.0	12.2	12.6	13.0	13.3	
40.0	11.0	11.3	11.6		
42.0	9.9	10.2	10.4		
44.0	8.8	9.0			
46.0	7.7				
掛数	4	4	4	4	4
危険角度 (°)	10	20	30	45	60
フック種類	83t	83t	83t	83t	83t
フック質量 (t)	1.00	1.00	1.00	1.00	1.00

HB性能

18.15mブーム+4.4m+22mヘビーリフトジブ

オフセット	10°	20°	30°	45°	60°
作業半径 (m)	荷重 (ton)	荷重 (ton)	荷重 (ton)	荷重 (ton)	荷重 (ton)
10.0	50.0				
11.0	50.0				
12.0	50.0				
14.0	50.0	49.4			
16.0	50.0	45.2			
18.0	43.1	41.7	36.4		
20.0	37.5	38.7	34.3		
22.0	32.5	33.7	32.3	28.2	
24.0	28.4	29.4	30.3	27.1	20.6
26.0	25.1	25.9	26.7	26.2	20.2
28.0	22.3	23.0	23.7	24.6	19.9
30.0	19.9	20.6	21.1	21.9	19.7
32.0	17.9	18.4	18.9	19.5	
34.0	16.2	16.6	17.0	17.4	
36.0	14.6	15.0	15.3		
38.0	13.3	13.6	13.8		
40.0	12.1	12.3			
42.0	11.0				
掛数	6	6	6	6	6
危険角度 (°)	10	20	30	45	60
フック種類	83t	83t	83t	83t	83t
フック質量 (t)	1.00	1.00	1.00	1.00	1.00

HB性能

31.8mブーム+4.4m+22mヘビーリフトジブ

オフセット	10°	20°	30°	45°	60°
作業半径 (m)	荷重 (ton)	荷重 (ton)	荷重 (ton)	荷重 (ton)	荷重 (ton)
14.0	30.0				
16.0	30.0	29.8			
18.0	30.0	28.9			
20.0	30.0	28.0	25.2		
22.0	30.0	27.3	24.6		
24.0	26.8	26.6	24.1	20.6	
26.0	23.4	24.6	23.7	20.3	17.0
28.0	20.6	21.7	22.6	20.1	16.9
30.0	18.3	19.2	20.1	19.9	16.9
32.0	16.3	17.1	17.9	18.8	16.9
34.0	14.5	15.2	15.9	16.8	16.9
36.0	13.0	13.6	14.2	14.9	15.3
38.0	11.6	12.2	12.7	13.3	
40.0	10.3	11.0	11.4	11.9	
42.0	9.1	9.7	10.2	10.6	
44.0	8.0	8.6	9.0	9.4	
46.0	7.0	7.5	7.8		
48.0	6.1	6.5	6.8		
50.0	5.3	5.6	5.8		
55.0	3.5				
掛数	4	4	4	4	4
危険角度 (°)	10	20	30	45	60
フック種類	83t	83t	83t	83t	83t
フック質量 (t)	1.00	1.00	1.00	1.00	1.00

HB性能

40.9mブーム+4.4m+22mヘビーリフトジブ

オフセット	10°	20°	30°	45°	60°
作業半径 (m)	荷重 (ton)	荷重 (ton)	荷重 (ton)	荷重 (ton)	荷重 (ton)
16.0	20.0				
18.0	20.0				
20.0	20.0	20.0			
22.0	20.0	20.0	20.0		
24.0	20.0	20.0	20.0		
26.0	20.0	20.0	20.0	20.0	
28.0	20.0	20.0	20.0	20.0	20.0
30.0	18.1	19.1	20.0	20.0	20.0
32.0	16.1	17.0	17.9	18.9	19.7
34.0	14.3	15.2	15.9	16.9	17.5
36.0	12.8	13.5	14.2	15.1	15.6
38.0	11.4	12.1	12.7	13.5	13.9
40.0	10.0	10.9	11.4	12.0	12.4
42.0	8.8	9.6	10.2	10.8	
44.0	7.7	8.4	9.0	9.6	
46.0	6.7	7.3	7.9	8.4	
48.0	5.8	6.4	6.8	7.3	
50.0	4.9	5.4	5.8	6.2	
55.0	3.1	3.4	3.7		
掛数	2	2	2	2	2
危険角度 (°)	28	28	30	45	60
フック種類	24t	24t	24t	24t	24t
フック質量 (t)	0.88	0.88	0.88	0.88	0.88

HB性能

50.0mブーム+4.4m+22mヘビーリフトジブ

オフセット	10°	20°	30°	45°	60°
作業半径 (m)	荷重 (ton)	荷重 (ton)	荷重 (ton)	荷重 (ton)	荷重 (ton)
18.0	11.0				
20.0	11.0				
22.0	11.0	11.0			
24.0	11.0	11.0	11.0		
26.0	11.0	11.0	11.0		
28.0	11.0	11.0	10.9	9.1	
30.0	11.0	11.0	10.8	9.1	7.5
32.0	11.0	11.0	10.6	9.0	7.5
34.0	11.0	11.0	10.5	9.0	7.5
36.0	11.0	11.0	10.4	8.9	7.5
38.0	10.9	11.0	10.4	8.9	7.5
40.0	9.6	10.5	10.3	8.9	7.5
42.0	8.4	9.2	10.0	8.9	7.5
44.0	7.3	8.1	8.8	8.9	7.5
46.0	6.3	7.0	7.6	8.4	
48.0	5.3	6.0	6.6	7.2	
50.0	4.5	5.1	5.6	6.2	
55.0		3.1	3.5	3.9	
掛数	2	2	2	2	2
危険角度 (°)	41	42	42	45	60
フック種類	24t	24t	24t	24t	24t
フック質量 (t)	0.88	0.88	0.88	0.88	0.88

HB性能

45.5mブーム+4.4m+22mヘビーリフトジブ

オフセット	10°	20°	30°	45°	60°
作業半径 (m)	荷重 (ton)	荷重 (ton)	荷重 (ton)	荷重 (ton)	荷重 (ton)
16.0	16.0				
18.0	16.0				
20.0	16.0	16.0			
22.0	16.0	16.0			
24.0	16.0	16.0	16.0		
26.0	16.0	16.0	16.0		
28.0	16.0	16.0	16.0	15.6	
30.0	16.0	16.0	16.0	15.4	13.0
32.0	15.9	16.0	16.0	15.3	13.0
34.0	14.1	15.0	15.8	15.2	12.9
36.0	12.6	13.4	14.1	15.0	12.9
38.0	11.1	12.0	12.6	13.4	12.9
40.0	9.8	10.7	11.3	12.0	12.4
42.0	8.6	9.4	10.1	10.7	11.0
44.0	7.5	8.2	8.9	9.6	
46.0	6.5	7.2	7.8	8.4	
48.0	5.6	6.2	6.7	7.3	
50.0	4.7	5.3	5.8	6.2	
55.0	2.9	3.3	3.6		
掛数	2	2	2	2	2
危険角度 (°)	36	36	36	45	60
フック種類	24t	24t	24t	24t	24t
フック質量 (t)	0.88	0.88	0.88	0.88	0.88

HB性能

13.6mブーム+4.4m+31mヘビーリフトジブ

オフセット	10°	20°	30°	45°	60°
作業半径 (m)	荷重 (ton)	荷重 (ton)	荷重 (ton)	荷重 (ton)	荷重 (ton)
14.0	35.0				
16.0	34.4				
18.0	34.4	33.8			
20.0	34.4	31.5			
22.0	32.8	29.1	26.1		
24.0	30.2	27.1	24.5		
26.0	27.7	25.3	23.1		
28.0	24.9	23.7	21.8	18.8	
30.0	22.5	22.4	20.7	18.0	
32.0	20.4	21.0	19.7	17.3	12.7
34.0	18.6	19.1	18.9	16.7	12.4
36.0	17.0	17.5	18.0	16.2	12.2
38.0	15.7	16.1	16.5	15.8	
40.0	14.4	14.8	15.1	15.5	
42.0	13.4	13.6	13.9		
44.0	12.4	12.6	12.7		
46.0	11.5				
掛数	4	4	4	4	4
危険角度 (°)	10	20	30	45	60
フック種類	83t	83t	83t	83t	83t
フック質量 (t)	1.00	1.00	1.00	1.00	1.00

HB性能

22.7mブーム+4.4m+31mヘビーリフトジブ

オフセット	10°	20°	30°	45°	60°
作業半径 (m)	荷重 (ton)	荷重 (ton)	荷重 (ton)	荷重 (ton)	荷重 (ton)
16.0	30.0				
18.0	30.0				
20.0	30.0	30.0			
22.0	30.0	30.0			
24.0	28.8	29.6	25.8		
26.0	25.3	26.8	24.5		
28.0	22.5	23.8	23.3		
30.0	20.1	21.2	22.2	19.4	
32.0	18.0	19.0	20.0	18.7	
34.0	16.2	17.1	18.0	18.2	14.5
36.0	14.7	15.5	16.3	17.4	14.2
38.0	13.3	14.0	14.7	15.7	14.1
40.0	12.1	12.7	13.3	14.2	13.9
42.0	11.0	11.5	12.1	12.8	
44.0	10.0	10.5	11.0	11.5	
46.0	9.1	9.5	9.9	10.4	
48.0	8.1	8.6	9.0		
50.0	7.3	7.7	8.0		
55.0	5.4				
掛数	4	4	4	4	4
危険角度 (°)	10	20	30	45	60
フック種類	83t	83t	83t	83t	83t
フック質量 (t)	1.00	1.00	1.00	1.00	1.00

HB性能

18.15mブーム+4.4m+31mヘビーリフトジブ

オフセット	10°	20°	30°	45°	60°
作業半径 (m)	荷重 (ton)	荷重 (ton)	荷重 (ton)	荷重 (ton)	荷重 (ton)
14.0	34.0				
16.0	34.0				
18.0	34.0	34.0			
20.0	34.0	32.8			
22.0	34.0	30.4	26.8		
24.0	29.9	28.4	25.2		
26.0	26.4	26.6	23.8		
28.0	23.6	24.6	22.6	19.8	
30.0	21.2	22.1	21.5	19.1	
32.0	19.1	19.9	20.6	18.4	13.9
34.0	17.3	18.1	18.8	17.8	13.6
36.0	15.8	16.4	17.1	17.3	13.4
38.0	14.4	15.0	15.5	16.3	13.2
40.0	13.2	13.7	14.1	14.8	
42.0	12.1	12.5	12.9	13.4	
44.0	11.1	11.4	11.8	12.1	
46.0	10.2	10.5	10.7		
48.0	9.4	9.6	9.7		
50.0	8.6				
掛数	4	4	4	4	4
危険角度 (°)	10	20	30	45	60
フック種類	83t	83t	83t	83t	83t
フック質量 (t)	1.00	1.00	1.00	1.00	1.00

HB性能

31.8mブーム+4.4m+31mヘビーリフトジブ

オフセット	10°	20°	30°	45°	60°
作業半径 (m)	荷重 (ton)	荷重 (ton)	荷重 (ton)	荷重 (ton)	荷重 (ton)
16.0	20.0				
18.0	20.0				
20.0	20.0				
22.0	20.0	20.0			
24.0	20.0	20.0			
26.0	20.0	20.0	19.4		
28.0	20.0	20.0	18.9		
30.0	19.7	20.0	18.5	15.6	
32.0	17.6	18.8	18.1	15.3	
34.0	15.8	16.9	17.7	15.1	12.4
36.0	14.2	15.2	16.1	14.9	12.3
38.0	12.9	13.7	14.6	14.7	12.3
40.0	11.6	12.4	13.2	14.2	12.2
42.0	10.5	11.3	11.9	12.8	12.2
44.0	9.5	10.2	10.8	11.6	12.0
46.0	8.4	9.2	9.8	10.4	10.8
48.0	7.5	8.2	8.8	9.4	
50.0	6.6	7.3	7.9	8.4	
55.0	4.7	5.2	5.6		
60.0	3.2	3.4			
掛数	2	2	2	2	2
危険角度 (°)	13	20	30	45	60
フック種類	24t	24t	24t	24t	24t
フック質量 (t)	0.88	0.88	0.88	0.88	0.88

HB性能

40.9mブーム+4.4m+31mヘビーリフトジブ

オフセット	10°	20°	30°	45°	60°
作業半径 (m)	荷重 (ton)	荷重 (ton)	荷重 (ton)	荷重 (ton)	荷重 (ton)
18.0	14.0				
20.0	14.0				
22.0	14.0				
24.0	14.0	14.0			
26.0	14.0	14.0			
28.0	14.0	14.0	14.0		
30.0	14.0	14.0	14.0		
32.0	14.0	14.0	14.0		
34.0	14.0	14.0	14.0	14.0	
36.0	13.7	14.0	14.0	14.0	
38.0	12.3	13.3	14.0	14.0	14.0
40.0	11.1	12.0	12.9	14.0	14.0
42.0	9.9	10.9	11.6	12.6	13.4
44.0	8.8	9.8	10.5	11.4	12.0
46.0	7.7	8.7	9.5	10.3	10.8
48.0	6.8	7.7	8.5	9.3	9.7
50.0	5.9	6.8	7.5	8.4	8.7
55.0	4.1	4.7	5.3	5.9	
60.0		3.0	3.4	3.8	
掛数	2	2	2	2	2
危険角度 (°)	36	37	37	45	60
フック種類	24t	24t	24t	24t	24t
フック質量 (t)	0.88	0.88	0.88	0.88	0.88

HB性能

50.0mブーム+4.4m+31mヘビーリフトジブ

オフセット	10°	20°	30°	45°	60°
作業半径 (m)	荷重 (ton)	荷重 (ton)	荷重 (ton)	荷重 (ton)	荷重 (ton)
20.0	9.0				
22.0	9.0				
24.0	9.0				
26.0	9.0	9.0			
28.0	9.0	9.0			
30.0	9.0	9.0	7.8		
32.0	9.0	8.8	7.7		
34.0	9.0	8.6	7.5		
36.0	9.0	8.4	7.4	6.0	
38.0	9.0	8.2	7.3	5.9	4.7
40.0	9.0	8.1	7.2	5.9	4.6
42.0	8.9	8.0	7.1	5.8	4.6
44.0	8.2	7.9	7.0	5.8	4.6
46.0	7.2	7.8	7.0	5.8	4.6
48.0	6.2	7.3	6.9	5.8	4.6
50.0	5.4	6.3	6.9	5.8	4.6
55.0	3.5	4.3	5.0	5.8	
60.0			3.1	3.7	
掛数	2	2	2	2	2
危険角度 (°)	47	47	48	48	60
フック種類	24t	24t	24t	24t	24t
フック質量 (t)	0.88	0.88	0.88	0.88	0.88

HB性能

45.5mブーム+4.4m+31mヘビーリフトジブ

オフセット	10°	20°	30°	45°	60°
作業半径 (m)	荷重 (ton)	荷重 (ton)	荷重 (ton)	荷重 (ton)	荷重 (ton)
20.0	12.0				
22.0	12.0				
24.0	12.0	12.0			
26.0	12.0	12.0			
28.0	12.0	12.0			
30.0	12.0	12.0	12.0		
32.0	12.0	12.0	12.0		
34.0	12.0	12.0	12.0	11.1	
36.0	12.0	12.0	12.0	11.0	
38.0	12.0	12.0	12.0	10.9	8.9
40.0	10.8	11.8	12.0	10.8	8.9
42.0	9.6	10.7	11.5	10.7	8.8
44.0	8.5	9.6	10.4	10.6	8.8
46.0	7.4	8.5	9.4	10.2	8.8
48.0	6.5	7.5	8.4	9.2	8.8
50.0	5.6	6.5	7.4	8.3	8.7
55.0	3.8	4.5	5.2	5.9	
60.0		2.8	3.3	3.8	
掛数	2	2	2	2	2
危険角度 (°)	42	43	43	45	60
フック種類	24t	24t	24t	24t	24t
フック質量 (t)	0.88	0.88	0.88	0.88	0.88

HB性能

13.6mブーム+4.4m+40mヘビーリフトジブ

オフセット	10°	20°	30°	45°	60°
作業半径 (m)	荷重 (ton)	荷重 (ton)	荷重 (ton)	荷重 (ton)	荷重 (ton)
16.0	12.0				
18.0	12.0				
20.0	12.0				
22.0	12.0	12.0			
24.0	12.0	12.0			
26.0	12.0	12.0			
28.0	12.0	12.0	12.0		
30.0	12.0	12.0	12.0		
32.0	12.0	12.0	12.0		
34.0	12.0	12.0	12.0		
36.0	12.0	12.0	12.0	11.8	
38.0	12.0	12.0	12.0	11.2	
40.0	12.0	12.0	11.9	10.7	9.4
42.0	12.0	12.0	11.3	10.2	9.2
44.0	12.0	11.5	10.7	9.8	9.0
46.0	11.6	10.9	10.3	9.5	8.9
48.0	10.9	10.3	9.8	9.2	
50.0	10.3	9.9	9.5	9.0	
55.0	9.1				
掛数	1	1	1	1	1
危険角度 (°)	10	20	30	45	60
フック種類	12t	12t	12t	12t	12t
フック質量 (t)	0.53	0.53	0.53	0.53	0.53

HB性能

22.7mブーム+4.4m+40mヘビーリフトジブ

オフセット	10°	20°	30°	45°	60°
作業半径 (m)	荷重 (ton)	荷重 (ton)	荷重 (ton)	荷重 (ton)	荷重 (ton)
18.0	12.0				
20.0	12.0				
22.0	12.0				
24.0	12.0	12.0			
26.0	12.0	12.0			
28.0	12.0	12.0			
30.0	12.0	12.0	12.0		
32.0	12.0	12.0	12.0		
34.0	12.0	12.0	12.0		
36.0	12.0	12.0	12.0	12.0	
38.0	12.0	12.0	12.0	11.7	
40.0	12.0	12.0	12.0	11.3	
42.0	12.0	12.0	12.0	10.8	9.7
44.0	11.2	12.0	11.9	10.5	9.5
46.0	10.3	11.0	11.4	10.1	9.3
48.0	9.5	10.1	10.7	9.8	9.1
50.0	8.7	9.3	9.8	9.5	9.0
55.0	6.9	7.5	7.9	8.3	
60.0	5.3	5.7	6.0		
掛数	1	1	1	1	1
危険角度 (°)	10	20	30	45	60
フック種類	12t	12t	12t	12t	12t
フック質量 (t)	0.53	0.53	0.53	0.53	0.53

HB性能

18.15mブーム+4.4m+40mヘビーリフトジブ

オフセット	10°	20°	30°	45°	60°
作業半径 (m)	荷重 (ton)	荷重 (ton)	荷重 (ton)	荷重 (ton)	荷重 (ton)
18.0	12.0				
20.0	12.0				
22.0	12.0				
24.0	12.0	12.0			
26.0	12.0	12.0			
28.0	12.0	12.0			
30.0	12.0	12.0	12.0		
32.0	12.0	12.0	12.0		
34.0	12.0	12.0	12.0		
36.0	12.0	12.0	12.0	12.0	
38.0	12.0	12.0	12.0	11.5	
40.0	12.0	12.0	12.0	11.0	9.9
42.0	12.0	12.0	11.9	10.6	9.6
44.0	12.0	12.0	11.4	10.2	9.3
46.0	11.3	11.7	10.9	9.8	9.2
48.0	10.4	10.9	10.4	9.5	9.0
50.0	9.7	10.1	10.0	9.3	
55.0	8.0	8.3	8.5		
60.0	6.6				
掛数	1	1	1	1	1
危険角度 (°)	10	20	30	45	60
フック種類	12t	12t	12t	12t	12t
フック質量 (t)	0.53	0.53	0.53	0.53	0.53

HB性能

31.8mブーム+4.4m+40mヘビーリフトジブ

オフセット	10°	20°	30°	45°	60°
作業半径 (m)	荷重 (ton)	荷重 (ton)	荷重 (ton)	荷重 (ton)	荷重 (ton)
20.0	12.0				
22.0	12.0				
24.0	12.0				
26.0	12.0	12.0			
28.0	12.0	12.0			
30.0	12.0	12.0			
32.0	12.0	12.0	12.0		
34.0	12.0	12.0	12.0		
36.0	12.0	12.0	12.0		
38.0	12.0	12.0	12.0	12.0	
40.0	12.0	12.0	12.0	11.7	
42.0	11.6	12.0	12.0	11.3	
44.0	10.6	11.5	12.0	10.9	9.5
46.0	9.7	10.5	11.3	10.6	9.4
48.0	8.8	9.6	10.3	10.3	9.3
50.0	8.0	8.8	9.5	10.0	9.2
55.0	6.1	6.9	7.5	8.2	8.5
60.0	4.5	5.1	5.7	6.3	
65.0	3.1	3.5	3.9		
70.0	1.9	2.1			
掛数	1	1	1	1	1
危険角度 (°)	11	20	30	45	60
フック種類	12t	12t	12t	12t	12t
フック質量 (t)	0.53	0.53	0.53	0.53	0.53

HB性能

40.9mブーム+4.4m+40mヘビーリフトジブ

オフセット	10°	20°	30°	45°	60°
作業半径 (m)	荷重 (ton)	荷重 (ton)	荷重 (ton)	荷重 (ton)	荷重 (ton)
22.0	11.0				
24.0	11.0				
26.0	11.0				
28.0	11.0	11.0			
30.0	11.0	11.0			
32.0	11.0	11.0			
34.0	11.0	11.0	11.0		
36.0	11.0	11.0	11.0		
38.0	11.0	11.0	11.0		
40.0	11.0	11.0	11.0		
42.0	11.0	11.0	11.0	11.0	
44.0	10.1	11.0	11.0	11.0	
46.0	9.1	10.1	11.0	11.0	9.6
48.0	8.1	9.2	10.0	10.7	9.5
50.0	7.3	8.4	9.1	10.2	9.3
55.0	5.3	6.3	7.2	8.0	8.6
60.0	3.7	4.5	5.3	6.1	
65.0	2.4	3.0	3.6	4.2	
70.0		1.7	2.1		
掛数	1	1	1	1	1
危険角度 (°)	35	36	36	45	60
フック種類	12t	12t	12t	12t	12t
フック質量 (t)	0.53	0.53	0.53	0.53	0.53

HB性能

50.0mブーム+4.4m+40mヘビーリフトジブ

オフセット	10°	20°	30°	45°	60°
作業半径 (m)	荷重 (ton)	荷重 (ton)	荷重 (ton)	荷重 (ton)	荷重 (ton)
24.0	7.0				
26.0	7.0				
28.0	7.0				
30.0	7.0	7.0			
32.0	7.0	7.0			
34.0	7.0	7.0			
36.0	7.0	6.8	5.9		
38.0	7.0	6.7	5.8		
40.0	7.0	6.5	5.6		
42.0	7.0	6.4	5.5		
44.0	7.0	6.2	5.4	4.3	
46.0	6.9	6.1	5.3	4.2	
48.0	6.7	6.0	5.2	4.2	3.1
50.0	6.6	5.9	5.2	4.1	3.1
55.0	4.7	5.7	5.0	4.1	3.1
60.0	3.1	4.1	4.9	4.1	3.1
65.0	1.8	2.5	3.3	4.1	
70.0			1.8	2.4	
掛数	1	1	1	1	1
危険角度 (°)	47	48	48	48	60
フック種類	12t	12t	12t	12t	12t
フック質量 (t)	0.53	0.53	0.53	0.53	0.53

HB性能

45.5mブーム+4.4m+40mヘビーリフトジブ

オフセット	10°	20°	30°	45°	60°
作業半径 (m)	荷重 (ton)	荷重 (ton)	荷重 (ton)	荷重 (ton)	荷重 (ton)
24.0	10.0				
26.0	10.0				
28.0	10.0				
30.0	10.0	10.0			
32.0	10.0	10.0			
34.0	10.0	10.0			
36.0	10.0	10.0	10.0		
38.0	10.0	10.0	10.0		
40.0	10.0	10.0	10.0		
42.0	10.0	10.0	10.0	8.5	
44.0	9.8	10.0	10.0	8.3	
46.0	8.8	9.9	9.9	8.2	6.6
48.0	7.8	9.0	9.8	8.1	6.5
50.0	6.9	8.1	9.0	8.1	6.5
55.0	5.0	6.0	7.0	7.9	6.5
60.0	3.4	4.3	5.1	6.0	6.5
65.0	2.1	2.8	3.4	4.2	
70.0		1.5	2.0	2.5	
掛数	1	1	1	1	1
危険角度 (°)	41	42	42	45	60
フック種類	12t	12t	12t	12t	12t
フック質量 (t)	0.53	0.53	0.53	0.53	0.53

HB性能

13.6mブーム+4.4m+47mヘビーリフトジブ

オフセット	10°	20°	30°	45°	60°
作業半径 (m)	荷重 (ton)	荷重 (ton)	荷重 (ton)	荷重 (ton)	荷重 (ton)
18.0	12.0				
20.0	12.0				
22.0	12.0				
24.0	12.0				
26.0	12.0	12.0			
28.0	12.0	12.0			
30.0	12.0	12.0			
32.0	12.0	12.0	12.0		
34.0	12.0	12.0	12.0		
36.0	12.0	12.0	11.7		
38.0	12.0	12.0	10.9		
40.0	12.0	11.2	10.3		
42.0	11.5	10.5	9.7	8.6	
44.0	10.8	9.9	9.2	8.2	
46.0	10.1	9.4	8.7	7.8	7.1
48.0	9.5	8.8	8.2	7.5	6.9
50.0	8.9	8.4	7.9	7.2	6.7
55.0	7.8	7.4	7.1	6.6	
60.0	6.9	6.7	6.5		
掛数	1	1	1	1	1
危険角度 (°)	10	20	30	45	60
フック種類	12t	12t	12t	12t	12t
フック質量 (t)	0.53	0.53	0.53	0.53	0.53

HB性能

22.7mブーム+4.4m+47mヘビーリフトジブ

オフセット	10°	20°	30°	45°	60°
作業半径 (m)	荷重 (ton)	荷重 (ton)	荷重 (ton)	荷重 (ton)	荷重 (ton)
20.0	12.0				
22.0	12.0				
24.0	12.0				
26.0	12.0				
28.0	12.0	12.0			
30.0	12.0	12.0			
32.0	12.0	12.0			
34.0	12.0	12.0	12.0		
36.0	12.0	12.0	12.0		
38.0	12.0	12.0	11.7		
40.0	12.0	12.0	11.1		
42.0	12.0	11.9	10.5	8.9	
44.0	11.7	11.2	10.0	8.6	
46.0	10.8	10.6	9.5	8.2	
48.0	9.9	10.1	9.1	7.9	7.1
50.0	9.2	9.6	8.7	7.6	6.9
55.0	7.5	8.1	7.8	7.0	6.5
60.0	5.9	6.5	7.0	6.6	
65.0	4.5	5.0	5.3		
70.0	3.3	3.5			
掛数	1	1	1	1	1
危険角度 (°)	10	20	30	45	60
フック種類	12t	12t	12t	12t	12t
フック質量 (t)	0.53	0.53	0.53	0.53	0.53

HB性能

18.15mブーム+4.4m+47mヘビーリフトジブ

オフセット	10°	20°	30°	45°	60°
作業半径 (m)	荷重 (ton)	荷重 (ton)	荷重 (ton)	荷重 (ton)	荷重 (ton)
20.0	12.0				
22.0	12.0				
24.0	12.0				
26.0	12.0	12.0			
28.0	12.0	12.0			
30.0	12.0	12.0			
32.0	12.0	12.0			
34.0	12.0	12.0	12.0		
36.0	12.0	12.0	12.0		
38.0	12.0	12.0	11.3		
40.0	12.0	12.0	10.7		
42.0	12.0	11.2	10.1	8.8	
44.0	11.7	10.6	9.6	8.4	
46.0	11.0	10.0	9.1	8.0	
48.0	10.4	9.5	8.7	7.7	7.0
50.0	9.8	9.0	8.3	7.4	6.8
55.0	8.4	8.0	7.4	6.8	6.5
60.0	7.0	7.1	6.8	6.5	
65.0	5.8	6.0			
掛数	1	1	1	1	1
危険角度 (°)	10	20	30	45	60
フック種類	12t	12t	12t	12t	12t
フック質量 (t)	0.53	0.53	0.53	0.53	0.53

HB性能

31.8mブーム+4.4m+47mヘビーリフトジブ

オフセット	10°	20°	30°	45°	60°
作業半径 (m)	荷重 (ton)	荷重 (ton)	荷重 (ton)	荷重 (ton)	荷重 (ton)
22.0	12.0				
24.0	12.0				
26.0	12.0				
28.0	12.0				
30.0	12.0	12.0			
32.0	12.0	12.0			
34.0	12.0	12.0			
36.0	12.0	12.0	12.0		
38.0	12.0	12.0	12.0		
40.0	12.0	12.0	11.8		
42.0	12.0	12.0	11.2		
44.0	11.0	12.0	10.7	8.8	
46.0	10.1	11.1	10.2	8.5	
48.0	9.3	10.2	9.8	8.2	
50.0	8.5	9.4	9.4	8.0	7.0
55.0	6.6	7.6	8.2	7.4	6.7
60.0	5.0	5.8	6.6	6.9	6.5
65.0	3.6	4.3	4.9	5.7	
70.0	2.4	2.9	3.4	3.8	
75.0	1.4	1.7	2.0		
掛数	1	1	1	1	1
危険角度 (°)	21	21	30	45	60
フック種類	12t	12t	12t	12t	12t
フック質量 (t)	0.53	0.53	0.53	0.53	0.53

HB性能

40.9mブーム+4.4m+47mヘビーリフトジブ

オフセット	10°	20°	30°	45°	60°
作業半径 (m)	荷重 (ton)	荷重 (ton)	荷重 (ton)	荷重 (ton)	荷重 (ton)
26.0	8.0				
28.0	8.0				
30.0	8.0				
32.0	8.0	8.0			
34.0	8.0	8.0			
36.0	8.0	8.0			
38.0	8.0	8.0			
40.0	8.0	8.0	8.0		
42.0	8.0	8.0	8.0		
44.0	8.0	8.0	8.0		
46.0	8.0	8.0	8.0		
48.0	8.0	8.0	8.0	8.0	
50.0	7.8	8.0	8.0	8.0	
55.0	5.8	7.0	7.9	7.7	6.8
60.0	4.2	5.2	6.1	7.2	6.6
65.0	2.8	3.7	4.5	5.5	6.0
70.0	1.7	2.4	3.0	3.7	
75.0			1.7	2.2	
掛数	1	1	1	1	1
危険角度 (°)	40	41	41	45	60
フック種類	12t	12t	12t	12t	12t
フック質量 (t)	0.53	0.53	0.53	0.53	0.53

HB性能

50.0mブーム+4.4m+47mヘビーリフトジブ

オフセット	10°	20°	30°	45°	60°
作業半径 (m)	荷重 (ton)	荷重 (ton)	荷重 (ton)	荷重 (ton)	荷重 (ton)
26.0	5.0				
28.0	5.0				
30.0	5.0				
32.0	5.0				
34.0	5.0	5.0			
36.0	5.0	5.0			
38.0	5.0	5.0			
40.0	5.0	5.0	4.5		
42.0	5.0	5.0	4.4		
44.0	5.0	5.0	4.3		
46.0	5.0	4.9	4.2		
48.0	5.0	4.8	4.1	3.1	
50.0	5.0	4.7	4.0	3.0	
55.0	5.0	4.4	3.8	2.9	2.0
60.0	3.6	4.2	3.7	2.8	2.0
65.0	2.2	3.2	3.6	2.8	2.0
70.0		1.9	2.6	2.8	2.0
75.0			1.3	2.1	
掛数	1	1	1	1	1
危険角度 (°)	49	50	50	51	60
フック種類	12t	12t	12t	12t	12t
フック質量 (t)	0.53	0.53	0.53	0.53	0.53

HB性能

45.5mブーム+4.4m+47mヘビーリフトジブ

オフセット	10°	20°	30°	45°	60°
作業半径 (m)	荷重 (ton)	荷重 (ton)	荷重 (ton)	荷重 (ton)	荷重 (ton)
26.0	7.5				
28.0	7.5				
30.0	7.5				
32.0	7.5				
34.0	7.5	7.5			
36.0	7.5	7.5			
38.0	7.5	7.5			
40.0	7.5	7.5	7.5		
42.0	7.5	7.5	7.5		
44.0	7.5	7.5	7.5		
46.0	7.5	7.5	7.5		
48.0	7.5	7.5	7.5	6.7	
50.0	7.4	7.5	7.5	6.6	
55.0	5.5	6.7	7.5	6.4	4.9
60.0	3.9	4.9	5.9	6.2	4.9
65.0	2.5	3.4	4.3	5.3	4.9
70.0	1.3	2.1	2.8	3.7	
75.0			1.5	2.1	
掛数	1	1	1	1	1
危険角度 (°)	45	46	47	47	60
フック種類	12t	12t	12t	12t	12t
フック質量 (t)	0.53	0.53	0.53	0.53	0.53

HB性能

13.6mブーム+4.4m+54mヘビーリフトジブ

オフセット	10°	20°	30°	45°	60°
作業半径 (m)	荷重 (ton)	荷重 (ton)	荷重 (ton)	荷重 (ton)	荷重 (ton)
22.0	9.3				
24.0	9.3				
26.0	9.3				
28.0	9.3				
30.0	9.1	8.9			
32.0	9.1	8.8			
34.0	9.0	8.8			
36.0	8.9	8.6			
38.0	8.7	8.2	7.7		
40.0	8.4	7.9	7.4		
42.0	8.0	7.6	7.2		
44.0	7.7	7.3	6.9		
46.0	7.4	7.0	6.7	6.2	
48.0	7.1	6.8	6.5	6.1	
50.0	6.9	6.6	6.3	5.9	
55.0	6.3	6.1	5.9	5.4	4.9
60.0	5.8	5.6	5.3	4.9	4.6
65.0	5.2	5.0	4.8		
掛数	1	1	1	1	1
危険角度 (°)	10	20	30	45	60
フック種類	12t	12t	12t	12t	12t
フック質量 (t)	0.53	0.53	0.53	0.53	0.53

HB性能

22.7mブーム+4.4m+54mヘビーリフトジブ

オフセット	10°	20°	30°	45°	60°
作業半径 (m)	荷重 (ton)	荷重 (ton)	荷重 (ton)	荷重 (ton)	荷重 (ton)
24.0	9.3				
26.0	9.3				
28.0	9.3				
30.0	9.1				
32.0	9.1	8.9			
34.0	9.1	8.8			
36.0	9.0	8.7			
38.0	8.9	8.6	7.9		
40.0	8.8	8.3	7.7		
42.0	8.7	8.0	7.4		
44.0	8.4	7.7	7.2		
46.0	8.1	7.5	7.0		
48.0	7.8	7.2	6.8	6.2	
50.0	7.5	7.0	6.6	6.0	
55.0	6.9	6.5	6.2	5.7	5.1
60.0	6.3	6.1	5.8	5.2	4.8
65.0	4.9	5.6	5.3	4.8	4.6
70.0	3.7	4.2	4.7	4.6	
75.0	2.7	3.0	3.2		
掛数	1	1	1	1	1
危険角度 (°)	10	20	30	45	60
フック種類	12t	12t	12t	12t	12t
フック質量 (t)	0.53	0.53	0.53	0.53	0.53

HB性能

18.15mブーム+4.4m+54mヘビーリフトジブ

オフセット	10°	20°	30°	45°	60°
作業半径 (m)	荷重 (ton)	荷重 (ton)	荷重 (ton)	荷重 (ton)	荷重 (ton)
22.0	9.3				
24.0	9.3				
26.0	9.3				
28.0	9.3				
30.0	9.1	9.0			
32.0	9.1	9.0			
34.0	9.1	8.9			
36.0	8.9	8.8			
38.0	8.8	8.4	7.8		
40.0	8.7	8.1	7.6		
42.0	8.4	7.8	7.3		
44.0	8.0	7.5	7.1		
46.0	7.7	7.3	6.8		
48.0	7.5	7.0	6.6	6.1	
50.0	7.2	6.8	6.4	6.0	
55.0	6.6	6.3	6.0	5.5	5.0
60.0	6.1	5.9	5.6	5.0	4.7
65.0	5.6	5.3	5.0	4.7	
70.0	4.9	4.8	4.7		
掛数	1	1	1	1	1
危険角度 (°)	10	20	30	45	60
フック種類	12t	12t	12t	12t	12t
フック質量 (t)	0.53	0.53	0.53	0.53	0.53

HB性能

31.8mブーム+4.4m+54mヘビーリフトジブ

オフセット	10°	20°	30°	45°	60°
作業半径 (m)	荷重 (ton)	荷重 (ton)	荷重 (ton)	荷重 (ton)	荷重 (ton)
26.0	9.0				
28.0	9.0				
30.0	9.0				
32.0	9.0	8.9			
34.0	9.0	8.8			
36.0	9.0	8.7			
38.0	8.9	8.7			
40.0	8.8	8.7	7.9		
42.0	8.7	8.4	7.6		
44.0	8.7	8.1	7.4		
46.0	8.7	7.9	7.2		
48.0	8.4	7.6	7.0		
50.0	8.1	7.4	6.8	6.1	
55.0	7.0	6.9	6.4	5.8	
60.0	5.4	6.4	6.1	5.5	4.9
65.0	4.0	4.8	5.7	5.1	4.7
70.0	2.8	3.5	4.2	4.8	
75.0	1.8	2.3	2.9	3.4	
80.0			1.6		
掛数	1	1	1	1	1
危険角度 (°)	31	31	31	45	60
フック種類	12t	12t	12t	12t	12t
フック質量 (t)	0.53	0.53	0.53	0.53	0.53

HB性能

40.9mブーム+4.4m+54mヘビーリフトジブ

オフセット	10°	20°	30°	45°	60°
作業半径 (m)	荷重 (ton)	荷重 (ton)	荷重 (ton)	荷重 (ton)	荷重 (ton)
28.0	6.0				
30.0	6.0				
32.0	6.0				
34.0	6.0				
36.0	6.0	6.0			
38.0	6.0	6.0			
40.0	6.0	6.0			
42.0	6.0	6.0			
44.0	6.0	6.0	6.0		
46.0	6.0	6.0	6.0		
48.0	6.0	6.0	6.0		
50.0	6.0	6.0	6.0		
55.0	6.0	6.0	6.0	5.9	
60.0	4.6	5.8	6.0	5.7	4.9
65.0	3.2	4.2	5.2	5.3	4.7
70.0	2.0	2.9	3.7	4.8	4.6
75.0		1.7	2.4	3.3	
80.0				1.8	
掛数	1	1	1	1	1
危険角度 (°)	44	45	46	46	60
フック種類	12t	12t	12t	12t	12t
フック質量 (t)	0.53	0.53	0.53	0.53	0.53

HB性能

50.0mブーム+4.4m+54mヘビーリフトジブ

オフセット	10°	20°	30°	45°	60°
作業半径 (m)	荷重 (ton)	荷重 (ton)	荷重 (ton)	荷重 (ton)	荷重 (ton)
30.0	4.1				
32.0	4.1				
34.0	4.1				
36.0	4.1				
38.0	4.1	4.1			
40.0	4.1	4.1			
42.0	4.1	4.1			
44.0	4.1	4.0			
46.0	4.1	3.9	3.2		
48.0	4.1	3.8	3.1		
50.0	4.1	3.7	3.0		
55.0	4.0	3.4	2.8	2.0	
60.0	3.7	3.2	2.7	1.9	
65.0	2.5	3.1	2.6	1.8	
70.0		2.4	2.5	1.8	
75.0			2.0	1.8	
80.0				1.7	
掛数	1	1	1	1	1
危険角度 (°)	52	53	54	54	60
フック種類	12t	12t	12t	12t	12t
フック質量 (t)	0.53	0.53	0.53	0.53	0.53

HB性能

45.5mブーム+4.4m+54mヘビーリフトジブ

オフセット	10°	20°	30°	45°	60°
作業半径 (m)	荷重 (ton)	荷重 (ton)	荷重 (ton)	荷重 (ton)	荷重 (ton)
28.0	5.5				
30.0	5.5				
32.0	5.5				
34.0	5.5				
36.0	5.5	5.5			
38.0	5.5	5.5			
40.0	5.5	5.5			
42.0	5.5	5.5			
44.0	5.5	5.5	5.5		
46.0	5.5	5.5	5.5		
48.0	5.5	5.5	5.5		
50.0	5.5	5.5	5.5		
55.0	5.5	5.5	5.5	5.2	
60.0	4.3	5.5	5.5	5.0	3.7
65.0	2.9	3.9	5.0	4.8	3.6
70.0	1.7	2.6	3.5	4.7	3.6
75.0		1.4	2.2	3.2	3.6
80.0				1.8	
掛数	1	1	1	1	1
危険角度 (°)	48	49	50	51	60
フック種類	12t	12t	12t	12t	12t
フック質量 (t)	0.53	0.53	0.53	0.53	0.53

HC性能

13.6mブーム+4.4m+13mヘビーリフトジブ

オフセット	10°	20°	30°	45°	60°
作業半径 (m)	荷重 (ton)	荷重 (ton)	荷重 (ton)	荷重 (ton)	荷重 (ton)
7.0	84.0				
8.0	84.0	84.0			
9.0	84.0	80.1			
10.0	76.8	76.0	65.8		
11.0	68.8	70.5	63.2		
12.0	62.0	63.6	60.7	50.9	
14.0	51.5	52.7	53.9	48.1	34.2
16.0	42.5	43.4	44.3	45.4	33.3
18.0	35.3	36.0	36.7	37.5	32.7
20.0	29.9	30.4	30.9	31.5	
22.0	25.7	26.1	26.5	26.8	
24.0	22.3	22.6	22.9		
26.0	19.6	19.8	19.9		
28.0	17.3				
掛数	8	8	8	8	8
危険角度 (°)	10	20	30	45	60
フック種類	150t	150t	150t	150t	150t
フック質量 (t)	1.86	1.86	1.86	1.86	1.86

HC性能

22.7mブーム+4.4m+13mヘビーリフトジブ

オフセット	10°	20°	30°	45°	60°
作業半径 (m)	荷重 (ton)	荷重 (ton)	荷重 (ton)	荷重 (ton)	荷重 (ton)
8.0	64.0				
9.0	64.0				
10.0	64.0	64.0			
11.0	64.0	64.0			
12.0	58.4	60.7	62.8		
14.0	47.8	49.7	51.4	51.8	
16.0	39.2	40.6	41.9	43.6	38.6
18.0	32.1	33.2	34.3	35.6	36.5
20.0	26.7	27.7	28.6	29.6	30.3
22.0	22.6	23.4	24.1	24.9	25.4
24.0	19.2	19.9	20.5	21.1	
26.0	16.5	17.1	17.6	18.0	
28.0	14.3	14.7	15.1	15.4	
30.0	12.4	12.7	13.0		
32.0	10.7	11.0	11.2		
34.0	9.3	9.5	9.6		
36.0	8.1	8.2			
掛数	6	6	6	6	6
危険角度 (°)	10	20	30	45	60
フック種類	83t	83t	83t	83t	83t
フック質量 (t)	1.00	1.00	1.00	1.00	1.00

HC性能

18.15mブーム+4.4m+13mヘビーリフトジブ

オフセット	10°	20°	30°	45°	60°
作業半径 (m)	荷重 (ton)	荷重 (ton)	荷重 (ton)	荷重 (ton)	荷重 (ton)
7.0	77.0				
8.0	77.0				
9.0	77.0	77.0			
10.0	74.7	77.0			
11.0	66.6	68.8	65.2		
12.0	59.9	61.8	63.0		
14.0	49.3	50.9	52.4	50.6	
16.0	40.6	41.7	42.9	44.3	36.2
18.0	33.4	34.3	35.2	36.3	35.5
20.0	28.0	28.8	29.5	30.3	30.8
22.0	23.8	24.5	25.0	25.7	
24.0	20.5	21.0	21.5	21.9	
26.0	17.8	18.2	18.5	18.8	
28.0	15.5	15.8	16.0		
30.0	13.6	13.8	13.9		
32.0	12.0				
掛数	8	8	8	8	8
危険角度 (°)	10	20	30	45	60
フック種類	150t	150t	150t	150t	150t
フック質量 (t)	1.86	1.86	1.86	1.86	1.86

HC性能

31.8mブーム+4.4m+13mヘビーリフトジブ

オフセット	10°	20°	30°	45°	60°
作業半径 (m)	荷重 (ton)	荷重 (ton)	荷重 (ton)	荷重 (ton)	荷重 (ton)
10.0	45.0				
11.0	44.8	40.3			
12.0	44.1	39.8			
14.0	42.8	38.8	35.3		
16.0	39.1	38.0	34.7	30.2	
18.0	31.9	33.2	34.1	29.8	25.8
20.0	26.6	27.6	28.6	29.6	25.8
22.0	22.4	23.3	24.1	25.1	25.7
24.0	19.1	19.9	20.6	21.4	21.8
26.0	16.4	17.0	17.6	18.3	18.6
28.0	14.1	14.7	15.2	15.7	16.0
30.0	12.2	12.7	13.1	13.6	
32.0	10.5	11.0	11.3	11.7	
34.0	9.1	9.5	9.8	10.0	
36.0	7.9	8.2	8.4		
38.0	6.8	7.0	7.2		
40.0	5.7	6.0	6.1		
42.0	4.5	4.7			
44.0	3.5	3.6			
掛数	4	4	4	4	4
危険角度 (°)	10	20	30	45	60
フック種類	83t	83t	83t	83t	83t
フック質量 (t)	1.00	1.00	1.00	1.00	1.00

HC性能

13.6mブーム+4.4m+22mヘビーリフトジブ

オフセット	10°	20°	30°	45°	60°
作業半径 (m)	荷重 (ton)	荷重 (ton)	荷重 (ton)	荷重 (ton)	荷重 (ton)
10.0	54.0				
11.0	54.0				
12.0	54.0				
14.0	53.9	47.4			
16.0	44.8	43.1	38.0		
18.0	37.4	38.6	35.3		
20.0	31.8	32.8	33.0	28.1	
22.0	27.5	28.4	29.2	26.8	19.4
24.0	24.0	24.8	25.5	25.7	18.9
26.0	21.2	21.8	22.4	23.3	18.6
28.0	18.9	19.4	19.9	20.5	18.4
30.0	16.9	17.3	17.7	18.2	
32.0	15.2	15.5	15.8	16.1	
34.0	13.7	14.0	14.2		
36.0	12.5	12.6			
掛数	6	6	6	6	6
危険角度 (°)	10	20	30	45	60
フック種類	83t	83t	83t	83t	83t
フック質量 (t)	1.00	1.00	1.00	1.00	1.00

HC性能

22.7mブーム+4.4m+22mヘビーリフトジブ

オフセット	10°	20°	30°	45°	60°
作業半径 (m)	荷重 (ton)	荷重 (ton)	荷重 (ton)	荷重 (ton)	荷重 (ton)
11.0	45.0				
12.0	45.0				
14.0	45.0				
16.0	42.2	44.4			
18.0	34.8	36.6	38.4		
20.0	29.2	30.8	32.3		
22.0	24.9	26.3	27.6	29.4	
24.0	21.5	22.7	23.8	25.3	22.1
26.0	18.7	19.7	20.7	22.0	21.7
28.0	16.3	17.2	18.1	19.2	19.9
30.0	14.3	15.1	15.9	16.8	17.4
32.0	12.6	13.3	13.9	14.7	15.1
34.0	11.1	11.7	12.3	12.9	
36.0	9.9	10.4	10.8	11.3	
38.0	8.7	9.2	9.5	9.8	
40.0	7.7	8.1	8.3		
42.0	6.8	7.1	7.2		
44.0	6.0	6.2			
46.0	5.2				
掛数	4	4	4	4	4
危険角度 (°)	10	20	30	45	60
フック種類	83t	83t	83t	83t	83t
フック質量 (t)	1.00	1.00	1.00	1.00	1.00

HC性能

18.15mブーム+4.4m+22mヘビーリフトジブ

オフセット	10°	20°	30°	45°	60°
作業半径 (m)	荷重 (ton)	荷重 (ton)	荷重 (ton)	荷重 (ton)	荷重 (ton)
10.0	50.0				
11.0	50.0				
12.0	50.0				
14.0	50.0	49.4			
16.0	43.2	45.0			
18.0	35.8	37.4	36.4		
20.0	30.3	31.6	32.9		
22.0	26.0	27.1	28.2	28.2	
24.0	22.5	23.5	24.4	25.7	20.6
26.0	19.7	20.5	21.3	22.4	20.2
28.0	17.4	18.1	18.8	19.7	19.9
30.0	15.4	16.0	16.6	17.3	17.7
32.0	13.7	14.2	14.7	15.3	
34.0	12.2	12.7	13.1	13.5	
36.0	10.9	11.3	11.6		
38.0	9.8	10.1	10.3		
40.0	8.8	9.0			
42.0	7.9				
掛数	6	6	6	6	6
危険角度 (°)	10	20	30	45	60
フック種類	83t	83t	83t	83t	83t
フック質量 (t)	1.00	1.00	1.00	1.00	1.00

HC性能

31.8mブーム+4.4m+22mヘビーリフトジブ

オフセット	10°	20°	30°	45°	60°
作業半径 (m)	荷重 (ton)	荷重 (ton)	荷重 (ton)	荷重 (ton)	荷重 (ton)
14.0	30.0				
16.0	30.0	29.8			
18.0	30.0	28.9			
20.0	28.6	28.0	25.2		
22.0	24.3	25.8	24.6		
24.0	20.8	22.2	23.4	20.6	
26.0	18.0	19.2	20.3	20.3	17.0
28.0	15.7	16.7	17.7	19.0	16.9
30.0	13.7	14.7	15.5	16.6	16.9
32.0	12.0	12.9	13.6	14.6	15.2
34.0	10.6	11.3	12.0	12.8	13.3
36.0	9.3	9.9	10.5	11.3	11.6
38.0	8.1	8.7	9.3	9.9	
40.0	7.1	7.7	8.1	8.6	
42.0	6.2	6.7	7.1	7.5	
44.0	5.4	5.8	6.2	6.4	
46.0	4.4	4.9	5.3		
48.0	3.5	4.0	4.3		
50.0		3.1	3.2		
掛数	4	4	4	4	4
危険角度 (°)	24	24	30	45	60
フック種類	83t	83t	83t	83t	83t
フック質量 (t)	1.00	1.00	1.00	1.00	1.00

HC性能

40.9mブーム+4.4m+22mヘビーリフトジブ

オフセット	10°	20°	30°	45°	60°
作業半径 (m)	荷重 (ton)	荷重 (ton)	荷重 (ton)	荷重 (ton)	荷重 (ton)
16.0	20.0				
18.0	20.0				
20.0	20.0	20.0			
22.0	20.0	20.0	20.0		
24.0	20.0	20.0	20.0		
26.0	17.9	19.2	20.0	20.0	
28.0	15.5	16.7	17.7	19.1	20.0
30.0	13.6	14.6	15.5	16.7	17.6
32.0	11.9	12.8	13.6	14.7	15.4
34.0	10.4	11.2	12.0	12.9	13.5
36.0	9.1	9.9	10.5	11.4	11.9
38.0	8.0	8.6	9.3	10.0	10.4
40.0	6.9	7.6	8.1	8.8	9.1
42.0	6.0	6.6	7.1	7.7	
44.0	5.0	5.7	6.2	6.6	
46.0	4.1	4.8	5.3	5.7	
48.0	3.2	3.8	4.3	4.7	
50.0		2.9	3.3	3.7	
掛数	2	2	2	2	2
危険角度 (°)	40	41	41	45	60
フック種類	24t	24t	24t	24t	24t
フック質量 (t)	0.88	0.88	0.88	0.88	0.88

HC性能

50.0mブーム+4.4m+22mヘビーリフトジブ

オフセット	10°	20°	30°	45°	60°
作業半径 (m)	荷重 (ton)	荷重 (ton)	荷重 (ton)	荷重 (ton)	荷重 (ton)
18.0	11.0				
20.0	11.0				
22.0	11.0	11.0			
24.0	11.0	11.0	11.0		
26.0	11.0	11.0	11.0		
28.0	11.0	11.0	10.9	9.1	
30.0	11.0	11.0	10.8	9.1	7.5
32.0	11.0	11.0	10.6	9.0	7.5
34.0	10.0	10.9	10.5	9.0	7.5
36.0	8.7	9.6	10.3	8.9	7.5
38.0	7.6	8.4	9.1	8.9	7.5
40.0	6.6	7.3	7.9	8.7	7.5
42.0	5.6	6.3	6.9	7.6	7.5
44.0	4.5	5.4	6.0	6.6	6.9
46.0	3.6	4.4	5.1	5.7	
48.0	2.7	3.4	4.1	4.7	
50.0			3.1	3.7	
掛数	2	2	2	2	2
危険角度 (°)	50	50	51	51	60
フック種類	24t	24t	24t	24t	24t
フック質量 (t)	0.88	0.88	0.88	0.88	0.88

HC性能

45.5mブーム+4.4m+22mヘビーリフトジブ

オフセット	10°	20°	30°	45°	60°
作業半径 (m)	荷重 (ton)	荷重 (ton)	荷重 (ton)	荷重 (ton)	荷重 (ton)
16.0	16.0				
18.0	16.0				
20.0	16.0	16.0			
22.0	16.0	16.0			
24.0	16.0	16.0	16.0		
26.0	16.0	16.0	16.0		
28.0	15.4	16.0	16.0	15.6	
30.0	13.4	14.4	15.4	15.4	13.0
32.0	11.7	12.6	13.5	14.6	13.0
34.0	10.2	11.1	11.9	12.9	12.9
36.0	8.9	9.7	10.4	11.3	11.9
38.0	7.8	8.5	9.2	9.9	10.4
40.0	6.8	7.4	8.0	8.7	9.1
42.0	5.9	6.5	7.0	7.6	7.9
44.0	4.8	5.6	6.1	6.6	
46.0	3.8	4.6	5.2	5.7	
48.0	2.9	3.6	4.2	4.8	
50.0		2.7	3.2	3.7	
掛数	2	2	2	2	2
危険角度 (°)	46	46	47	47	60
フック種類	24t	24t	24t	24t	24t
フック質量 (t)	0.88	0.88	0.88	0.88	0.88

HC性能

13.6mブーム+4.4m+31mヘビーリフトジブ

オフセット	10°	20°	30°	45°	60°
作業半径 (m)	荷重 (ton)	荷重 (ton)	荷重 (ton)	荷重 (ton)	荷重 (ton)
14.0	35.0				
16.0	34.4				
18.0	34.4	33.8			
20.0	33.2	31.5			
22.0	28.7	29.1	26.1		
24.0	25.2	26.2	24.5		
26.0	22.3	23.2	23.1		
28.0	19.9	20.7	21.5	18.8	
30.0	17.9	18.6	19.3	18.0	
32.0	16.2	16.8	17.4	17.3	12.7
34.0	14.7	15.2	15.7	16.5	12.4
36.0	13.3	13.8	14.3	14.9	12.2
38.0	12.2	12.6	13.0	13.5	
40.0	11.2	11.5	11.8	12.2	
42.0	10.2	10.5	10.7		
44.0	9.4	9.6	9.7		
46.0	8.7				
掛数	4	4	4	4	4
危険角度 (°)	10	20	30	45	60
フック種類	83t	83t	83t	83t	83t
フック質量 (t)	1.00	1.00	1.00	1.00	1.00

HC性能

22.7mブーム+4.4m+31mヘビーリフトジブ

オフセット	10°	20°	30°	45°	60°
作業半径 (m)	荷重 (ton)	荷重 (ton)	荷重 (ton)	荷重 (ton)	荷重 (ton)
16.0	30.0				
18.0	30.0				
20.0	30.0	30.0			
22.0	26.4	28.2			
24.0	22.8	24.4	25.8		
26.0	20.0	21.4	22.8		
28.0	17.6	18.8	20.1		
30.0	15.5	16.7	17.8	19.3	
32.0	13.8	14.8	15.8	17.2	
34.0	12.3	13.2	14.1	15.3	14.5
36.0	11.0	11.8	12.6	13.7	14.2
38.0	9.8	10.5	11.3	12.2	12.9
40.0	8.8	9.4	10.1	10.9	11.4
42.0	7.8	8.4	9.0	9.7	
44.0	7.0	7.5	8.0	8.6	
46.0	6.3	6.7	7.1	7.6	
48.0	5.6	6.0	6.3		
50.0	5.0	5.3	5.5		
55.0	3.2				
掛数	4	4	4	4	4
危険角度 (°)	10	20	30	45	60
フック種類	83t	83t	83t	83t	83t
フック質量 (t)	1.00	1.00	1.00	1.00	1.00

HC性能

18.15mブーム+4.4m+31mヘビーリフトジブ

オフセット	10°	20°	30°	45°	60°
作業半径 (m)	荷重 (ton)	荷重 (ton)	荷重 (ton)	荷重 (ton)	荷重 (ton)
14.0	34.0				
16.0	34.0				
18.0	34.0	34.0			
20.0	31.9	32.8			
22.0	27.5	29.0	26.8		
24.0	23.9	25.3	25.2		
26.0	21.1	22.2	23.4		
28.0	18.7	19.7	20.7	19.8	
30.0	16.6	17.6	18.5	19.1	
32.0	14.9	15.7	16.5	17.7	13.9
34.0	13.4	14.1	14.8	15.9	13.6
36.0	12.1	12.7	13.4	14.2	13.4
38.0	10.9	11.5	12.0	12.8	13.2
40.0	9.9	10.4	10.9	11.5	
42.0	8.9	9.4	9.8	10.3	
44.0	8.1	8.5	8.8	9.2	
46.0	7.4	7.7	7.9		
48.0	6.7	6.9	7.0		
50.0	6.1				
掛数	4	4	4	4	4
危険角度 (°)	10	20	30	45	60
フック種類	83t	83t	83t	83t	83t
フック質量 (t)	1.00	1.00	1.00	1.00	1.00

HC性能

31.8mブーム+4.4m+31mヘビーリフトジブ

オフセット	10°	20°	30°	45°	60°
作業半径 (m)	荷重 (ton)	荷重 (ton)	荷重 (ton)	荷重 (ton)	荷重 (ton)
16.0	20.0				
18.0	20.0				
20.0	20.0				
22.0	20.0	20.0			
24.0	20.0	20.0			
26.0	19.6	20.0	19.4		
28.0	17.2	18.6	18.9		
30.0	15.1	16.4	17.7	15.6	
32.0	13.4	14.6	15.7	15.3	
34.0	11.9	12.9	13.9	15.1	12.4
36.0	10.5	11.5	12.4	13.7	12.3
38.0	9.4	10.3	11.1	12.2	12.3
40.0	8.3	9.1	9.9	10.9	11.6
42.0	7.4	8.1	8.8	9.7	10.3
44.0	6.6	7.2	7.9	8.6	9.1
46.0	5.8	6.4	7.0	7.6	8.0
48.0	5.1	5.7	6.2	6.7	
50.0	4.3	5.0	5.4	5.9	
55.0		3.0	3.4		
掛数	2	2	2	2	2
危険角度 (°)	33	33	34	45	60
フック種類	24t	24t	24t	24t	24t
フック質量 (t)	0.88	0.88	0.88	0.88	0.88

HC性能

40.9mブーム+4.4m+31mヘビーリフトジブ

オフセット	10°	20°	30°	45°	60°
作業半径 (m)	荷重 (ton)	荷重 (ton)	荷重 (ton)	荷重 (ton)	荷重 (ton)
18.0	14.0				
20.0	14.0				
22.0	14.0				
24.0	14.0	14.0			
26.0	14.0	14.0			
28.0	14.0	14.0	14.0		
30.0	14.0	14.0	14.0		
32.0	12.9	14.0	14.0		
34.0	11.4	12.5	13.6	14.0	
36.0	10.0	11.1	12.1	13.5	
38.0	8.9	9.9	10.8	12.0	13.0
40.0	7.8	8.7	9.6	10.7	11.5
42.0	6.9	7.7	8.5	9.5	10.2
44.0	6.1	6.8	7.6	8.5	9.1
46.0	5.3	6.0	6.7	7.5	8.0
48.0	4.4	5.3	5.9	6.6	7.0
50.0	3.5	4.4	5.1	5.8	6.1
55.0				3.7	
掛数	2	2	2	2	2
危険角度 (°)	46	47	47	48	60
フック種類	24t	24t	24t	24t	24t
フック質量 (t)	0.88	0.88	0.88	0.88	0.88

HC性能

50.0mブーム+4.4m+31mヘビーリフトジブ

オフセット	10°	20°	30°	45°	60°
作業半径 (m)	荷重 (ton)	荷重 (ton)	荷重 (ton)	荷重 (ton)	荷重 (ton)
20.0	9.0				
22.0	9.0				
24.0	9.0				
26.0	9.0	9.0			
28.0	9.0	9.0			
30.0	9.0	9.0	7.8		
32.0	9.0	8.8	7.7		
34.0	9.0	8.6	7.5		
36.0	9.0	8.4	7.4	6.0	
38.0	8.4	8.2	7.3	5.9	4.7
40.0	7.4	8.1	7.2	5.9	4.6
42.0	6.5	7.4	7.1	5.8	4.6
44.0	5.6	6.5	7.0	5.8	4.6
46.0	4.7	5.7	6.4	5.8	4.6
48.0	3.7	4.8	5.6	5.8	4.6
50.0		3.9	4.9	5.7	4.6
55.0				3.6	
掛数	2	2	2	2	2
危険角度 (°)	55	56	56	56	60
フック種類	24t	24t	24t	24t	24t
フック質量 (t)	0.88	0.88	0.88	0.88	0.88

HC性能

45.5mブーム+4.4m+31mヘビーリフトジブ

オフセット	10°	20°	30°	45°	60°
作業半径 (m)	荷重 (ton)	荷重 (ton)	荷重 (ton)	荷重 (ton)	荷重 (ton)
20.0	12.0				
22.0	12.0				
24.0	12.0	12.0			
26.0	12.0	12.0			
28.0	12.0	12.0			
30.0	12.0	12.0	12.0		
32.0	12.0	12.0	12.0		
34.0	11.1	12.0	12.0	11.1	
36.0	9.8	10.9	12.0	11.0	
38.0	8.6	9.7	10.6	10.9	8.9
40.0	7.6	8.6	9.5	10.6	8.9
42.0	6.7	7.6	8.4	9.5	8.8
44.0	5.8	6.7	7.4	8.4	8.8
46.0	4.9	5.8	6.5	7.4	8.0
48.0	4.0	5.1	5.7	6.5	7.0
50.0	3.2	4.2	5.0	5.7	6.1
55.0			2.9	3.7	
掛数	2	2	2	2	2
危険角度 (°)	50	51	51	52	60
フック種類	24t	24t	24t	24t	24t
フック質量 (t)	0.88	0.88	0.88	0.88	0.88

HC性能

13.6mブーム+4.4m+40mヘビーリフトジブ

オフセット	10°	20°	30°	45°	60°
作業半径 (m)	荷重 (ton)	荷重 (ton)	荷重 (ton)	荷重 (ton)	荷重 (ton)
16.0	12.0				
18.0	12.0				
20.0	12.0				
22.0	12.0	12.0			
24.0	12.0	12.0			
26.0	12.0	12.0			
28.0	12.0	12.0	12.0		
30.0	12.0	12.0	12.0		
32.0	12.0	12.0	12.0		
34.0	12.0	12.0	12.0		
36.0	12.0	12.0	12.0	11.8	
38.0	12.0	12.0	12.0	11.2	
40.0	12.0	12.0	11.9	10.7	9.4
42.0	11.2	11.7	11.3	10.2	9.2
44.0	10.3	10.7	10.7	9.8	9.0
46.0	9.6	9.9	10.3	9.5	8.9
48.0	8.8	9.2	9.5	9.2	
50.0	8.2	8.5	8.7	9.0	
55.0	6.8				
掛数	1	1	1	1	1
危険角度 (°)	10	20	30	45	60
フック種類	12t	12t	12t	12t	12t
フック質量 (t)	0.53	0.53	0.53	0.53	0.53

HC性能

22.7mブーム+4.4m+40mヘビーリフトジブ

オフセット	10°	20°	30°	45°	60°
作業半径 (m)	荷重 (ton)	荷重 (ton)	荷重 (ton)	荷重 (ton)	荷重 (ton)
18.0	12.0				
20.0	12.0				
22.0	12.0				
24.0	12.0	12.0			
26.0	12.0	12.0			
28.0	12.0	12.0			
30.0	12.0	12.0	12.0		
32.0	12.0	12.0	12.0		
34.0	12.0	12.0	12.0		
36.0	12.0	12.0	12.0	12.0	
38.0	11.2	12.0	12.0	11.7	
40.0	10.1	11.0	11.9	11.3	
42.0	9.1	10.0	10.8	10.8	9.7
44.0	8.3	9.0	9.8	10.5	9.5
46.0	7.5	8.2	8.9	9.8	9.3
48.0	6.8	7.4	8.0	8.8	9.1
50.0	6.1	6.7	7.3	8.0	8.4
55.0	4.7	5.2	5.5	6.0	
60.0	3.3	3.7	3.9		
掛数	1	1	1	1	1
危険角度 (°)	10	20	30	45	60
フック種類	12t	12t	12t	12t	12t
フック質量 (t)	0.53	0.53	0.53	0.53	0.53

HC性能

18.15mブーム+4.4m+40mヘビーリフトジブ

オフセット	10°	20°	30°	45°	60°
作業半径 (m)	荷重 (ton)	荷重 (ton)	荷重 (ton)	荷重 (ton)	荷重 (ton)
18.0	12.0				
20.0	12.0				
22.0	12.0				
24.0	12.0	12.0			
26.0	12.0	12.0			
28.0	12.0	12.0			
30.0	12.0	12.0	12.0		
32.0	12.0	12.0	12.0		
34.0	12.0	12.0	12.0		
36.0	12.0	12.0	12.0	12.0	
38.0	12.0	12.0	12.0	11.5	
40.0	11.0	11.8	12.0	11.0	9.9
42.0	10.1	10.8	11.4	10.6	9.6
44.0	9.2	9.8	10.4	10.2	9.3
46.0	8.5	9.0	9.5	9.8	9.2
48.0	7.8	8.2	8.7	9.3	9.0
50.0	7.1	7.5	7.9	8.5	
55.0	5.7	6.0	6.2		
60.0	4.5				
掛数	1	1	1	1	1
危険角度 (°)	10	20	30	45	60
フック種類	12t	12t	12t	12t	12t
フック質量 (t)	0.53	0.53	0.53	0.53	0.53

HC性能

31.8mブーム+4.4m+40mヘビーリフトジブ

オフセット	10°	20°	30°	45°	60°
作業半径 (m)	荷重 (ton)	荷重 (ton)	荷重 (ton)	荷重 (ton)	荷重 (ton)
20.0	12.0				
22.0	12.0				
24.0	12.0				
26.0	12.0	12.0			
28.0	12.0	12.0			
30.0	12.0	12.0			
32.0	12.0	12.0	12.0		
34.0	12.0	12.0	12.0		
36.0	11.7	12.0	12.0		
38.0	10.5	11.6	12.0	12.0	
40.0	9.5	10.5	11.5	11.7	
42.0	8.5	9.5	10.4	11.3	
44.0	7.6	8.5	9.4	10.6	9.5
46.0	6.9	7.7	8.5	9.6	9.4
48.0	6.2	6.9	7.7	8.6	9.3
50.0	5.5	6.2	6.9	7.8	8.4
55.0	3.9	4.7	5.2	5.9	6.2
60.0	2.4	3.0	3.6	4.2	
65.0		1.5	1.9		
掛数	1	1	1	1	1
危険角度 (°)	32	33	33	45	60
フック種類	12t	12t	12t	12t	12t
フック質量 (t)	0.53	0.53	0.53	0.53	0.53

HC性能

40.9mブーム+4.4m+40mヘビーリフトジブ

オフセット	10°	20°	30°	45°	60°
作業半径 (m)	荷重 (ton)	荷重 (ton)	荷重 (ton)	荷重 (ton)	荷重 (ton)
22.0	11.0				
24.0	11.0				
26.0	11.0				
28.0	11.0	11.0			
30.0	11.0	11.0			
32.0	11.0	11.0			
34.0	11.0	11.0	11.0		
36.0	11.0	11.0	11.0		
38.0	10.0	11.0	11.0		
40.0	8.9	10.1	11.0		
42.0	8.0	9.1	10.1	11.0	
44.0	7.1	8.1	9.1	10.4	
46.0	6.3	7.3	8.2	9.4	9.6
48.0	5.6	6.5	7.3	8.5	9.3
50.0	5.0	5.8	6.6	7.6	8.4
55.0	3.1	4.1	4.9	5.7	6.3
60.0	1.6	2.4	3.2	4.1	
65.0			1.6	2.2	
掛数	1	1	1	1	1
危険角度 (°)	45	46	47	47	60
フック種類	12t	12t	12t	12t	12t
フック質量 (t)	0.53	0.53	0.53	0.53	0.53

HC性能

50.0mブーム+4.4m+40mヘビーリフトジブ

オフセット	10°	20°	30°	45°	60°
作業半径 (m)	荷重 (ton)	荷重 (ton)	荷重 (ton)	荷重 (ton)	荷重 (ton)
24.0	7.0				
26.0	7.0				
28.0	7.0				
30.0	7.0	7.0			
32.0	7.0	7.0			
34.0	7.0	7.0			
36.0	7.0	6.8	5.9		
38.0	7.0	6.7	5.8		
40.0	7.0	6.5	5.6		
42.0	7.0	6.4	5.5		
44.0	6.7	6.2	5.4	4.3	
46.0	5.9	6.1	5.3	4.2	
48.0	5.2	6.0	5.2	4.2	3.1
50.0	4.3	5.4	5.2	4.1	3.1
55.0		3.6	4.6	4.1	3.1
60.0			2.8	3.9	3.1
65.0				2.1	
掛数	1	1	1	1	1
危険角度 (°)	56	57	57	57	60
フック種類	12t	12t	12t	12t	12t
フック質量 (t)	0.53	0.53	0.53	0.53	0.53

HC性能

45.5mブーム+4.4m+40mヘビーリフトジブ

オフセット	10°	20°	30°	45°	60°
作業半径 (m)	荷重 (ton)	荷重 (ton)	荷重 (ton)	荷重 (ton)	荷重 (ton)
24.0	10.0				
26.0	10.0				
28.0	10.0				
30.0	10.0	10.0			
32.0	10.0	10.0			
34.0	10.0	10.0			
36.0	10.0	10.0	10.0		
38.0	9.8	10.0	10.0		
40.0	8.7	9.9	10.0		
42.0	7.7	8.9	10.0	8.5	
44.0	6.9	7.9	8.9	8.3	
46.0	6.1	7.1	8.0	8.2	6.6
48.0	5.4	6.3	7.2	8.1	6.5
50.0	4.6	5.6	6.4	7.5	6.5
55.0	2.8	3.9	4.8	5.7	6.2
60.0		2.2	3.0	4.0	4.5
65.0				2.2	
掛数	1	1	1	1	1
危険角度 (°)	51	52	52	53	60
フック種類	12t	12t	12t	12t	12t
フック質量 (t)	0.53	0.53	0.53	0.53	0.53

HC性能

13.6mブーム+4.4m+47mヘビーリフトジブ

オフセット	10°	20°	30°	45°	60°
作業半径 (m)	荷重 (ton)	荷重 (ton)	荷重 (ton)	荷重 (ton)	荷重 (ton)
18.0	12.0				
20.0	12.0				
22.0	12.0				
24.0	12.0				
26.0	12.0	12.0			
28.0	12.0	12.0			
30.0	12.0	12.0			
32.0	12.0	12.0	12.0		
34.0	12.0	12.0	12.0		
36.0	12.0	12.0	11.7		
38.0	12.0	12.0	10.9		
40.0	12.0	11.2	10.3		
42.0	11.5	10.5	9.7	8.6	
44.0	10.6	9.9	9.2	8.2	
46.0	9.8	9.4	8.7	7.8	7.1
48.0	9.1	8.8	8.2	7.5	6.9
50.0	8.5	8.4	7.9	7.2	6.7
55.0	7.1	7.4	7.1	6.6	
60.0	5.9	6.1	6.2		
掛数	1	1	1	1	1
危険角度 (°)	10	20	30	45	60
フック種類	12t	12t	12t	12t	12t
フック質量 (t)	0.53	0.53	0.53	0.53	0.53

HC性能

22.7mブーム+4.4m+47mヘビーリフトジブ

オフセット	10°	20°	30°	45°	60°
作業半径 (m)	荷重 (ton)	荷重 (ton)	荷重 (ton)	荷重 (ton)	荷重 (ton)
20.0	12.0				
22.0	12.0				
24.0	12.0				
26.0	12.0				
28.0	12.0	12.0			
30.0	12.0	12.0			
32.0	12.0	12.0			
34.0	12.0	12.0	12.0		
36.0	12.0	12.0	12.0		
38.0	11.7	12.0	11.7		
40.0	10.6	11.6	11.1		
42.0	9.6	10.6	10.5	8.9	
44.0	8.8	9.6	10.0	8.6	
46.0	8.0	8.8	9.5	8.2	
48.0	7.2	8.0	8.8	7.9	7.1
50.0	6.6	7.3	8.0	7.6	6.9
55.0	5.2	5.8	6.3	7.0	6.5
60.0	3.9	4.5	4.9	5.4	
65.0	2.6	3.1	3.5		
70.0	1.4	1.6			
掛数	1	1	1	1	1
危険角度 (°)	14	20	30	45	60
フック種類	12t	12t	12t	12t	12t
フック質量 (t)	0.53	0.53	0.53	0.53	0.53

HC性能

18.15mブーム+4.4m+47mヘビーリフトジブ

オフセット	10°	20°	30°	45°	60°
作業半径 (m)	荷重 (ton)	荷重 (ton)	荷重 (ton)	荷重 (ton)	荷重 (ton)
20.0	12.0				
22.0	12.0				
24.0	12.0				
26.0	12.0	12.0			
28.0	12.0	12.0			
30.0	12.0	12.0			
32.0	12.0	12.0			
34.0	12.0	12.0	12.0		
36.0	12.0	12.0	12.0		
38.0	12.0	12.0	11.3		
40.0	11.5	12.0	10.7		
42.0	10.5	11.2	10.1	8.8	
44.0	9.6	10.3	9.6	8.4	
46.0	8.8	9.5	9.1	8.0	
48.0	8.1	8.7	8.7	7.7	7.0
50.0	7.5	8.0	8.3	7.4	6.8
55.0	6.1	6.5	6.9	6.8	6.5
60.0	4.9	5.2	5.5	5.8	
65.0	3.9	4.1			
掛数	1	1	1	1	1
危険角度 (°)	10	20	30	45	60
フック種類	12t	12t	12t	12t	12t
フック質量 (t)	0.53	0.53	0.53	0.53	0.53

HC性能

31.8mブーム+4.4m+47mヘビーリフトジブ

オフセット	10°	20°	30°	45°	60°
作業半径 (m)	荷重 (ton)	荷重 (ton)	荷重 (ton)	荷重 (ton)	荷重 (ton)
22.0	12.0				
24.0	12.0				
26.0	12.0				
28.0	12.0				
30.0	12.0	12.0			
32.0	12.0	12.0			
34.0	12.0	12.0			
36.0	12.0	12.0	12.0		
38.0	11.0	12.0	12.0		
40.0	9.9	11.1	11.8		
42.0	9.0	10.1	11.2		
44.0	8.1	9.1	10.2	8.8	
46.0	7.3	8.3	9.2	8.5	
48.0	6.6	7.5	8.4	8.2	
50.0	5.9	6.8	7.6	8.0	7.0
55.0	4.5	5.2	5.9	6.9	6.7
60.0	3.0	3.8	4.5	5.2	5.7
65.0	1.7	2.4	3.0	3.8	
70.0			1.6	2.0	
掛数	1	1	1	1	1
危険角度 (°)	38	39	40	45	60
フック種類	12t	12t	12t	12t	12t
フック質量 (t)	0.53	0.53	0.53	0.53	0.53

HC性能

40.9mブーム+4.4m+47mヘビーリフトジブ

オフセット	10°	20°	30°	45°	60°
作業半径 (m)	荷重 (ton)	荷重 (ton)	荷重 (ton)	荷重 (ton)	荷重 (ton)
26.0	8.0				
28.0	8.0				
30.0	8.0				
32.0	8.0	8.0			
34.0	8.0	8.0			
36.0	8.0	8.0			
38.0	8.0	8.0			
40.0	8.0	8.0	8.0		
42.0	8.0	8.0	8.0		
44.0	7.5	8.0	8.0		
46.0	6.8	7.9	8.0		
48.0	6.0	7.1	8.0	8.0	
50.0	5.4	6.4	7.3	8.0	
55.0	3.7	4.8	5.6	6.7	6.8
60.0	2.2	3.2	4.2	5.1	5.7
65.0		1.7	2.6	3.6	4.1
70.0				1.9	
掛数	1	1	1	1	1
危険角度 (°)	49	50	51	51	60
フック種類	12t	12t	12t	12t	12t
フック質量 (t)	0.53	0.53	0.53	0.53	0.53

HC性能

50.0mブーム+4.4m+47mヘビーリフトジブ

オフセット	10°	20°	30°	45°	60°
作業半径 (m)	荷重 (ton)	荷重 (ton)	荷重 (ton)	荷重 (ton)	荷重 (ton)
26.0	5.0				
28.0	5.0				
30.0	5.0				
32.0	5.0				
34.0	5.0	5.0			
36.0	5.0	5.0			
38.0	5.0	5.0			
40.0	5.0	5.0	4.5		
42.0	5.0	5.0	4.4		
44.0	5.0	5.0	4.3		
46.0	5.0	4.9	4.2		
48.0	5.0	4.8	4.1	3.1	
50.0	4.9	4.7	4.0	3.0	
55.0		4.4	3.8	2.9	2.0
60.0		2.7	3.7	2.8	2.0
65.0				2.8	2.0
70.0					2.0
掛数	1	1	1	1	1
危険角度 (°)	59	59	60	60	60
フック種類	12t	12t	12t	12t	12t
フック質量 (t)	0.53	0.53	0.53	0.53	0.53

HC性能

45.5mブーム+4.4m+47mヘビーリフトジブ

オフセット	10°	20°	30°	45°	60°
作業半径 (m)	荷重 (ton)	荷重 (ton)	荷重 (ton)	荷重 (ton)	荷重 (ton)
26.0	7.5				
28.0	7.5				
30.0	7.5				
32.0	7.5				
34.0	7.5	7.5			
36.0	7.5	7.5			
38.0	7.5	7.5			
40.0	7.5	7.5	7.5		
42.0	7.5	7.5	7.5		
44.0	7.3	7.5	7.5		
46.0	6.5	7.5	7.5		
48.0	5.8	6.9	7.5	6.7	
50.0	5.1	6.2	7.1	6.6	
55.0	3.3	4.6	5.4	6.4	4.9
60.0		2.9	4.0	5.0	4.9
65.0			2.4	3.5	4.1
70.0				1.8	
掛数	1	1	1	1	1
危険角度 (°)	54	55	56	56	60
フック種類	12t	12t	12t	12t	12t
フック質量 (t)	0.53	0.53	0.53	0.53	0.53

HC性能

13.6mブーム+4.4m+54mヘビーリフトジブ

オフセット	10°	20°	30°	45°	60°
作業半径 (m)	荷重 (ton)	荷重 (ton)	荷重 (ton)	荷重 (ton)	荷重 (ton)
22.0	9.3				
24.0	9.3				
26.0	9.3				
28.0	9.3				
30.0	9.1	8.9			
32.0	9.1	8.8			
34.0	9.0	8.8			
36.0	8.9	8.6			
38.0	8.7	8.2	7.7		
40.0	8.4	7.9	7.4		
42.0	8.0	7.6	7.2		
44.0	7.7	7.3	6.9		
46.0	7.4	7.0	6.7	6.2	
48.0	7.1	6.8	6.5	6.1	
50.0	6.9	6.6	6.3	5.9	
55.0	6.3	6.1	5.9	5.4	4.9
60.0	5.8	5.6	5.3	4.9	4.6
65.0	5.1	5.0	4.8		
掛数	1	1	1	1	1
危険角度 (°)	10	20	30	45	60
フック種類	12t	12t	12t	12t	12t
フック質量 (t)	0.53	0.53	0.53	0.53	0.53

HC性能

22.7mブーム+4.4m+54mヘビーリフトジブ

オフセット	10°	20°	30°	45°	60°
作業半径 (m)	荷重 (ton)	荷重 (ton)	荷重 (ton)	荷重 (ton)	荷重 (ton)
24.0	9.3				
26.0	9.3				
28.0	9.3				
30.0	9.1				
32.0	9.1	8.9			
34.0	9.1	8.8			
36.0	9.0	8.7			
38.0	8.9	8.6	7.9		
40.0	8.8	8.3	7.7		
42.0	8.7	8.0	7.4		
44.0	8.4	7.7	7.2		
46.0	8.1	7.5	7.0		
48.0	7.6	7.2	6.8	6.2	
50.0	6.9	7.0	6.6	6.0	
55.0	5.5	6.2	6.2	5.7	5.1
60.0	4.3	4.9	5.5	5.2	4.8
65.0	3.1	3.8	4.3	4.8	4.6
70.0	2.0	2.5	3.0	3.5	
75.0		1.3	1.5		
掛数	1	1	1	1	1
危険角度 (°)	24	24	30	45	60
フック種類	12t	12t	12t	12t	12t
フック質量 (t)	0.53	0.53	0.53	0.53	0.53

HC性能

18.15mブーム+4.4m+54mヘビーリフトジブ

オフセット	10°	20°	30°	45°	60°
作業半径 (m)	荷重 (ton)	荷重 (ton)	荷重 (ton)	荷重 (ton)	荷重 (ton)
22.0	9.3				
24.0	9.3				
26.0	9.3				
28.0	9.3				
30.0	9.1	9.0			
32.0	9.1	9.0			
34.0	9.1	8.9			
36.0	8.9	8.8			
38.0	8.8	8.4	7.8		
40.0	8.7	8.1	7.6		
42.0	8.4	7.8	7.3		
44.0	8.0	7.5	7.1		
46.0	7.7	7.3	6.8		
48.0	7.5	7.0	6.6	6.1	
50.0	7.2	6.8	6.4	6.0	
55.0	6.3	6.3	6.0	5.5	5.0
60.0	5.2	5.6	5.6	5.0	4.7
65.0	4.2	4.5	4.9	4.7	
70.0	3.2	3.5	3.8		
掛数	1	1	1	1	1
危険角度 (°)	10	20	30	45	60
フック種類	12t	12t	12t	12t	12t
フック質量 (t)	0.53	0.53	0.53	0.53	0.53

HC性能

31.8mブーム+4.4m+54mヘビーリフトジブ

オフセット	10°	20°	30°	45°	60°
作業半径 (m)	荷重 (ton)	荷重 (ton)	荷重 (ton)	荷重 (ton)	荷重 (ton)
26.0	9.0				
28.0	9.0				
30.0	9.0				
32.0	9.0	8.9			
34.0	9.0	8.8			
36.0	9.0	8.7			
38.0	8.9	8.7			
40.0	8.8	8.7	7.9		
42.0	8.7	8.4	7.6		
44.0	8.5	8.1	7.4		
46.0	7.7	7.9	7.2		
48.0	6.9	7.6	7.0		
50.0	6.3	7.2	6.8	6.1	
55.0	4.8	5.7	6.4	5.8	
60.0	3.4	4.4	5.1	5.5	4.9
65.0	2.1	3.0	3.9	4.7	4.7
70.0		1.7	2.4	3.3	
75.0				1.7	
掛数	1	1	1	1	1
危険角度 (°)	45	45	45	45	60
フック種類	12t	12t	12t	12t	12t
フック質量 (t)	0.53	0.53	0.53	0.53	0.53

HC性能

40.9mブーム+4.4m+54mヘビーリフトジブ

オフセット	10°	20°	30°	45°	60°
作業半径 (m)	荷重 (ton)	荷重 (ton)	荷重 (ton)	荷重 (ton)	荷重 (ton)
28.0	6.0				
30.0	6.0				
32.0	6.0				
34.0	6.0				
36.0	6.0	6.0			
38.0	6.0	6.0			
40.0	6.0	6.0			
42.0	6.0	6.0			
44.0	6.0	6.0	6.0		
46.0	6.0	6.0	6.0		
48.0	6.0	6.0	6.0		
50.0	5.7	6.0	6.0		
55.0	4.2	5.2	6.0	5.9	
60.0	2.6	3.8	4.7	5.7	4.9
65.0		2.4	3.4	4.5	4.7
70.0			1.9	3.1	3.7
75.0				1.6	
掛数	1	1	1	1	1
危険角度 (°)	53	54	55	55	60
フック種類	12t	12t	12t	12t	12t
フック質量 (t)	0.53	0.53	0.53	0.53	0.53

HC性能

50.0mブーム+4.4m+54mヘビーリフトジブ

オフセット	10°	20°	30°	45°	60°
作業半径 (m)	荷重 (ton)	荷重 (ton)	荷重 (ton)	荷重 (ton)	荷重 (ton)
30.0	4.1				
32.0	4.1				
34.0	4.1				
36.0	4.1				
38.0	4.1	4.1			
40.0	4.1	4.1			
42.0	4.1	4.1			
44.0	4.1	4.0			
46.0	4.1	3.9	3.2		
48.0	4.1	3.8	3.1		
50.0	4.1	3.7	3.0		
55.0	3.5	3.4	2.8	2.0	
60.0		3.2	2.7	1.9	
65.0			2.6	1.8	
70.0				1.8	
掛数	1	1	1	1	1
危険角度 (°)	61	62	63	64	64
フック種類	12t	12t	12t	12t	12t
フック質量 (t)	0.53	0.53	0.53	0.53	0.53

HC性能

45.5mブーム+4.4m+54mヘビーリフトジブ

オフセット	10°	20°	30°	45°	60°
作業半径 (m)	荷重 (ton)	荷重 (ton)	荷重 (ton)	荷重 (ton)	荷重 (ton)
28.0	5.5				
30.0	5.5				
32.0	5.5				
34.0	5.5				
36.0	5.5	5.5			
38.0	5.5	5.5			
40.0	5.5	5.5			
42.0	5.5	5.5			
44.0	5.5	5.5	5.5		
46.0	5.5	5.5	5.5		
48.0	5.5	5.5	5.5		
50.0	5.5	5.5	5.5		
55.0	3.8	5.0	5.5	5.2	
60.0		3.5	4.6	5.0	3.7
65.0			3.1	4.4	3.6
70.0				2.9	3.6
75.0					2.0
掛数	1	1	1	1	1
危険角度 (°)	58	59	59	60	60
フック種類	12t	12t	12t	12t	12t
フック質量 (t)	0.53	0.53	0.53	0.53	0.53

HD性能

13.6mブーム+4.4m+13mヘビーリフトジブ

オフセット	10°	20°	30°	45°	60°
作業半径 (m)	荷重 (ton)	荷重 (ton)	荷重 (ton)	荷重 (ton)	荷重 (ton)
7.0	84.0				
8.0	84.0	84.0			
9.0	78.7	80.1			
10.0	69.6	71.6	65.8		
11.0	61.7	63.4	63.2		
12.0	53.3	54.8	56.2	50.9	
14.0	41.4	42.5	43.6	45.0	34.2
16.0	33.4	34.3	35.1	36.2	33.3
18.0	27.6	28.3	28.9	29.7	30.2
20.0	23.3	23.8	24.3	24.9	
22.0	19.9	20.3	20.6	21.0	
24.0	17.1	17.4	17.7		
26.0	14.9	15.1	15.2		
28.0	13.1				
掛数	8	8	8	8	8
危険角度 (°)	10	20	30	45	60
フック種類	150t	150t	150t	150t	150t
フック質量 (t)	1.86	1.86	1.86	1.86	1.86

HD性能

22.7mブーム+4.4m+13mヘビーリフトジブ

オフセット	10°	20°	30°	45°	60°
作業半径 (m)	荷重 (ton)	荷重 (ton)	荷重 (ton)	荷重 (ton)	荷重 (ton)
8.0	64.0				
9.0	64.0				
10.0	64.0	64.0			
11.0	58.1	60.6			
12.0	49.8	52.0	54.1		
14.0	38.1	39.8	41.4	43.5	
16.0	30.2	31.5	32.8	34.5	35.6
18.0	24.5	25.6	26.6	27.9	28.8
20.0	20.2	21.1	22.0	23.0	23.6
22.0	16.8	17.6	18.3	19.1	19.6
24.0	14.1	14.8	15.4	16.0	
26.0	11.9	12.5	12.9	13.4	
28.0	10.1	10.5	10.9	11.2	
30.0	8.5	8.9	9.1		
32.0	7.2	7.4	7.6		
34.0	6.0	6.2	6.3		
36.0	4.6	4.8			
掛数	6	6	6	6	6
危険角度 (°)	10	20	30	45	60
フック種類	83t	83t	83t	83t	83t
フック質量 (t)	1.00	1.00	1.00	1.00	1.00

HD性能

18.15mブーム+4.4m+13mヘビーリフトジブ

オフセット	10°	20°	30°	45°	60°
作業半径 (m)	荷重 (ton)	荷重 (ton)	荷重 (ton)	荷重 (ton)	荷重 (ton)
7.0	77.0				
8.0	77.0				
9.0	76.6	77.0			
10.0	67.5	69.9			
11.0	59.5	61.7	63.8		
12.0	51.2	53.1	54.9		
14.0	39.4	40.9	42.2	44.0	
16.0	31.5	32.6	33.7	35.1	36.1
18.0	25.7	26.7	27.5	28.6	29.3
20.0	21.4	22.2	22.9	23.7	24.2
22.0	18.1	18.7	19.2	19.9	
24.0	15.4	15.9	16.3	16.7	
26.0	13.2	13.5	13.9	14.1	
28.0	11.3	11.6	11.8		
30.0	9.8	9.9	10.0		
32.0	8.4				
掛数	8	8	8	8	8
危険角度 (°)	10	20	30	45	60
フック種類	150t	150t	150t	150t	150t
フック質量 (t)	1.86	1.86	1.86	1.86	1.86

HD性能

31.8mブーム+4.4m+13mヘビーリフトジブ

オフセット	10°	20°	30°	45°	60°
作業半径 (m)	荷重 (ton)	荷重 (ton)	荷重 (ton)	荷重 (ton)	荷重 (ton)
10.0	45.0				
11.0	44.8	40.3			
12.0	44.1	39.8			
14.0	37.9	38.8	35.3		
16.0	30.0	31.5	32.9	30.2	
18.0	24.3	25.6	26.7	28.1	25.8
20.0	20.0	21.1	22.0	23.2	24.0
22.0	16.7	17.6	18.4	19.3	19.9
24.0	14.0	14.7	15.4	16.2	16.7
26.0	11.7	12.4	13.0	13.7	14.0
28.0	9.9	10.5	11.0	11.5	11.7
30.0	8.3	8.8	9.3	9.7	
32.0	7.0	7.4	7.8	8.1	
34.0	5.7	6.2	6.5	6.7	
36.0	4.4	4.8	5.2		
38.0	3.2	3.5	3.8		
掛数	4	4	4	4	4
危険角度 (°)	34	34	34	45	60
フック種類	83t	83t	83t	83t	83t
フック質量 (t)	1.00	1.00	1.00	1.00	1.00

HD性能

13.6mブーム+4.4m+22mヘビーリフトジブ

オフセット	10°	20°	30°	45°	60°
作業半径 (m)	荷重 (ton)	荷重 (ton)	荷重 (ton)	荷重 (ton)	荷重 (ton)
10.0	54.0				
11.0	54.0				
12.0	54.0				
14.0	43.9	45.6			
16.0	35.6	37.0	38.0		
18.0	29.6	30.8	32.0		
20.0	25.1	26.1	27.1	28.1	
22.0	21.6	22.5	23.3	24.5	19.4
24.0	18.8	19.5	20.3	21.2	18.9
26.0	16.5	17.1	17.7	18.5	18.6
28.0	14.6	15.1	15.6	16.2	16.6
30.0	13.0	13.4	13.8	14.3	
32.0	11.6	11.9	12.2	12.5	
34.0	10.4	10.6	10.8		
36.0	9.3	9.5			
掛数	6	6	6	6	6
危険角度 (°)	10	20	30	45	60
フック種類	83t	83t	83t	83t	83t
フック質量 (t)	1.00	1.00	1.00	1.00	1.00

HD性能

22.7mブーム+4.4m+22mヘビーリフトジブ

オフセット	10°	20°	30°	45°	60°
作業半径 (m)	荷重 (ton)	荷重 (ton)	荷重 (ton)	荷重 (ton)	荷重 (ton)
11.0	45.0				
12.0	45.0				
14.0	41.2				
16.0	33.0	35.2			
18.0	27.1	28.9	30.6		
20.0	22.6	24.1	25.6		
22.0	19.1	20.4	21.7	23.5	
24.0	16.3	17.5	18.6	20.1	21.2
26.0	14.0	15.0	16.0	17.2	18.2
28.0	12.1	13.0	13.8	14.9	15.7
30.0	10.4	11.2	11.9	12.9	13.4
32.0	9.0	9.7	10.3	11.1	11.5
34.0	7.8	8.4	8.9	9.5	
36.0	6.7	7.2	7.7	8.2	
38.0	5.8	6.2	6.6	6.9	
40.0	4.8	5.3	5.6		
42.0	3.9	4.2	4.5		
44.0		3.2			
掛数	4	4	4	4	4
危険角度 (°)	15	20	30	45	60
フック種類	83t	83t	83t	83t	83t
フック質量 (t)	1.00	1.00	1.00	1.00	1.00

HD性能

18.15mブーム+4.4m+22mヘビーリフトジブ

オフセット	10°	20°	30°	45°	60°
作業半径 (m)	荷重 (ton)	荷重 (ton)	荷重 (ton)	荷重 (ton)	荷重 (ton)
10.0	50.0				
11.0	50.0				
12.0	50.0				
14.0	42.3	44.5			
16.0	34.0	35.8			
18.0	28.1	29.6	31.1		
20.0	23.6	24.9	26.2		
22.0	20.1	21.2	22.3	23.8	
24.0	17.3	18.3	19.2	20.5	20.6
26.0	15.0	15.8	16.6	17.7	18.5
28.0	13.1	13.8	14.5	15.4	16.0
30.0	11.5	12.1	12.7	13.4	13.8
32.0	10.1	10.6	11.1	11.6	
34.0	8.9	9.3	9.7	10.1	
36.0	7.8	8.2	8.5		
38.0	6.9	7.1	7.3		
40.0	6.1	6.2			
42.0	5.3				
掛数	6	6	6	6	6
危険角度 (°)	10	20	30	45	60
フック種類	83t	83t	83t	83t	83t
フック質量 (t)	1.00	1.00	1.00	1.00	1.00

HD性能

31.8mブーム+4.4m+22mヘビーリフトジブ

オフセット	10°	20°	30°	45°	60°
作業半径 (m)	荷重 (ton)	荷重 (ton)	荷重 (ton)	荷重 (ton)	荷重 (ton)
14.0	30.0				
16.0	30.0	29.8			
18.0	26.4	28.4			
20.0	22.0	23.7	25.2		
22.0	18.5	20.0	21.4		
24.0	15.7	17.0	18.2	19.9	
26.0	13.4	14.5	15.6	17.0	17.0
28.0	11.5	12.5	13.4	14.7	15.6
30.0	9.8	10.8	11.6	12.7	13.5
32.0	8.4	9.3	10.0	11.0	11.6
34.0	7.2	8.0	8.6	9.5	9.9
36.0	6.2	6.8	7.4	8.1	8.5
38.0	5.1	5.8	6.3	6.9	
40.0	4.0	4.8	5.4	5.9	
42.0	3.1	3.7	4.3	4.9	
44.0			3.2	3.6	
掛数	4	4	4	4	4
危険角度 (°)	42	42	42	45	60
フック種類	83t	83t	83t	83t	83t
フック質量 (t)	1.00	1.00	1.00	1.00	1.00

HD性能

40.9mブーム+4.4m+22mヘビーリフトジブ

オフセット	10°	20°	30°	45°	60°
作業半径 (m)	荷重 (ton)	荷重 (ton)	荷重 (ton)	荷重 (ton)	荷重 (ton)
16.0	20.0				
18.0	20.0				
20.0	20.0	20.0			
22.0	18.4	19.9	20.0		
24.0	15.5	16.9	18.2		
26.0	13.2	14.5	15.6	17.2	
28.0	11.3	12.4	13.5	14.8	15.8
30.0	9.7	10.7	11.6	12.8	13.7
32.0	8.3	9.2	10.0	11.1	11.8
34.0	7.0	7.9	8.6	9.6	10.2
36.0	6.0	6.7	7.4	8.2	8.7
38.0	4.8	5.7	6.3	7.1	7.5
40.0	3.7	4.6	5.4	6.0	6.3
42.0	2.7	3.6	4.3	5.0	
44.0			3.2	3.9	
46.0				2.8	
掛数	2	2	2	2	2
危険角度 (°)	50	51	51	52	60
フック種類	24t	24t	24t	24t	24t
フック質量 (t)	0.88	0.88	0.88	0.88	0.88

HD性能

50.0mブーム+4.4m+22mヘビーリフトジブ

オフセット	10°	20°	30°	45°	60°
作業半径 (m)	荷重 (ton)	荷重 (ton)	荷重 (ton)	荷重 (ton)	荷重 (ton)
18.0	11.0				
20.0	11.0				
22.0	11.0	11.0			
24.0	11.0	11.0	11.0		
26.0	11.0	11.0	11.0		
28.0	11.0	11.0	10.9	9.1	
30.0	9.3	10.4	10.8	9.1	7.5
32.0	7.9	8.9	9.8	9.0	7.5
34.0	6.7	7.6	8.4	9.0	7.5
36.0	5.6	6.5	7.2	8.1	7.5
38.0		5.4	6.1	7.0	7.5
40.0		4.2	5.2	5.9	6.3
42.0			4.0	5.0	5.3
44.0				3.8	4.2
掛数	2	2	2	2	2
危険角度 (°)	60	60	60	60	60
フック種類	24t	24t	24t	24t	24t
フック質量 (t)	0.88	0.88	0.88	0.88	0.88

HD性能

45.5mブーム+4.4m+22mヘビーリフトジブ

オフセット	10°	20°	30°	45°	60°
作業半径 (m)	荷重 (ton)	荷重 (ton)	荷重 (ton)	荷重 (ton)	荷重 (ton)
16.0	16.0				
18.0	16.0				
20.0	16.0	16.0			
22.0	16.0	16.0			
24.0	15.4	16.0	16.0		
26.0	13.0	14.3	15.5		
28.0	11.1	12.3	13.4	14.7	
30.0	9.5	10.5	11.5	12.7	13.0
32.0	8.1	9.0	9.9	11.0	11.8
34.0	6.9	7.7	8.5	9.5	10.2
36.0	5.8	6.6	7.3	8.2	8.7
38.0	4.6	5.6	6.2	7.0	7.5
40.0	3.5	4.4	5.3	6.0	6.3
42.0		3.4	4.1	5.0	5.3
44.0			3.1	3.9	
46.0				2.8	
掛数	2	2	2	2	2
危険角度 (°)	55	56	56	56	60
フック種類	24t	24t	24t	24t	24t
フック質量 (t)	0.88	0.88	0.88	0.88	0.88

HD性能

13.6mブーム+4.4m+31mヘビーリフトジブ

オフセット	10°	20°	30°	45°	60°
作業半径 (m)	荷重 (ton)	荷重 (ton)	荷重 (ton)	荷重 (ton)	荷重 (ton)
14.0	35.0				
16.0	34.4				
18.0	31.0	32.6			
20.0	26.4	27.8			
22.0	22.8	24.0	25.1		
24.0	20.0	21.0	22.0		
26.0	17.6	18.5	19.4		
28.0	15.6	16.4	17.2	18.3	
30.0	14.0	14.6	15.3	16.3	
32.0	12.5	13.1	13.7	14.6	12.7
34.0	11.3	11.8	12.3	13.1	12.4
36.0	10.2	10.6	11.1	11.7	12.2
38.0	9.2	9.6	10.0	10.5	
40.0	8.4	8.7	9.0	9.4	
42.0	7.6	7.9	8.1		
44.0	6.9	7.1	7.2		
46.0	6.3				
掛数	4	4	4	4	4
危険角度 (°)	10	20	30	45	60
フック種類	83t	83t	83t	83t	83t
フック質量 (t)	1.00	1.00	1.00	1.00	1.00

HD性能

22.7mブーム+4.4m+31mヘビーリフトジブ

オフセット	10°	20°	30°	45°	60°
作業半径 (m)	荷重 (ton)	荷重 (ton)	荷重 (ton)	荷重 (ton)	荷重 (ton)
16.0	30.0				
18.0	28.7				
20.0	24.1	26.1			
22.0	20.5	22.3			
24.0	17.6	19.2	20.7		
26.0	15.3	16.7	18.0		
28.0	13.3	14.5	15.7		
30.0	11.6	12.7	13.8	15.4	
32.0	10.2	11.2	12.2	13.5	
34.0	8.9	9.8	10.7	11.9	12.9
36.0	7.8	8.6	9.4	10.5	11.3
38.0	6.9	7.6	8.3	9.2	9.9
40.0	6.0	6.7	7.3	8.1	8.6
42.0	5.2	5.8	6.4	7.0	
44.0	4.5	5.0	5.5	6.1	
46.0	3.6	4.3	4.8	5.2	
48.0		3.4	3.9		
掛数	4	4	4	4	4
危険角度 (°)	30	30	30	45	60
フック種類	83t	83t	83t	83t	83t
フック質量 (t)	1.00	1.00	1.00	1.00	1.00

HD性能

18.15mブーム+4.4m+31mヘビーリフトジブ

オフセット	10°	20°	30°	45°	60°
作業半径 (m)	荷重 (ton)	荷重 (ton)	荷重 (ton)	荷重 (ton)	荷重 (ton)
14.0	34.0				
16.0	34.0				
18.0	29.8	31.7			
20.0	25.2	26.9			
22.0	21.6	23.1	24.5		
24.0	18.7	20.0	21.3		
26.0	16.3	17.5	18.6		
28.0	14.4	15.4	16.4	17.9	
30.0	12.7	13.6	14.5	15.8	
32.0	11.3	12.1	12.9	14.0	13.9
34.0	10.0	10.7	11.5	12.4	13.3
36.0	8.9	9.6	10.2	11.1	11.7
38.0	7.9	8.5	9.1	9.8	10.3
40.0	7.1	7.6	8.1	8.7	
42.0	6.3	6.8	7.2	7.6	
44.0	5.6	6.0	6.3	6.7	
46.0	5.0	5.3	5.5		
48.0	4.4	4.6	4.8		
50.0	3.8				
掛数	4	4	4	4	4
危険角度 (°)	10	20	30	45	60
フック種類	83t	83t	83t	83t	83t
フック質量 (t)	1.00	1.00	1.00	1.00	1.00

HD性能

31.8mブーム+4.4m+31mヘビーリフトジブ

オフセット	10°	20°	30°	45°	60°
作業半径 (m)	荷重 (ton)	荷重 (ton)	荷重 (ton)	荷重 (ton)	荷重 (ton)
16.0	20.0				
18.0	20.0				
20.0	20.0				
22.0	20.0	20.0			
24.0	17.3	19.0			
26.0	14.9	16.4	18.0		
28.0	12.9	14.3	15.7		
30.0	11.2	12.5	13.7	15.4	
32.0	9.8	10.9	12.0	13.5	
34.0	8.5	9.6	10.6	11.9	12.4
36.0	7.4	8.4	9.3	10.5	11.4
38.0	6.4	7.3	8.1	9.2	10.0
40.0	5.6	6.4	7.1	8.1	8.8
42.0	4.7	5.5	6.2	7.1	7.6
44.0	3.8	4.8	5.4	6.1	6.6
46.0	2.9	3.8	4.6	5.3	5.6
48.0		3.0	3.7	4.5	
50.0			2.8	3.5	
掛数	2	2	2	2	2
危険角度 (°)	47	48	49	49	60
フック種類	24t	24t	24t	24t	24t
フック質量 (t)	0.88	0.88	0.88	0.88	0.88

HD性能

40.9mブーム+4.4m+31mヘビーリフトジブ

オフセット	10°	20°	30°	45°	60°
作業半径 (m)	荷重 (ton)	荷重 (ton)	荷重 (ton)	荷重 (ton)	荷重 (ton)
18.0	14.0				
20.0	14.0				
22.0	14.0				
24.0	14.0	14.0			
26.0	14.0	14.0			
28.0	12.4	13.9	14.0		
30.0	10.7	12.1	13.4		
32.0	9.3	10.5	11.7		
34.0	8.0	9.2	10.3	11.7	
36.0	6.9	8.0	9.0	10.3	
38.0	5.9	6.9	7.8	9.1	10.0
40.0	5.0	6.0	6.8	7.9	8.7
42.0	4.0	5.1	5.9	6.9	7.6
44.0	3.0	4.2	5.1	6.0	6.6
46.0		3.3	4.2	5.1	5.6
48.0			3.3	4.3	4.8
50.0				3.4	3.8
掛数	2	2	2	2	2
危険角度 (°)	55	56	56	57	60
フック種類	24t	24t	24t	24t	24t
フック質量 (t)	0.88	0.88	0.88	0.88	0.88

HD性能

50.0mブーム+4.4m+31mヘビーリフトジブ

オフセット	10°	20°	30°	45°	60°
作業半径 (m)	荷重 (ton)	荷重 (ton)	荷重 (ton)	荷重 (ton)	荷重 (ton)
20.0	9.0				
22.0	9.0				
24.0	9.0				
26.0	9.0	9.0			
28.0	9.0	9.0			
30.0	9.0	9.0	7.8		
32.0	8.8	8.8	7.7		
34.0	7.6	8.6	7.5		
36.0	6.5	7.6	7.4	6.0	
38.0	5.5	6.6	7.3	5.9	4.7
40.0		5.6	6.6	5.9	4.6
42.0		4.7	5.6	5.8	4.6
44.0			4.8	5.8	4.6
46.0				5.0	4.6
48.0				4.1	4.6
50.0					3.9
掛数	2	2	2	2	2
危険角度 (°)	63	64	64	65	65
フック種類	24t	24t	24t	24t	24t
フック質量 (t)	0.88	0.88	0.88	0.88	0.88

HD性能

45.5mブーム+4.4m+31mヘビーリフトジブ

オフセット	10°	20°	30°	45°	60°
作業半径 (m)	荷重 (ton)	荷重 (ton)	荷重 (ton)	荷重 (ton)	荷重 (ton)
20.0	12.0				
22.0	12.0				
24.0	12.0	12.0			
26.0	12.0	12.0			
28.0	12.0	12.0			
30.0	10.5	11.9	12.0		
32.0	9.0	10.3	11.6		
34.0	7.8	9.0	10.1	11.1	
36.0	6.7	7.8	8.8	10.2	
38.0	5.7	6.7	7.7	9.0	8.9
40.0	4.7	5.8	6.7	7.8	8.7
42.0		4.9	5.8	6.8	7.6
44.0		3.9	4.9	5.9	6.5
46.0			4.0	5.1	5.6
48.0				4.2	4.8
50.0				3.3	3.9
掛数	2	2	2	2	2
危険角度 (°)	60	60	61	61	62
フック種類	24t	24t	24t	24t	24t
フック質量 (t)	0.88	0.88	0.88	0.88	0.88

HD性能

13.6mブーム+4.4m+40mヘビーリフトジブ

オフセット	10°	20°	30°	45°	60°
作業半径 (m)	荷重 (ton)	荷重 (ton)	荷重 (ton)	荷重 (ton)	荷重 (ton)
16.0	12.0				
18.0	12.0				
20.0	12.0				
22.0	12.0	12.0			
24.0	12.0	12.0			
26.0	12.0	12.0			
28.0	12.0	12.0	12.0		
30.0	12.0	12.0	12.0		
32.0	12.0	12.0	12.0		
34.0	12.0	12.0	12.0		
36.0	11.2	11.8	12.0	11.8	
38.0	10.2	10.8	11.4	11.2	
40.0	9.3	9.8	10.4	10.7	9.4
42.0	8.5	9.0	9.5	10.2	9.2
44.0	7.8	8.2	8.7	9.3	9.0
46.0	7.2	7.5	7.9	8.4	8.8
48.0	6.6	6.9	7.2	7.6	
50.0	6.0	6.3	6.5	6.8	
55.0	4.8				
掛数	1	1	1	1	1
危険角度 (°)	10	20	30	45	60
フック種類	12t	12t	12t	12t	12t
フック質量 (t)	0.53	0.53	0.53	0.53	0.53

HD性能

22.7mブーム+4.4m+40mヘビーリフトジブ

オフセット	10°	20°	30°	45°	60°
作業半径 (m)	荷重 (ton)	荷重 (ton)	荷重 (ton)	荷重 (ton)	荷重 (ton)
18.0	12.0				
20.0	12.0				
22.0	12.0				
24.0	12.0	12.0			
26.0	12.0	12.0			
28.0	12.0	12.0			
30.0	12.0	12.0	12.0		
32.0	11.6	12.0	12.0		
34.0	10.3	11.5	12.0		
36.0	9.2	10.3	11.3	12.0	
38.0	8.2	9.2	10.1	11.5	
40.0	7.3	8.2	9.1	10.3	
42.0	6.5	7.3	8.1	9.2	9.7
44.0	5.8	6.5	7.3	8.3	9.1
46.0	5.1	5.8	6.5	7.4	8.1
48.0	4.5	5.2	5.8	6.6	7.1
50.0	3.9	4.6	5.1	5.8	6.2
55.0	2.3	2.9	3.5	4.0	
60.0		1.4	1.7		
掛数	1	1	1	1	1
危険角度 (°)	27	27	30	45	60
フック種類	12t	12t	12t	12t	12t
フック質量 (t)	0.53	0.53	0.53	0.53	0.53

HD性能

18.15mブーム+4.4m+40mヘビーリフトジブ

オフセット	10°	20°	30°	45°	60°
作業半径 (m)	荷重 (ton)	荷重 (ton)	荷重 (ton)	荷重 (ton)	荷重 (ton)
18.0	12.0				
20.0	12.0				
22.0	12.0				
24.0	12.0	12.0			
26.0	12.0	12.0			
28.0	12.0	12.0			
30.0	12.0	12.0	12.0		
32.0	12.0	12.0	12.0		
34.0	11.3	12.0	12.0		
36.0	10.1	11.0	11.9	12.0	
38.0	9.1	9.9	10.7	11.5	
40.0	8.2	9.0	9.7	10.7	9.9
42.0	7.5	8.1	8.7	9.7	9.6
44.0	6.7	7.3	7.9	8.7	9.3
46.0	6.1	6.6	7.1	7.9	8.4
48.0	5.5	6.0	6.4	7.0	7.4
50.0	4.9	5.4	5.8	6.3	
55.0	3.7	4.0	4.3		
60.0	2.3				
掛数	1	1	1	1	1
危険角度 (°)	10	20	30	45	60
フック種類	12t	12t	12t	12t	12t
フック質量 (t)	0.53	0.53	0.53	0.53	0.53

HD性能

31.8mブーム+4.4m+40mヘビーリフトジブ

オフセット	10°	20°	30°	45°	60°
作業半径 (m)	荷重 (ton)	荷重 (ton)	荷重 (ton)	荷重 (ton)	荷重 (ton)
20.0	12.0				
22.0	12.0				
24.0	12.0				
26.0	12.0	12.0			
28.0	12.0	12.0			
30.0	12.0	12.0			
32.0	11.0	12.0	12.0		
34.0	9.7	11.0	12.0		
36.0	8.6	9.8	11.0		
38.0	7.6	8.7	9.8	11.3	
40.0	6.7	7.7	8.7	10.1	
42.0	5.9	6.8	7.8	9.0	
44.0	5.1	6.0	6.9	8.1	9.0
46.0	4.4	5.3	6.1	7.2	8.0
48.0	3.7	4.7	5.4	6.4	7.1
50.0	2.9	4.0	4.7	5.6	6.2
55.0	1.4	2.2	3.0	3.9	4.3
60.0			1.3	2.0	
掛数	1	1	1	1	1
危険角度 (°)	45	46	47	47	60
フック種類	12t	12t	12t	12t	12t
フック質量 (t)	0.53	0.53	0.53	0.53	0.53

HD性能

40.9mブーム+4.4m+40mヘビーリフトジブ

オフセット	10°	20°	30°	45°	60°
作業半径 (m)	荷重 (ton)	荷重 (ton)	荷重 (ton)	荷重 (ton)	荷重 (ton)
22.0	11.0				
24.0	11.0				
26.0	11.0				
28.0	11.0	11.0			
30.0	11.0	11.0			
32.0	10.5	11.0			
34.0	9.2	10.6	11.0		
36.0	8.0	9.4	10.7		
38.0	7.0	8.3	9.5		
40.0	6.1	7.3	8.4		
42.0	5.3	6.4	7.5	8.9	
44.0	4.5	5.6	6.6	7.9	
46.0	3.7	4.9	5.8	7.0	7.9
48.0	2.9	4.2	5.1	6.2	7.0
50.0		3.4	4.4	5.4	6.2
55.0			2.6	3.8	4.3
掛数	1	1	1	1	1
危険角度 (°)	56	57	57	58	60
フック種類	12t	12t	12t	12t	12t
フック質量 (t)	0.53	0.53	0.53	0.53	0.53

HD性能

50.0mブーム+4.4m+40mヘビーリフトジブ

オフセット	10°	20°	30°	45°	60°
作業半径 (m)	荷重 (ton)	荷重 (ton)	荷重 (ton)	荷重 (ton)	荷重 (ton)
24.0	7.0				
26.0	7.0				
28.0	7.0				
30.0	7.0	7.0			
32.0	7.0	7.0			
34.0	7.0	7.0			
36.0	7.0	6.8	5.9		
38.0	6.6	6.7	5.8		
40.0	5.7	6.5	5.6		
42.0	4.8	6.1	5.5		
44.0		5.3	5.4	4.3	
46.0		4.5	5.3	4.2	
48.0			4.8	4.2	3.1
50.0			4.1	4.1	3.1
55.0				3.5	3.1
掛数	1	1	1	1	1
危険角度 (°)	64	65	65	66	66
フック種類	12t	12t	12t	12t	12t
フック質量 (t)	0.53	0.53	0.53	0.53	0.53

HD性能

45.5mブーム+4.4m+40mヘビーリフトジブ

オフセット	10°	20°	30°	45°	60°
作業半径 (m)	荷重 (ton)	荷重 (ton)	荷重 (ton)	荷重 (ton)	荷重 (ton)
24.0	10.0				
26.0	10.0				
28.0	10.0				
30.0	10.0	10.0			
32.0	10.0	10.0			
34.0	8.9	10.0			
36.0	7.8	9.2	10.0		
38.0	6.8	8.1	9.3		
40.0	5.9	7.1	8.3		
42.0	5.1	6.2	7.3	8.5	
44.0	4.2	5.4	6.4	7.8	
46.0	3.3	4.7	5.7	6.9	6.6
48.0		3.9	4.9	6.1	6.5
50.0		3.1	4.3	5.3	6.2
55.0				3.6	4.3
60.0					2.3
掛数	1	1	1	1	1
危険角度 (°)	60	61	62	62	60
フック種類	12t	12t	12t	12t	12t
フック質量 (t)	0.53	0.53	0.53	0.53	0.53

HD性能

13.6mブーム+4.4m+47mヘビーリフトジブ

オフセット	10°	20°	30°	45°	60°
作業半径 (m)	荷重 (ton)	荷重 (ton)	荷重 (ton)	荷重 (ton)	荷重 (ton)
18.0	12.0				
20.0	12.0				
22.0	12.0				
24.0	12.0				
26.0	12.0	12.0			
28.0	12.0	12.0			
30.0	12.0	12.0			
32.0	12.0	12.0	12.0		
34.0	12.0	12.0	12.0		
36.0	11.5	12.0	11.7		
38.0	10.5	11.2	10.9		
40.0	9.6	10.2	10.3		
42.0	8.8	9.4	9.7	8.6	
44.0	8.1	8.6	9.2	8.2	
46.0	7.4	7.9	8.4	7.8	7.1
48.0	6.8	7.3	7.7	7.5	6.9
50.0	6.3	6.7	7.1	7.2	6.7
55.0	5.1	5.4	5.7	6.1	
60.0	4.1	4.3	4.4		
掛数	1	1	1	1	1
危険角度 (°)	10	20	30	45	60
フック種類	12t	12t	12t	12t	12t
フック質量 (t)	0.53	0.53	0.53	0.53	0.53

HD性能

22.7mブーム+4.4m+47mヘビーリフトジブ

オフセット	10°	20°	30°	45°	60°
作業半径 (m)	荷重 (ton)	荷重 (ton)	荷重 (ton)	荷重 (ton)	荷重 (ton)
20.0	12.0				
22.0	12.0				
24.0	12.0				
26.0	12.0				
28.0	12.0	12.0			
30.0	12.0	12.0			
32.0	12.0	12.0			
34.0	10.8	12.0	12.0		
36.0	9.7	10.9	12.0		
38.0	8.7	9.8	10.9		
40.0	7.8	8.8	9.8		
42.0	7.0	7.9	8.9	8.9	
44.0	6.2	7.1	8.0	8.6	
46.0	5.6	6.4	7.2	8.2	
48.0	5.0	5.7	6.5	7.6	7.1
50.0	4.4	5.1	5.8	6.8	6.9
55.0	2.9	3.8	4.4	5.1	5.7
60.0	1.6	2.3	2.9	3.6	
65.0			1.4		
掛数	1	1	1	1	1
危険角度 (°)	34	36	36	45	60
フック種類	12t	12t	12t	12t	12t
フック質量 (t)	0.53	0.53	0.53	0.53	0.53

HD性能

18.15mブーム+4.4m+47mヘビーリフトジブ

オフセット	10°	20°	30°	45°	60°
作業半径 (m)	荷重 (ton)	荷重 (ton)	荷重 (ton)	荷重 (ton)	荷重 (ton)
20.0	12.0				
22.0	12.0				
24.0	12.0				
26.0	12.0	12.0			
28.0	12.0	12.0			
30.0	12.0	12.0			
32.0	12.0	12.0			
34.0	11.7	12.0	12.0		
36.0	10.5	11.5	12.0		
38.0	9.5	10.5	11.3		
40.0	8.6	9.5	10.3		
42.0	7.8	8.6	9.4	8.8	
44.0	7.1	7.8	8.6	8.4	
46.0	6.5	7.1	7.8	8.0	
48.0	5.9	6.5	7.1	7.7	7.0
50.0	5.3	5.9	6.4	7.2	6.8
55.0	4.1	4.6	5.0	5.6	6.0
60.0	2.9	3.4	3.7	4.1	
65.0	1.8	2.0			
掛数	1	1	1	1	1
危険角度 (°)	11	20	30	45	60
フック種類	12t	12t	12t	12t	12t
フック質量 (t)	0.53	0.53	0.53	0.53	0.53

HD性能

31.8mブーム+4.4m+47mヘビーリフトジブ

オフセット	10°	20°	30°	45°	60°
作業半径 (m)	荷重 (ton)	荷重 (ton)	荷重 (ton)	荷重 (ton)	荷重 (ton)
22.0	12.0				
24.0	12.0				
26.0	12.0				
28.0	12.0				
30.0	12.0	12.0			
32.0	11.5	12.0			
34.0	10.2	11.7			
36.0	9.1	10.4	11.8		
38.0	8.0	9.3	10.6		
40.0	7.1	8.3	9.5		
42.0	6.3	7.4	8.5		
44.0	5.6	6.6	7.6	8.8	
46.0	4.9	5.9	6.8	8.2	
48.0	4.3	5.2	6.1	7.4	
50.0	3.6	4.6	5.4	6.6	7.0
55.0	2.0	3.0	4.0	4.9	5.6
60.0		1.5	2.4	3.4	4.0
65.0				1.7	
掛数	1	1	1	1	1
危険角度 (°)	48	50	51	51	60
フック種類	12t	12t	12t	12t	12t
フック質量 (t)	0.53	0.53	0.53	0.53	0.53

HD性能

40.9mブーム+4.4m+47mヘビーリフトジブ

オフセット	10°	20°	30°	45°	60°
作業半径 (m)	荷重 (ton)	荷重 (ton)	荷重 (ton)	荷重 (ton)	荷重 (ton)
26.0	8.0				
28.0	8.0				
30.0	8.0				
32.0	8.0	8.0			
34.0	8.0	8.0			
36.0	8.0	8.0			
38.0	7.5	8.0			
40.0	6.6	7.9	8.0		
42.0	5.8	7.0	8.0		
44.0	5.1	6.2	7.3		
46.0	4.3	5.5	6.5		
48.0	3.5	4.8	5.8	7.2	
50.0	2.8	4.2	5.1	6.4	
55.0			3.6	4.7	5.6
60.0				3.2	3.9
65.0					2.1
掛数	1	1	1	1	1
危険角度 (°)	59	60	61	61	61
フック種類	12t	12t	12t	12t	12t
フック質量 (t)	0.53	0.53	0.53	0.53	0.53

HD性能

50.0mブーム+4.4m+47mヘビーリフトジブ

オフセット	10°	20°	30°	45°	60°
作業半径 (m)	荷重 (ton)	荷重 (ton)	荷重 (ton)	荷重 (ton)	荷重 (ton)
26.0	5.0				
28.0	5.0				
30.0	5.0				
32.0	5.0				
34.0	5.0	5.0			
36.0	5.0	5.0			
38.0	5.0	5.0			
40.0	5.0	5.0	4.5		
42.0	5.0	5.0	4.4		
44.0		5.0	4.3		
46.0		4.9	4.2		
48.0		4.5	4.1	3.1	
50.0			4.0	3.0	
55.0				2.9	2.0
60.0					2.0
掛数	1	1	1	1	1
危険角度 (°)	66	67	67	68	68
フック種類	12t	12t	12t	12t	12t
フック質量 (t)	0.53	0.53	0.53	0.53	0.53

HD性能

45.5mブーム+4.4m+47mヘビーリフトジブ

オフセット	10°	20°	30°	45°	60°
作業半径 (m)	荷重 (ton)	荷重 (ton)	荷重 (ton)	荷重 (ton)	荷重 (ton)
26.0	7.5				
28.0	7.5				
30.0	7.5				
32.0	7.5				
34.0	7.5	7.5			
36.0	7.5	7.5			
38.0	7.3	7.5			
40.0	6.4	7.5	7.5		
42.0	5.5	6.8	7.5		
44.0	4.8	6.0	7.2		
46.0	3.9	5.3	6.4		
48.0		4.6	5.7	6.7	
50.0		3.9	5.0	6.3	
55.0			3.3	4.6	4.9
60.0				3.1	3.9
掛数	1	1	1	1	1
危険角度 (°)	63	64	65	65	65
フック種類	12t	12t	12t	12t	12t
フック質量 (t)	0.53	0.53	0.53	0.53	0.53

HD性能

13.6mブーム+4.4m+54mヘビーリフトジブ

オフセット	10°	20°	30°	45°	60°
作業半径 (m)	荷重 (ton)	荷重 (ton)	荷重 (ton)	荷重 (ton)	荷重 (ton)
22.0	9.3				
24.0	9.3				
26.0	9.3				
28.0	9.3				
30.0	9.1	8.9			
32.0	9.1	8.8			
34.0	9.0	8.8			
36.0	8.9	8.6			
38.0	8.7	8.2	7.7		
40.0	8.4	7.9	7.4		
42.0	8.0	7.6	7.2		
44.0	7.7	7.3	6.9		
46.0	7.4	7.0	6.7	6.2	
48.0	7.0	6.8	6.5	6.1	
50.0	6.5	6.6	6.3	5.9	
55.0	5.3	5.7	5.9	5.4	4.9
60.0	4.3	4.6	4.9	4.9	4.6
65.0	3.5	3.7	3.9		
掛数	1	1	1	1	1
危険角度 (°)	10	20	30	45	60
フック種類	12t	12t	12t	12t	12t
フック質量 (t)	0.53	0.53	0.53	0.53	0.53

HD性能

22.7mブーム+4.4m+54mヘビーリフトジブ

オフセット	10°	20°	30°	45°	60°
作業半径 (m)	荷重 (ton)	荷重 (ton)	荷重 (ton)	荷重 (ton)	荷重 (ton)
24.0	9.3				
26.0	9.3				
28.0	9.3				
30.0	9.1				
32.0	9.1	8.9			
34.0	9.1	8.8			
36.0	9.0	8.7			
38.0	8.9	8.6	7.9		
40.0	8.1	8.3	7.7		
42.0	7.3	8.0	7.4		
44.0	6.6	7.6	7.2		
46.0	5.9	6.9	7.0		
48.0	5.3	6.2	6.8	6.2	
50.0	4.8	5.6	6.4	6.0	
55.0	3.4	4.2	4.9	5.7	5.1
60.0	2.1	2.9	3.7	4.5	4.8
65.0		1.7	2.3	3.2	3.6
70.0				1.5	
掛数	1	1	1	1	1
危険角度 (°)	40	42	43	45	60
フック種類	12t	12t	12t	12t	12t
フック質量 (t)	0.53	0.53	0.53	0.53	0.53

HD性能

18.15mブーム+4.4m+54mヘビーリフトジブ

オフセット	10°	20°	30°	45°	60°
作業半径 (m)	荷重 (ton)	荷重 (ton)	荷重 (ton)	荷重 (ton)	荷重 (ton)
22.0	9.3				
24.0	9.3				
26.0	9.3				
28.0	9.3				
30.0	9.1	9.0			
32.0	9.1	9.0			
34.0	9.1	8.9			
36.0	8.9	8.8			
38.0	8.8	8.4	7.8		
40.0	8.7	8.1	7.6		
42.0	8.1	7.8	7.3		
44.0	7.4	7.5	7.1		
46.0	6.7	7.3	6.8		
48.0	6.1	6.8	6.6	6.1	
50.0	5.6	6.2	6.4	6.0	
55.0	4.4	4.9	5.5	5.5	5.0
60.0	3.3	3.8	4.3	4.9	4.7
65.0	2.2	2.7	3.2	3.7	
70.0		1.6	1.9		
掛数	1	1	1	1	1
危険角度 (°)	20	20	30	45	60
フック種類	12t	12t	12t	12t	12t
フック質量 (t)	0.53	0.53	0.53	0.53	0.53

HD性能

31.8mブーム+4.4m+54mヘビーリフトジブ

オフセット	10°	20°	30°	45°	60°
作業半径 (m)	荷重 (ton)	荷重 (ton)	荷重 (ton)	荷重 (ton)	荷重 (ton)
26.0	9.0				
28.0	9.0				
30.0	9.0				
32.0	9.0	8.9			
34.0	9.0	8.8			
36.0	9.0	8.7			
38.0	8.4	8.7			
40.0	7.5	8.7	7.9		
42.0	6.7	7.9	7.6		
44.0	5.9	7.1	7.4		
46.0	5.3	6.4	7.2		
48.0	4.7	5.7	6.7		
50.0	4.0	5.1	6.0	6.1	
55.0	2.4	3.7	4.5	5.7	
60.0		2.2	3.2	4.3	4.9
65.0			1.8	2.9	3.6
70.0				1.4	
掛数	1	1	1	1	1
危険角度 (°)	53	54	55	55	60
フック種類	12t	12t	12t	12t	12t
フック質量 (t)	0.53	0.53	0.53	0.53	0.53

HD性能

40.9mブーム+4.4m+54mヘビーリフトジブ

オフセット	10°	20°	30°	45°	60°
作業半径 (m)	荷重 (ton)	荷重 (ton)	荷重 (ton)	荷重 (ton)	荷重 (ton)
28.0	6.0				
30.0	6.0				
32.0	6.0				
34.0	6.0				
36.0	6.0	6.0			
38.0	6.0	6.0			
40.0	6.0	6.0			
42.0	6.0	6.0			
44.0	5.4	6.0	6.0		
46.0	4.7	6.0	6.0		
48.0	4.0	5.3	6.0		
50.0	3.2	4.7	5.7		
55.0		3.0	4.2	5.5	
60.0			2.7	4.1	4.9
65.0				2.6	3.5
掛数	1	1	1	1	1
危険角度 (°)	62	63	64	65	65
フック種類	12t	12t	12t	12t	12t
フック質量 (t)	0.53	0.53	0.53	0.53	0.53

HD性能

50.0mブーム+4.4m+54mヘビーリフトジブ

オフセット	10°	20°	30°	45°	60°
作業半径 (m)	荷重 (ton)	荷重 (ton)	荷重 (ton)	荷重 (ton)	荷重 (ton)
30.0	4.1				
32.0	4.1				
34.0	4.1				
36.0	4.1				
38.0	4.1	4.1			
40.0	4.1	4.1			
42.0	4.1	4.1			
44.0	4.1	4.0			
46.0		3.9	3.2		
48.0		3.8	3.1		
50.0		3.7	3.0		
55.0			2.8	2.0	
60.0				1.9	
掛数	1	1	1	1	1
危険角度 (°)	68	69	70	71	71
フック種類	12t	12t	12t	12t	12t
フック質量 (t)	0.53	0.53	0.53	0.53	0.53

HD性能

45.5mブーム+4.4m+54mヘビーリフトジブ

オフセット	10°	20°	30°	45°	60°
作業半径 (m)	荷重 (ton)	荷重 (ton)	荷重 (ton)	荷重 (ton)	荷重 (ton)
28.0	5.5				
30.0	5.5				
32.0	5.5				
34.0	5.5				
36.0	5.5	5.5			
38.0	5.5	5.5			
40.0	5.5	5.5			
42.0	5.5	5.5			
44.0	5.2	5.5	5.5		
46.0	4.4	5.5	5.5		
48.0		5.1	5.5		
50.0		4.5	5.5		
55.0			4.1	5.2	
60.0				4.0	3.7
65.0					3.5
掛数	1	1	1	1	1
危険角度 (°)	65	67	68	69	69
フック種類	12t	12t	12t	12t	12t
フック質量 (t)	0.53	0.53	0.53	0.53	0.53